

WEST KERN COMMUNITY COLLEGE DISTRICT  
AGENDA FOR REGULAR MEETING

October 10, 2018

**Cougar Room**  
(Access Through the Library Entrance)

5:00 p.m.

29 Cougar Court  
Taft, California 93268

**A. Accessibility.** In compliance with the Americans with Disabilities Act, if you need special assistance to access the meeting room or to otherwise participate in this meeting, including auxiliary aids or services, please contact Sarah Criss at (661) 763-7711. Notification at least 48 hours prior to the meeting will enable the Governing Board to make reasonable arrangements to ensure accessibility to the meeting.

**B. Obtaining Public Records.** A copy of the Board packet, including documents relating to any open session item are available to members of the public on the District website and also at the District Office. Any writings or documents that are public records and are provided to a majority of the Governing Board regarding an open session item on this agenda will be made available for public inspection in the District Office located at 29 Cougar Ct., Taft, California, during normal business hours. These documents will be made available to the public at the same time that they are made available to a majority of the Board.

**C. Language Assistance.** The District welcomes Spanish and other language speakers to Board meetings. Anyone planning to attend and needing an interpreter should call Sarah Criss at (661) 763-7711 forty-eight (48) hours in advance of the meeting so that arrangements can be made for an interpreter. El Distrito da la bienvenida a las personas de habla hispana a las juntas de la Mesa Directiva. Si planea asistir y necesita interpretacion llame al (661) 763-7711 (48) horas antes de la junta, para poder hacer arreglos de interpretacion.

**D. Addressing the District Board.** The Board encourages public participation and involvement. Community members will therefore have several opportunities to address the Board. However, please respect the Board's time and the need for efficient board meetings. The Board also requests that comments be respectful and professional.

1. **Agenda Items.** If you wish to address the Board on an agenda item, please do so when that item is called. Presentations will be limited to a maximum of three (3) minutes. Time limitations are at the discretion of the Board President.
2. **Non-Agenda Items.** Individuals have an opportunity to address the Board during the period set aside for Public Comment on Items of General Interest on topics within the subject matter jurisdiction of the Board **not** listed on the agenda. Presentations will be limited to a maximum of three (3) minutes, with a total of thirty (30) minutes designated for this portion of the agenda.

**E. Questions for the Board.** Individuals with questions on District issues may submit them in writing. The Board will refer such requests to the Superintendent, who will endeavor to respond to your questions after the meeting.

**F. Placing issues on the Board Agenda.** Items from the public pertaining directly to College business may be placed on the Board agenda by submitting the request in writing to the Office of the Superintendent. The proposed agenda item will be reviewed and placed, if appropriate, on the Board's agenda within a reasonable period of time. Please contact the Office of the Superintendent at (661) 763-7711 for further information.

Tour of Child Development Center at 4:00 p.m. (729 Ash Street, Taft, CA 93268)

1. CALL TO ORDER
2. PUBLIC COMMENT ON CLOSED SESSION ITEMS

3. ADJOURN TO CLOSED SESSION
  - A. Public Employee Appointment/Employment, Government Code Section 54957
  - B. Public Employee Performance Evaluations, Government Code Section 54957
  - C. Public Employee Discipline/Dismissal/Release/Complaint, Government Code Section 54957
  - D. Conference with Labor Negotiators (Government Code section 54957.6)  
Agency Designated Representative: Superintendent/President  
Employee Organizations: TC Faculty Association, CSEA Chapter #543 & Management/Supervisory/Classified Confidential Employees
  - E. Conference with Legal Counsel - Anticipated Litigation  
Significant Exposure to Litigation Pursuant to Paragraph (2) or (3) of Subdivision (d) of Section 54956.9 - 2 Potential Cases  
Claim Received from Donald Thornsberry  
Claim Received from Melissa Thornsberry
  - F. Conference with Legal Counsel - Anticipated Litigation  
Significant Exposure to Litigation Pursuant to Paragraph (2) or (3) of Subdivision (d) of Section 54956.9 - 1 Potential Case
  - G. Student Discipline and Other Confidential Student Matters, Education Code Sections 35146, 48900 et. Seq. and 48912(b) (2 Cases)
4. RECONVENE IN OPEN SESSION; ANNOUNCE CLOSED SESSION ACTIONS
5. PLEDGE OF ALLEGIANCE
6. PUBLIC COMMENT ON OPEN SESSION AGENDA ITEMS
7. GENERAL COMMUNICATIONS
8. PRESENTATION - AB 705
9. APPROVAL OF MINUTES - Regular Meeting Held September 12, 2018 and Special Meeting Held September 12, 2018
10. NEW BUSINESS:
  - A. Request for Approval - Renaming of Library Math Lab in Honor of Synagro
  - B. Request for Approval - Accrediting Commission for Community and Junior Colleges - Midterm Report (Presentation)
  - C. Second Presentation and Request for Approval - Agreement Between CSEA Chapter #543 and the West Kern Community College District - Proposed Compensation Increase of 2.71% COLA to the 2018-19 Classified Salary Schedules, Appendix A; Retroactive to 7/1/18

- D. Second Presentation and Request for Approval – Agreement with Taft College Faculty Association (TCFA/CTA/NEA) and West Kern Community College District – Proposed Compensation Increase of 2.71% COLA to the 2018-19 Faculty Salary Schedules, Appendix B-1, B-2 and B-3; Retroactive to 7/1/18
- E. Request for Approval – Proposed Compensation Increase of 2.71% COLA to the Management and Confidential 2018-19 Salary Schedules; Retroactive to 7/1/18
- F. Request for Approval – Proposed Compensation Increase of 2.71% COLA to the Superintendent/President 2018/19 Salary Schedule; Retroactive to 7/1/18
- G. Request for Approval – Request for Approval to Proceed with Gym Storage Building Replacement Project with Iron Nikkel Construction; \$37,900.00
- H. Request for Approval – Request for Approval to Proceed with the G Buildings Door Hardware Phase Two Project with Converjint Technologies, \$35,912.78
- I. Request for Approval – Request for Approval to Proceed with the 2018-19 Deferred Maintenance Energy Management System Controller Replacement Project with Alcorn Aire, \$16,875.00

11. CONSENT AGENDA (Items A – M)

- A. Request for Approval – Course Inactivations

Applied Technologies Division

- IES 1050 Hazardous Materials
- IES 1052 Respiratory Protection
- IES 1053 Principles of Ergonomics
- IES 1054 Permit Required Confined Space
- IES 1058 Occupational Safety and Health Standards for the Construction Industry
- IES 1059 Trainer Course in Occupational Safety and Health Standards for the Construction Industry
- IES 1061 Occupational Safety and Health for General Industry

- B. Request for Approval – Course Revisions

Applied Technologies Division

- BUSN 2900 Business Capstone
- IES 1500 Occupational Safety and Health Compliance
- IES 1532 Industrial Hygiene
- IES 2000 Occupational Safety and Health Capstone
- IES 2065 Trainer Course in Occupational Safety and Health Standards

Math and Science Division

MATH 1540 Precalculus Mathematics  
PHYS 2221 General Physics  
STAT 1510 Elementary Statistics

Liberal Arts Division

PHIL 1501 Introduction to Philosophy

C. Request for Approval - New Courses

Learning Support Division

STSU 1525 Transfer Planning  
STSU 1550 Funding a Transfer Plan

Math & Science Division

MATH 1510 College Algebra for Liberal Arts

Social Science Division

EDUC 1520 Introduction to Elementary Education for the Contemporary

D. Request for Approval - Program Revision

Math & Science Division

Liberal Arts Area of Emphasis: Math and Science

- E. Request for Ratification - Amendment 01 to the Resolution Authorizing Agreement with the California Department of Education Migrant Specialized Services Program; 7/1/18 - 6/30/19; New MRA is \$98,159.00 (Increase of \$7,665.00)
- F. Request for Ratification - Amendment 01 to the Resolution Authorizing Agreement with the California Department of Education Migrant Child Care Program; 7/1/18 - 6/30/19; New MRA is \$706,722.00 (Increase of \$98,332.00)
- G. Request for Ratification - Agreement with Strata Information Services Quote for IT Programming Support, \$170.00 per Hour (May Annually Increase \$5.00 per Hour per Agreement), Total Cost Estimated \$30,600.00 - \$40,800.00
- H. Request for Ratification - Independent Contractor Agreement with Jamie Smith, The Internal Potential, for Evaluation of the Child Care Center, 7/1/18 -8/30/18, \$120.00 per Hour and Travel Expenses (Total Payment Not to Exceed \$14,400.00)
- I. Request for Ratification - Agreement with BSK Associates in Connection with Scoreboard Replacement; \$5,441.00

- J. Request for Ratification – Renewal of PrestoSports for Web Design/Hosting Services, 9/1/18 – 8/31/21, Estimated Cost for 2018-19 is \$3,350.00 with the Total 3 Year Cost Expected to be \$10,350.00
- K. Request for Approval – Professional Services Agreement with Trudi Ratke in Association with the Zero Textbook Cost Grant, 10/15-18 – 1/15/19, \$1,500.00
- L. Request for Approval – Renewal of Eureka Agency/User Site License Contract, 1/1/19 – 12/31/19, \$1,496.14
- M. Ratification of the September 2018 Vendor Check & Purchase Order Registers

12. PUBLIC COMMENT ON ITEMS OF GENERAL INTEREST

13. EMPLOYMENT

- A. Academic Employment (Appendix I)
- B. Classified Employment (Appendix II)
- C. Resignation/Retirements (Appendix II)

14. REPORTS:

- A. Financial Reports (for information):
  - 1. Revenue Accounts (Account Level 1) FY 2018/19
  - 2. Expenditure Accounts (Account Level 1) FY 2018/19
  - 3. Expenditure Detail of \$10,000.00 or Greater, September 2018
  - 4. Student Organization and Special Accounts, September 2018
  - 5. Funds Deposited in County Treasury, September 2018
- B. Trustee Reports
- C. Academic Senate Report
- D. Reports from Staff and Student Organizations

15. REPORT OF THE SUPERINTENDENT

16. NEXT MEETING DATE

The next regular meeting is scheduled for Wednesday, November 14, 2018, at 5:00 p.m.

17. CONTINUATION OF CLOSED SESSION (If Necessary)

18. ADJOURNMENT

**WEST KERN COMMUNITY COLLEGE DISTRICT  
MINUTES OF THE BOARD OF TRUSTEES**

**REGULAR MEETING**

**September 12, 2018**

The regular meeting of the Board of Trustees of the West Kern Community College District was called to order at 5:00 p.m. by President Dawn Cole. Secretary Emmanuel Campos and trustees Dr. Kathy Orrin and Billy White were present. Trustee Michael Long was absent. Superintendent/President Dr. Debra Daniels and Executive Secretary Sarah Criss were in attendance.

**PUBLIC COMMENT ON CLOSED SESSION ITEMS**

No comments were heard.

**CLOSED SESSION**

At 5:01 p.m. it was moved by Trustee White, seconded by Trustee Orrin and unanimously carried, that the Board convene in Closed Session to discuss the District's position regarding the following matters:

- A. Public Employee Appointment/Employment, Government Code Section 54957
- B. Public Employee Performance Evaluations, Government Code Section 54957
- C. Public Employee Discipline/Dismissal/Release/Reassignment, Government Code Section 54957
- D. Conference with Labor Negotiators (Government Code section 54957.6)  
Agency Designated Representative: Superintendent/President  
Employee Organizations: TC Faculty Association, CSEA Chapter #543 & Management/Supervisory/Classified Confidential Employees
- E. Conference with Legal Counsel - Anticipated Litigation  
Significant Exposure to Litigation Pursuant to Paragraph (2) or (3) of Subdivision (d) of Section 54956.9 - 2 Potential Cases  
Claim Received from Donald Thornsberry  
Claim Received from Melissa Thornsberry
- F. Conference with Legal Counsel - Anticipated Litigation  
Significant Exposure to Litigation Pursuant to Paragraph (2) or (3) of Subdivision (d) of Section 54956.9 - 1 Potential Case
- G. Student Discipline and Other Confidential Student Matters, Education Code Sections 35146, 48900 et. Seq. and 48912(b)

**RECONVENE IN PUBLIC SESSION; ANNOUNCE CLOSED SESSION ACTIONS**

At 6:01 p.m., it was moved by Trustee Orrin, seconded by Secretary Campos and unanimously carried, to reconvene in Public Session. President Cole reported there was no action taken during Closed Session.

**PLEDGE OF ALLEGIANCE**

President Cole led the pledge of allegiance.

**PUBLIC COMMENT ON OPEN SESSION ITEMS**

No comments were heard.

**GENERAL COMMUNICATIONS**

Severo Balason, Jr., Vice President of Student Services, introduced the Dean of Student Success, Dr. Windy Martinez.

**PRESENTATION - Distance Education**

This item was tabled for presenter preparation.

**APPROVAL OF MINUTES**

On a motion by Trustee Orrin, seconded by Trustee White and unanimously carried, the minutes of the Regular Meeting held August 8, 2018 were approved.

**NEW BUSINESS**

**Public Hearing for 2018/19 WKCCD Budget**

President Cole declared the public hearing open at 6:04 p.m. There were no comments made by the public. The hearing was closed at 6:05 p.m.

**Request for Approval - 2018/19 WKCCD Budget**

Brock McMurray, Executive Vice President of Administrative Services, noted that the budget (as presented at the special meeting prior to the regular meeting) was completed with many staff efforts made across the campus. President Cole also noted appreciation of staff in connection with the budget preparation. On a motion by Trustee White, seconded by Secretary Campos and unanimously carried, the budget was approved.

**Request for Approval - Delegation of Authority to the Superintendent/President to Enter Into Takeover Agreement with Allied World Insurance Company Re: Student Center Project**

Mr. McMurray told the Board that the District is requesting the resolution giving the Superintendent/President the authority to enter into an agreement on the Student Center Project to avoid running into possible time constraints (copy attached to official minutes). On a motion by Secretary Campos and seconded by Trustee Orrin, the resolution was approved by the following vote:

Yes: Dawn Cole, Emmanuel Campos, Dr. Kathy Orrin and Billy White

No: None

Abstain: None

Absent: Michael Long

**Request for Approval - Recommendation to Award Black/Hall Construction the S-4 Fume Hood Project, \$141,161.00**

Dr. Daniels told the Board that the installing of fume hoods to convert the classroom to a laboratory classroom will assist in serving the needs of students. On a motion by Secretary Campos, seconded by Trustee White and unanimously carried, the request was approved (copy attached to official minutes).

**First Presentation - Agreement Between CSEA Chapter #543 and the West Kern Community College District - Proposed Compensation Increase of 2.71% COLA to the 2018-19 Classified Salary Schedules, Appendix A; Retroactive to 7/1/18**

Dr. Daniels reported that the cost of living allowance (COLA) from the state was approved at 2.71%. The District would like to pass the COLA to the compensation of classified employees. The attached agreement has gone through the negotiation process and the terms have been agreed upon (copy attached to official minutes).

**First Presentation - Agreement with Taft College Faculty Association (TCFA/CTA/NEA) and West Kern Community College District - Proposed Compensation Increase of 2.71% COLA to the 2018-19 Faculty Salary Schedules, Appendix B-1, B-2 and B-3; Retroactive to 7/1/18**

Dr. Daniels reported that the cost of living allowance (COLA) from the state was approved at 2.71%. Similarly to the classified unit, the District would like to pass the approved COLA to the compensation of faculty. The attached agreement has gone through the negotiation process the terms have been agreed upon (copy attached to official minutes).

**Request for Approval - West Kern Community College District Equal Employment Opportunity Plan 2018-2021**

Dr. Daniels explained that the District is required to update the Equal Employment Opportunity plan every three years. Through the work of Human Resources and the Equal Employment Opportunity committee, the current update brings the District to compliance. On a motion by Trustee White, seconded by Secretary Campos and unanimously carried, the plan was approved (copy attached to official minutes).

**CONSENT AGENDA:**

- A. Information Item - Use of Proposition 55 Education Protection Account (EPA) Funds for FY 2018/19
- B. Request for Ratification - Agreement with California Virtual Campus - Online Education Initiative Consortium, Effective Upon Signature



- C. Request for Approval - MOU with Management & Training Corporation for Inmate Education Services at the Taft Correctional Institute, Effective Upon Signature for a Period of Three Calendar Years Thereafter
- D. Request for Approval - MOU with Taft Modified Community Correction Facility (TMCCF) for Inmate Education Services, Effective Upon Signature for a Period of Three Calendar Years Thereafter
- E. Request for Ratification - Agreement with the Yosemite Community College District, Child Development Training Consortium (YCCD/CDTC), 9/1/18 - 6/30/19, CDTC will Pay Becky Roth \$7,500.00
- F. Request for Approval - CampusLogic Subscription Order, 10/1/18 - 9/20/21, \$27,000 Per Year with a One-Time Implementation Fee of \$3,500.00 (Total 3-Year Cost \$84,500.00)
- G. Request for Approval - Contract with Strata Information Group (SIG) for Consulting Services for Financial Aid, Two Weeks (88-96 Hours), Not to Exceed \$19,720.00
- H. Request for Approval - Agreement with Mark Potter of D2UP, LLC as Motivational Speaker, 9/5/18, Flat Fee of \$2,250.00
- I. Request for Approval - Agreement with E-Colors in Education for Workshop, 1 Day of Training, \$1,539.96 (Which Includes Travel Expenses)
- J. Request for Approval - Agreement with MatchWare for Mindview Software, Effective Upon Purchase for 5 Years, \$4,000.00 Per Year
- K. Request for Ratification - Facilities Use Agreement with West Side Recreation and Parks District for TIL, 8/20/18 - 12/12/18, \$3,000.00
- L. Request for Approval - IssueTrak: One Year of IssueTrak Software Maintenance, October 2018 - October 2019, \$1,725.00
- M. Request for Approval - Equitrac Equipment Support Renewal and On-Site Support - C.A. Reding, 11/1/18 - 10/31/19, \$1,286.60 Annually
- N. Request for Ratification - Consultant Agreement with Sherrie Freitas for Child Care Center, 8/22/18 - 8/23/18, \$28.00 Per Hour, Up to \$400.00 for Mileage/Expenses/Hotel
- O. Ratification of the August 2018 Vendor Check & Purchase Order Registers

On a motion by Trustee Orrin, seconded by Secretary Campos and unanimously carried, Consent Agenda Items A - O were approved as presented (materials related to items A - O are attached to official minutes).

## **PRESENTATION – Distance Education**

Nicole Avina, Integrated Technology Support Technician, presented an update on the Distance Education (DE) department (copy attached to official minutes). Currently, seventy percent of students take at least one DE course. The department serves the technical and academic needs of students. There is a variety of students served, from full time students, part time students, inmates at institutions, and many other different types of students. The DE department also assists the campus with other needs (i.e. filming for classroom projects). While trends for online courses are on the rise, the Taft College DE department is working with the Online Education Initiative consortium to meet the needs of students and expectations from the State level.

## **PUBLIC COMMENTS ON ITEMS OF GENERAL INTEREST**

There were no comments on items of general interest.

## **EMPLOYMENT**

On a motion by Trustee White and seconded by Secretary Campos, Employment Items A – D were approved by the following vote (Employment Items A – D (*Appendix I & II*) are attached to official minutes):

Yes: Dawn Cole, Emmanuel Campos, Dr. Kathy Orrin and Billy White  
No: None  
Abstain: None  
Absent: Michael Long

## **REPORTS**

### **Financial Reports**

The financial reports listed on the page following were presented for information (copies attached to official minutes).

Financial Reports (for information):

1. Revenue Accounts (Account Level 1) FY 2018/19
2. Expenditure Accounts (Account Level 1) FY 2018/19
3. Expenditure Detail of \$10,000.00 or Greater, August 2018
4. Student Organization and Special Accounts, August 2018
5. Funds Deposited in County Treasury, August 2018

### **Academic Senate**

Dr. Vicki Jacobi, Vice President of Academic Senate (AS), reported that that the AS recently recommended that the College apply for the California Academic Partnership Program (CAPP) Capacity Building Grant; the College was awarded the grant. The AS also recommended that the Curriculum and General Education Committee should assist in the update of BP 4020 and AP 4020 in

regards to necessary changes to the credit hour policy. Discussion also focused on AB 705, Guided Pathways, the Online Education Initiative, the Accreditation midterm report as well as the new student centered funding formula.

### **Business Services**

Amanda Bauer, Director of Fiscal Services, reported that the department is in the process of closing the 2017-18 fiscal year.

### **CSEA Chapter #543**

Greg Hawkins, President of the California School Employee Association (CSEA), Chapter #543, introduced Vice President Jeanene Robertson and stewards/representatives Nicole Avina and Morgan Sanchez. Mr. Hawkins and Ms. Robertson both stated Chapter #543 is increasing in participation and that they are looking forward to a great year.

### **Instruction and Career Technical Education**

Jessica Grimes, Interim Dean of Instruction and CTE, told the Board she has had many meetings and staff are currently focused on curriculum alignment, providing innovative options with the inmate population, increasing student retention and continued connections with community.

### **Human Resources**

Heather Meason, Executive Director of Human Resources, said that the department is still reviewing and updating processes and procedures. The District recruitment efforts are ongoing. Ms. Meason also noted that the department is utilizing the Chancellor's resources for many free lessons for software applications used in most college offices.

### **Taft College Faculty Association**

Diane Jones, President of the Faculty Association, thanked the Human Resource department for their involvement in securing on an on-campus flu shot clinic for the employees and dependents of employees. She also thanked the Distance Education staff for their assistance to the faculty while the District fills the open position of Distance Education coordinator.

### **Campus Security & Safety**

Kevin Altenhofel, Director of Campus Safety, reported that cameras have been installed at the College bookstore. Efforts will be made to increase security at that location.

### **Information Services**

Andrew Prestage, Executive Director of Information Services, gave the Board a brief update of projects completed by the department in preparation for the start of the semester. There have been phishing attempts on campus and the department is also educating campus users on power consumption during non-business hours. The District is in the process of implementing a single sign on (SSO) for many of the College's applications. Staff have worked to purchase necessary audio-visual equipment for some classrooms and are working to install the equipment. During the transition to Banner 9 this semester, the department is holding weekly sessions for users to become accustomed to the new interface.

**Transition to Independent Living**

Aaron Markovits, Executive Director of TIL, said that the students are adjusting to life on campus and to having rigorous schedules. Students have also begun jobs. Currently, staff have been continuing efforts to acclimatize students by hosting athlete and TIL student events. The events have been successful and are building confidence in the TIL students among their peers. Dr. Jacobi added that the TIL students are participating in survey/data collection to increase efforts to integrate future TIL students into other College courses (non-TIL courses). The goal is to develop possible pathways for TIL students.

**Student Success**

Dr. Windy Martinez, Dean of Student Success, stated she is looking forward to working with the talent on campus. Dr. Martinez noted that this staff has been extremely accessible during her transition.

**Student Services**

Severo Balason, Jr., Vice President of Student Services, noted the College selection for the grant for the CAPP opportunity. He explained this grant is an initial funding resource to compete for a possible \$150,000 grant that would be disbursed over the course of five years.

**REPORT OF THE SUPERINTENDENT**

Dr. Daniels reported that the District's inservice week was busy with professional development opportunities and the annual welcome back breakfast. Enrollment continues to be strong at the College and the current headcount shows a 5% growth from last fall. Dr. Daniels also commended the Men's Soccer team for their current rank of #1 in the state.

**NEXT MEETING**

The next monthly meeting is scheduled for Wednesday, October 10, 2018, at 5:00 p.m.

**CONTINUATION OF CLOSED SESSION**

On a motion by Secretary Campos, seconded by Trustee Orrin and unanimously carried, the Board reconvened into closed session at 7:08 p.m.

**RECONVENE IN PUBLIC SESSION; ANNOUNCE CLOSED SESSION ACTIONS**

At 8:30 p.m., it was moved by Trustee White, seconded by Trustee Orrin and unanimously carried, to reconvene in Public Session. President Cole reported that no action was taken during Closed Session.

**ADJOURNMENT**

At 8:31 p.m., on a motion by Trustee Orrin, seconded by Trustee White and unanimously carried, the meeting was adjourned.

Respectfully Submitted:

---

Emmanuel Campos, Secretary

**WEST KERN COMMUNITY COLLEGE DISTRICT  
MINUTES OF THE BOARD OF TRUSTEES**

**SPECIAL MEETING  
BUDGET STUDY SESSION**

**September 12, 2018**

The special meeting of the Board of Trustees of the West Kern Community College District was called to order at 4:00 p.m. by President Dawn Cole. Secretary Emmanuel Campos and trustees Dr. Kathy Orrin and Billy White were present. Trustee Michael Long was absent. Superintendent/President Dr. Debra Daniels and Executive Secretary Sarah Criss were in attendance.

**PUBLIC COMMENT ON THE 2018/19 PROPOSED BUDGET**

No comments were heard.

**2018/19 BUDGET STUDY SESSION**

Brock McMurray, Executive Vice President of Administrative Services, reviewed points of interest in the 2018/19 proposed WKCCD budget in a PowerPoint presentation (copy attached to official minutes).

**State Budget:**

- \$141.8 billion with a \$15.9 billion reserve
- \$16.7 billion increase from 2017/18

**Impacts to Community Colleges:**

- New Student Centered Funding Formula (SCFF)
  - Base – Enrollments (FTES)
  - Supplemental – Counts of low-income students
  - Student Success – Counts of outcomes related to the *Vision for Success*, with “premiums” for outcomes of low-income students
- \$270 million additional general apportionments
- \$100 million one-time, \$20 million ongoing for online education
- \$50 million ongoing for full-time faculty
- \$50 million one-time for part-time faculty
- \$46 million ongoing to College Promise Program
- \$41 million additional to Cal Grant Program
- CalSTRS up from 14.43% in 2017/18 to 16.3% in 2018/19
- CalPERS up from 15.531% in 2017/18 to 18.1% in 2018/19

**WKCCD Budget:**

- Projection of COLA 2.71%
- Step, Column and Longevity Increases
- Revenue based on AD and Governor’s/Legislature 2018-19 Enacted Budget
- Growth budgeted at 1.52% for 2018-19
- \$617,228 OPEB Obligation

Mr. McMurray reported that the total proposed WKCCD 2018/19 budget is balanced at \$44,979,006. He described the SCFF and the 3-year phase in that will be implemented. Also explained was the blending of the SSSP, Basic Skills, and Equity funds into one Student Equity and Achievement Program allocation in an effort to support Guided Pathways initiatives.

Mr. McMurray thanked the staff involved with the development of the budget as well as the Board for their continued support of the District. President Cole echoed the sentiments to the staff who prepared the budget.

#### **NEXT MEETING**

The next monthly meeting is scheduled for Wednesday, September 12, 2018, at 5:00 p.m.

#### **ADJOURNMENT**

At 4:50 p.m., on a motion by Trustee White, seconded by Secretary Campos and unanimously carried, the meeting was adjourned.

Respectfully Submitted:

---

Emmanuel Campos, Secretary

**Date:** October 4, 2018  
**Submitted by:** Dr. Debra Daniels, Superintendent/President  
**Area Administrator:** Dr. Debra Daniels, Superintendent/President  
**Subject:** Request for Approval

---

**Board Meeting Date:** October 10, 2018

**Title of Board Item:**

Naming of Facility - Taft College Library Math Lab

**Background:**

In honor of corporate sponsor Synagro, I am recommending the approval to rename the Taft College Library Math Lab. Executive Director of Taft College Foundation and Institutional Advancement Sheri Horn-Bunk has submitted the attached request to celebrate the continued support of the College since 2008 with Synagro giving now totaling over \$200,000 in a variety of charitable giving instances.

**Terms (if applicable):**

N/A

**Expense (if applicable):**

N/A

**Fiscal Impact Including Source of Funds (if applicable):**

N/A

**Approved:**   
\_\_\_\_\_  
Dr. Debra Daniels, Superintendent/President





**September 25, 2018**

**Memorandum: Naming of Facilities/WKCCD/Taft College**

To: Dr. Debra Daniels Superintendent/President WKCCD/Taft College

From: Sheri Horn-Bunk Executive Director-Foundation and Institutional Advancement

**Request of Library Lab Naming**

The Taft College Foundation is submitting a formal request for your review for the naming of the Library Math Lab located on the Taft College Campus. The Corporate donor, Synagro has consistently on an annual basis supported programmatic efforts for our students, which includes, Energy Technology, Veterans Center, Engineering, Child Care Center and the Transition to Independent Living Program. Synagro is a STEM Corporate Circle sponsor and the Synagro Logo is on our Mobile STEM Lab. Their total giving since 2008 is over \$200,000 (includes 2018 October gift) and for that reason we request the name of "Synagro" be placed on the Library Math Lab.

**Projects supported by Synagro at Taft College**

- Transition to Independent Living Program
- Taft College Veterans Center
- Taft College Child Care Center
- Engineering and Energy Technology
- Industrial Health and Safety
- Taft College Art Gallery
- Taft College Foundation Petroleum Partners
- STEM Lab Corporate Circle Sponsor
- West Kern Petroleum Summit (and mini-summit)
- Synagro Leader has served on TC Foundation board since 2008

**Date:** September 12, 2018  
**Submitted by:** Dr. Debra Daniels, Superintendent/President  
**Area Administrator:** Dr. Debra Daniels, Superintendent/President  
**Subject:** Request for Approval

---

**Board Meeting Date:** October 10, 2018

**Title of Board Item:**

Accrediting Commission for Community and Junior Colleges – Midterm Report

**Background:**

In June of 2017, the Accrediting Commission for Community and Junior Colleges (ACCJC) determined that Taft College met all required Eligibility Requirements, Accreditation Standards, and Commission policies (collectively referred to as Standards) for full accreditation. As noted in their action letter that confirmed the determination, the College is required to submit a Midterm Report this fall. The Midterm Report is the compiled evidence of work the College has collaboratively completed to meet the Standards. The full report will be available electronically on Monday, October 8<sup>th</sup> (copies are also available).

**Terms (if applicable):**

N/A

**Expense (if applicable):**

N/A

**Fiscal Impact Including Source of Funds (if applicable):**

N/A

**Approved:**   
\_\_\_\_\_  
Dr. Debra Daniels, Superintendent/President

**Date:** September 26, 2018  
**Submitted by:** Heather Meason, Executive Director of Human Resources  
**Area Administrator:** Dr. Debra Daniels, Superintendent/President  
**Subject:** Request for Approval

---

**Board Meeting Date:** October 10, 2018

**Title of Board Item:**

Second Presentation: Proposed compensation increase of 2.71% COLA to the 2018-19 Classified Salary Schedules, Appendix A.

**Background:**

As part of the continuing dialogue through the Taft College Classified Collective Bargaining Committee, the parties have reached a consensus regarding a compensation increase of 2.71% COLA to the Classified Salary Schedules, Appendix A.

**Terms (if applicable):**

An implementation date retroactive to July 1, 2018 is recommended.

**Expense (if applicable):**

See below.

**Fiscal Impact Including Source of Funds (if applicable):**

The amount will be included in the Adopted Budget for 2018-19.

**Approved:**   
\_\_\_\_\_  
Dr. Debra Daniels, Superintendent/President

**Tentative Agreement Between  
California School Employees Association, Chapter #543  
And  
West Kern Community College District**

**COMPENSATION INCREASE OF 2.71% COLA TO THE CLASSIFIED SALARY SCHEDULE**

This tentative agreement ("Agreement") is made by and between the California School Employees Association, Chapter #543 ("CSEA") and the West Kern Community College District ("District") (collectively referenced as the "parties") with respect to the following recitals:

As part of continuing dialogue through the Taft College Classified Collective Bargaining Committee, the parties have reached a consensus regarding a compensation increase of 2.71% COLA to the Classified Salary Schedules, Appendix A.

Now, therefore, CSEA and the District hereby agree as follows:

1. The above recitals are true and correct.
2. A compensation increase of 2.71% COLA will be applied as outlined above and implemented retroactively to July 1, 2018. The parties further agree to update the Classified Salary Schedules, Appendix A of the collective bargaining agreement ("CBA") as appropriate.
3. Except as set forth in this Agreement, all other terms and conditions of the CBA shall remain unchanged.
4. This Agreement will become effective after ratification by the CSEA members and the District's Governing Board.

\_\_\_\_\_  
Dawn Cole, President  
Board of Trustees  
West Kern Community College District

Dated: October \_\_, 2018

  
\_\_\_\_\_  
Greg Hawkins, President  
California School Employees Association  
Chapter #543

Dated: 9-6, 2018

Board Approval:

First Presentation: September 12, 2018  
Second Presentation/Approval: October 10, 2018

**Date:** September 26, 2018

**Submitted by:** Heather Meason, Executive Director of Human Resources

**Area Administrator:** Dr. Debra Daniels, Superintendent/President

**Subject:** Request for Approval

---

**Board Meeting Date:** October 10, 2018

**Title of Board Item:**

Second Presentation: Proposed compensation increase of 2.71% COLA to the 2018-19 Faculty Salary Schedules, Appendix B-1, B-2 and B-3.

**Background:**

As part of the continuing dialogue through the Taft College Faculty Collective Bargaining Committee, the parties have reached a consensus regarding a compensation increase of 2.71% COLA to the Faculty Salary Schedules, Appendix B-1, B-2 and B-3.

**Terms (if applicable):**

An implementation date retroactive to July 1, 2018 is recommended.

**Expense (if applicable):**

See below.

**Fiscal Impact Including Source of Funds (if applicable):**

The amount will be included in the Adopted Budget for 2018-19.

**Approved:**   
\_\_\_\_\_  
Dr. Debra Daniels, Superintendent/President

**Tentative Agreement Between**  
**Taft College Faculty Association (TCFA/CTA/NEA)**  
**And**  
**West Kern Community College District**

**COMPENSATION INCREASE OF 2.71% COLA TO THE FACULTY SCHEDULE**

This tentative agreement (“Agreement”) is made by and between the Taft College Faculty Association (“TCFA/CTA/NEA”) and the West Kern Community College District (“District”) (collectively referenced as the “parties”) with respect to the following recitals:

As part of continuing dialogue through the Taft College Faculty Collective Bargaining Committee, the parties have reached a consensus regarding a compensation increase of 2.71% COLA to the Faculty Salary Schedules, Appendix B-1, B-2 and B-3.

Now, therefore, TCFA/CTA/NEA and the District hereby agree as follows:

1. The above recitals are true and correct.
2. A compensation increase of 2.71% COLA will be applied as outlined above and implemented retroactively to July 1, 2018. The parties further agree to update the Faculty Salary Schedules, Appendix B-1, B-2 and B-3 of the collective bargaining agreement (“CBA”) as appropriate.
3. Except as set forth in this Agreement, all other terms and conditions of the CBA shall remain unchanged.
4. This Agreement will become effective after ratification by the TCFA/CTA/NEA members and the District’s Governing Board.

\_\_\_\_\_  
Dawn Cole, President  
Board of Trustees  
West Kern Community College District

\_\_\_\_\_  
Diane Jones, President  
Taft College Faculty Association/CTA/NEA

Dated: October \_\_\_\_, 2018

Dated: October \_\_\_\_, 2018

Board Approval:

First Presentation: September 12, 2018  
Second Presentation/Approval: October 10, 2018

# BOARD AGENDA ITEM

**Date:** September 26, 2018  
**Submitted by:** Heather Meason, Executive Director of Human Resources  
**Area Administrator:** Dr. Debra Daniels, Superintendent/President  
**Subject:** Request for Approval

---

**Board Meeting Date:** September 10, 2018

**Title of Board Item:**

First Presentation: Proposed compensation increase of 2.71% COLA to the Management and Confidential 2018-19 Salary Schedules.

**Background:**

The District would like to propose a compensation increase of 2.71% COLA to the Management and Confidential 2018-19 Salary Schedules. The Management and Confidential Groups are unrepresented and this is the same Agreement that is being recommended as parts of Agreements negotiated with TCFA/CTA/NEA and CSEA, Chapter #543. The District has an interest in offering the same Agreement across all classifications regardless of representation.

**Terms (if applicable):**

An implementation date retroactive to July 1, 2018 is recommended.

**Expense (if applicable):**

See below.

**Fiscal Impact Including Source of Funds (if applicable):**

The amount will be included in the Adopted Budget for 2018-19.

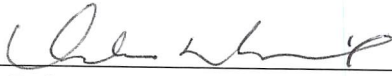
**Approved:**  10/1/18  
Dr. Debra Daniels, Superintendent/President



## BOARD AGENDA ITEM

**Date:** September 28, 2018  
**Submitted by:** Heather Meason, Executive Director of Human Resources  
**Area Administrator:** Dr. Debra Daniels, Superintendent/President  
**Subject:** Request for Approval

---

**Board Meeting Date:** September 10, 2018

**Title of Board Item:**

First Presentation: Proposed compensation increase of 2.71% COLA to the Superintendent/President 2018-19 Salary Schedule.

**Background:**

The District would like to propose a compensation increase of 2.71% COLA to the Superintendent/President 2018-19 Salary Schedule. The Superintendent/President is unrepresented and this is the same Agreement that is being recommended as parts of Agreements negotiated with TCFA/CTA/NEA and CSEA, Chapter #543. The District has an interest in offering the same Agreement across all classifications regardless of representation.

**Terms (if applicable):**

An implementation date retroactive to July 1, 2018 is recommended.

**Expense (if applicable):**

See below.

**Fiscal Impact Including Source of Funds (if applicable):**

The amount will be included in the Adopted Budget for 2018-19.

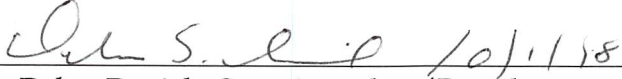
Approved:   
Dr. Debra Daniels, Superintendent/President



**Date:** October 1, 2018  
**Submitted by:** Brock McMurray, EVP of Administrative Services   
**Area Administrator:** Brock McMurray, EVP of Administrative Services  
**Subject:** Request for Approval

---

**Board Meeting Date:** October 10, 2018

**Title of Board Item:**

Request for Approval to Proceed with Gym Storage Building Replacement Project

**Background:**

This is a project to replace the outdoor gym storage building currently used by the Taft College Softball Program. The current outdoor storage building is very old and in need of replacement. Further, it no longer meets the needs of the softball program, athletic department, and kinesiology degree program. Please see the attached project proposal from Iron Nikkel Construction, Inc.

The proposed new gym storage building would allow the athletic department to transfer the contents of the indoor storage room to the new outdoor storage room and still meet the needs of the Softball Program. The indoor storage room would then be used for a biomechanics lab in association with the Kinesiology degree program.

It is my recommendation that Taft College accept Iron Nikkel Construction's project proposal for the new gym storage building and authorize work to begin.

**Terms (if applicable):**

Please see the attached proposal from Iron Nikkel Construction.

**Expense (if applicable):**

\$37,900.00.

**Fiscal Impact Including Source of Funds (if applicable):**

This project will be funded by General Funds allocated for Annual Program Review items.

**Approved:** 

Dr. Debra Daniels, Superintendent/President



## Project Proposal: Taft College New Gym Storage

Prepared for: Taft College

Contact: Mike Capela

Email: [mcapela@taftcollege.edu](mailto:mcapela@taftcollege.edu)

Phone: 661-809-5658

Prepared by: Rob Nikkel

Date: 07/31/18

Proposal number: 07311801

## EXECUTIVE SUMMARY

**Building and Accessories Included:**

20'x40'x11'9"-4" Single Slope Metal Building, 1:12 slope

**Main Frame Type:** Bearing Frame (Single Slope) / **Bay Spacing** (L to R) 2@20'

**LEW Frame Type:** Bearing Frame / **LEW Post Spacing:** 1@20'

**REW Frame Type:** Bearing Frame / **REW Post Spacing:** 1@20'

**X-Braced Bays:** FSW(L to R): 2 / BSW (L to R): 2 / REW (L to R) 0 / LEW (L to R) 0

**Walls:** 26 gage Kynar "R" panel / **Roof:** 26 gage no color (ZA) "R" panel

**Insulation:** None

**Walk Doors:** 2 @ 3'x7', premium series with lever lock.

**Framed Openings:** BSW: 2 @ 10'x8'

**Roll-up Doors:** 2 @ 10'x8', 2000 series with chain hoist (white).

**Windows:** None / **Ridge Vents:** 2

**Skylights:** 2 / **Gutter & Downspouts:** Yes

**Foundation Drawings:** Not Included

Tax, Freight & Off load

**Special Condition:** 20' long x 8' tall partition wall at center line, from high sidewall to low sidewall.

**Building & Accessories** **Price: \$14,500.00**

**Description of Labor:** Fabricate and erect a 20'x40'x11'9"-4" single slope metal building. Demo existing storage building and concrete slab. Pour new 4" concrete slab and footings. Install two roll up doors, two walk doors and 20' partition wall. Iron Nikkel will supply all equipment to off load and erect metal building.

**Labor** **Price: \$23,400.00**

---

**IRON NIKKEL CONSTRUCTION INC.**

**BUDGET**

Description	Quantity	Unit Price	Cost
Building Components and Accessories	1	\$ 14,500	\$ 14,500
Building Erection with new 4" concrete slab	1	\$ 19,400	\$ 19,400
Demo	1	\$ 4,000	\$ 4,000
<b>Total</b>			<b>\$ 37,900</b>

**Detailed Payment Schedule**

Deposit upon order: \$1,000.00  
Due upon Drop: \$13,500.00(Components & Accessories)  
50% Completion: \$ 11,700.00  
Final Completion: \$ 11,700.00

Price excludes permits, permit fees, engineering and anchor bolts. Deposit includes metal building component fees and shipping. Deposit is non refundable. Drop price is due 24 hours before order will be shipped.

Owner/Buyer signature: \_\_\_\_\_ Date: \_\_\_\_\_

Owner/Buyer printed: \_\_\_\_\_ Date: \_\_\_\_\_

**TERMS AND CONDITIONS:** Bid is good for 30 days. Should the owner, lender or inspector make any changes to the plans this contract will be adjusted accordingly. Modifications or additions to the work shall be executed only when a contract change order has been signed by the owner and contractor. Contractor must have access to entire perimeter of described above. All invoices are due upon receipt. If payment is received more than 30 days past the date of invoice, a **5% late fee will be added**. All parts and material will remain in the company name of Iron Nikkel until invoices are paid in full. Contract must be signed and faxed to commence work. By signing this quote you are agreeing to prices and payment schedule above.

IRON NIKKEL CONSTRUCTION INC.  
Bakersfield, CA 93314 \*ironnikkel@gmail.com\* (661) 829-2929

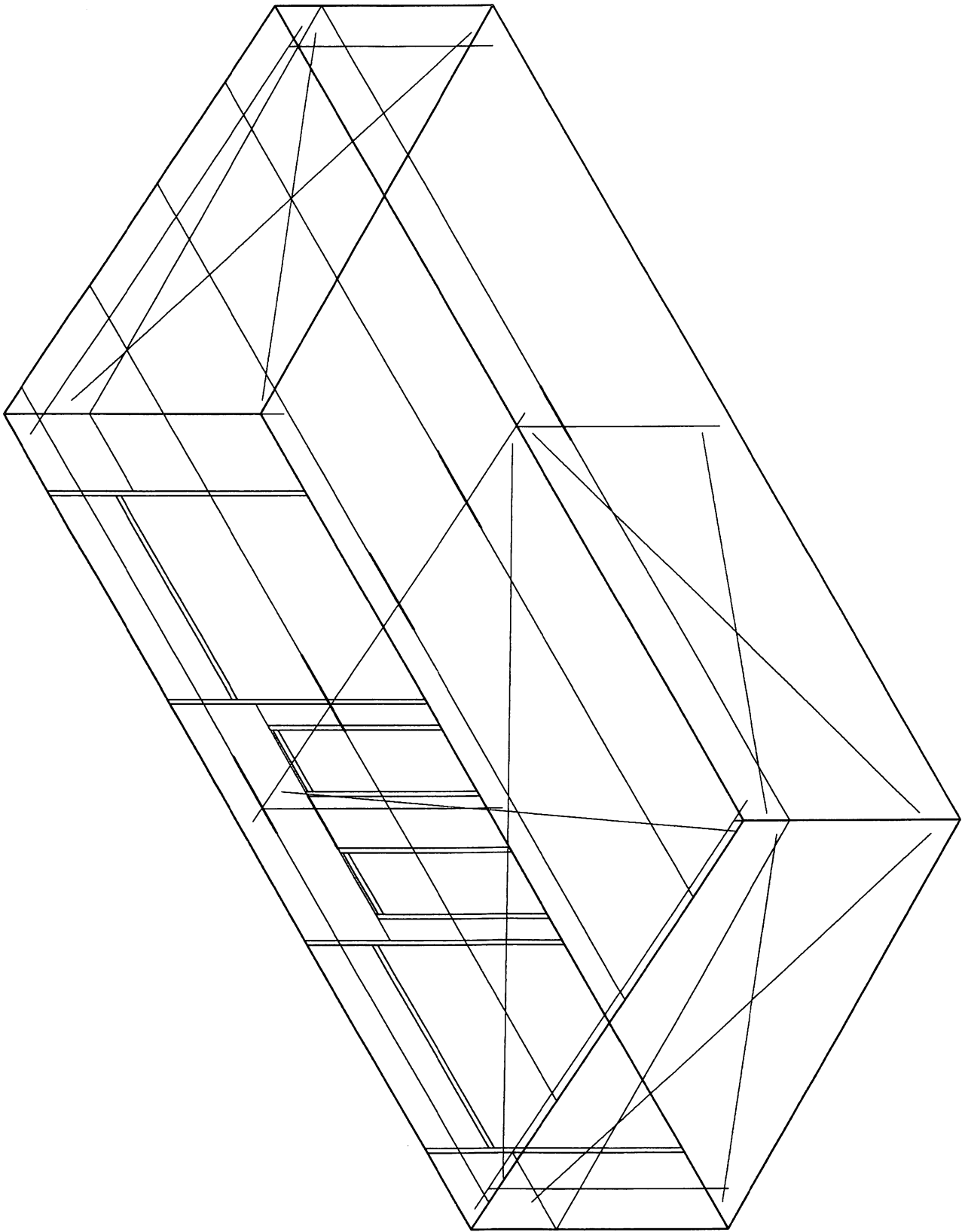

KEY PLAN

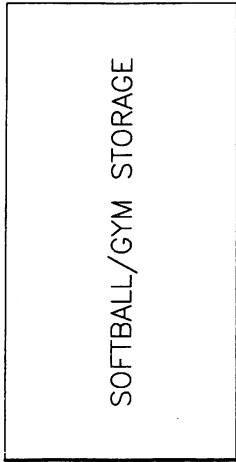

12  
1

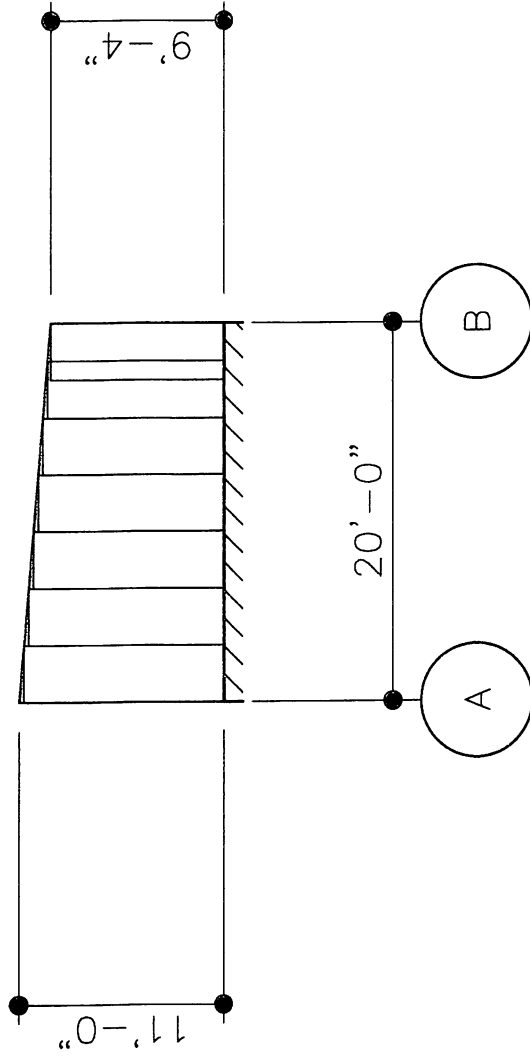

# WALL SHEETING ELEVATION AT LINE 1

PANELS: 26 GA. R-Panel - EVERGREEN

DO NOT USE FOR FINAL CONSTRUCTION

PROJECT NAME:  
TAFI COLLEGE

SHEET TITLE:  
7/30/2018 9:16 PM

CUSTOMER NAME:  
TAFI, CA

PRELIMINARY SHEETING ELEVATIONS

IRON NIKKEL

QUOTE NUMBER:  
07301801

BAKERSFIELD, CA

Quote  
Steel Buildings  
A PREFERRED COMPANY

KEY PLAN

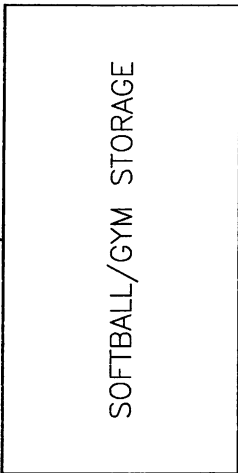

FRAMED OPENING SCHEDULE

ID	QTY	WIDTH	HEIGHT	SILL HEIGHT	LOCATED
1	2	10'-0"	8'-0"	0'-0"	FACTORY
2	2	3'-0"	7'-0"	0'-0"	FACTORY

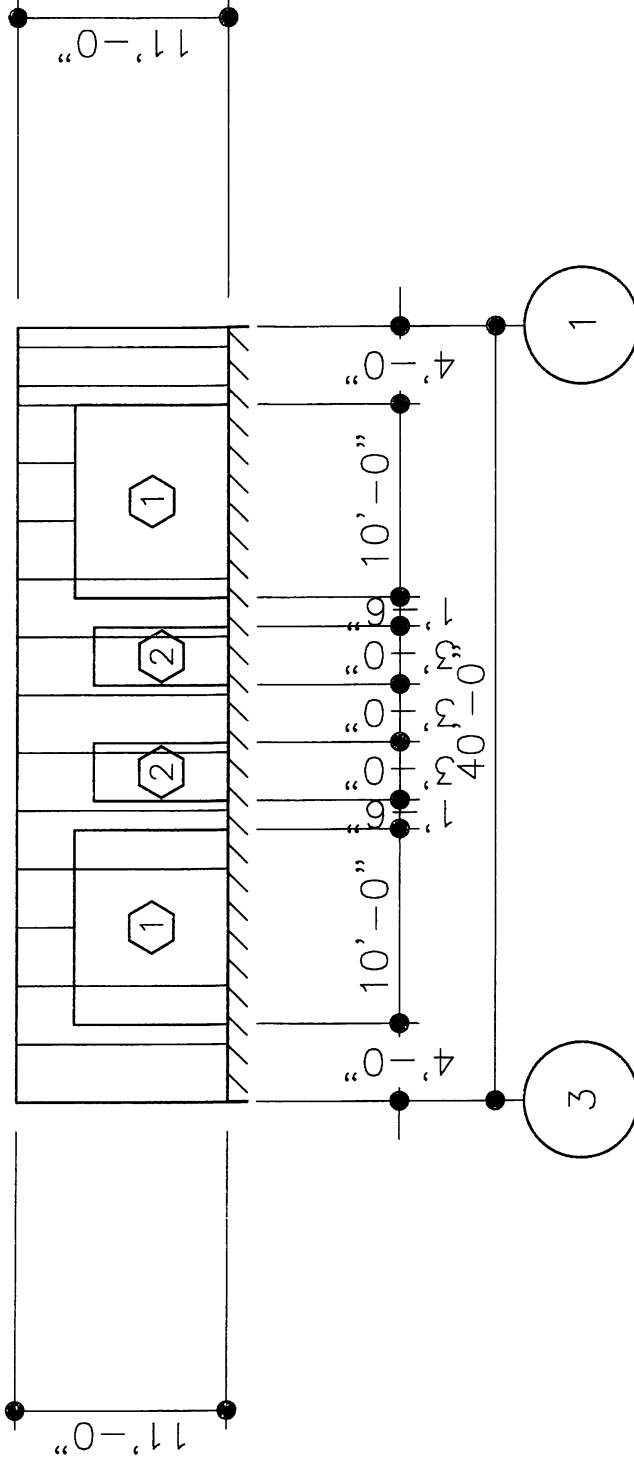

WALL SHEETING ELEVATION AT LINE A

PANELS: 26 GA. R-Panel - EVERGREEN

DO NOT USE FOR FINAL CONSTRUCTION

PROJECT NAME:  
TAFT COLLEGE  
TAFT, CA

SHEET TITLE:  
7/30/2018 8:11 PM

PRELIMINARY SHEETING ELEVATIONS

CUSTOMER NAME:  
IRON NIKKEL  
BAKERSFIELD, CA

SHEET NUMBER:  
WS8  
QUOTE NUMBER:  
07301801



KEY PLAN

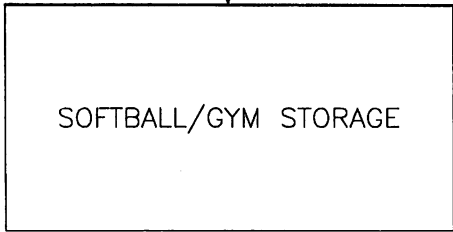

FRAMED OPENING SCHEDULE

(D)	QTY	WIDTH	HEIGHT	SILL HEIGHT	LOCATED
1	2	10'-0"	8'-0"	0'-0"	FACTORY

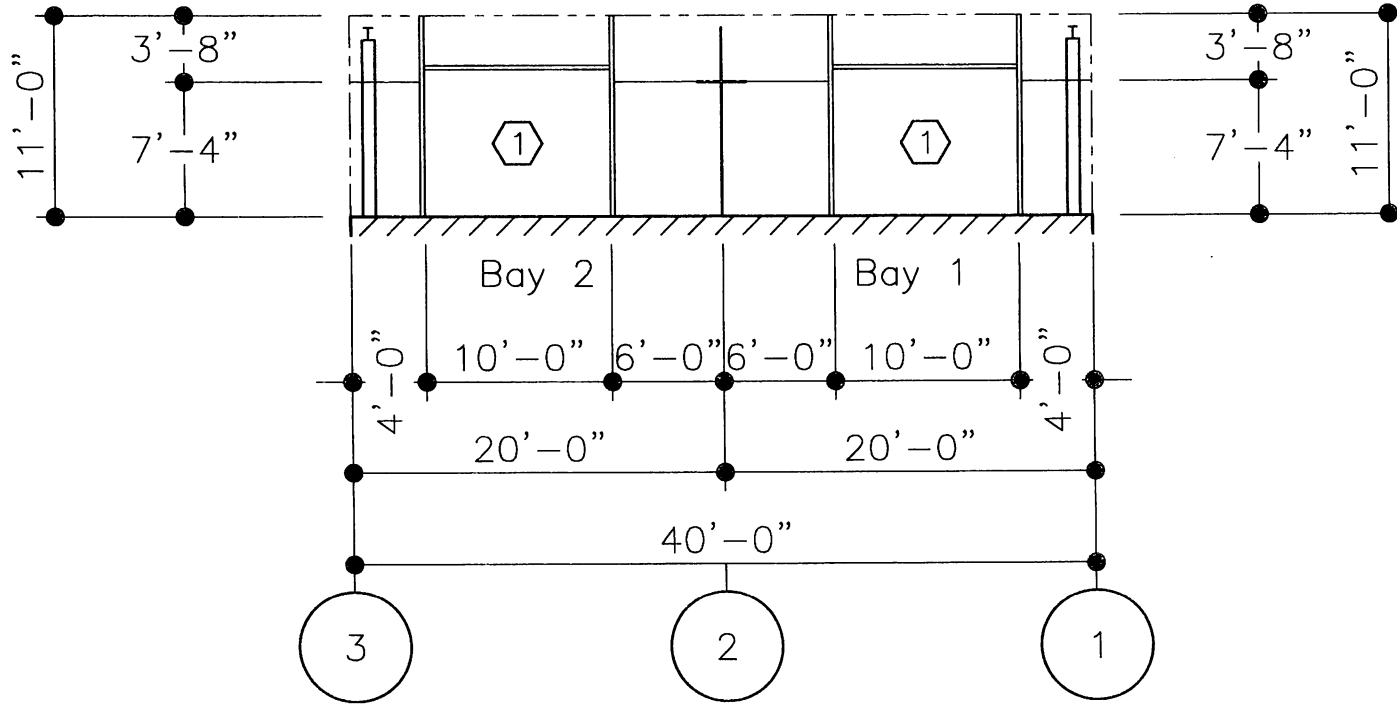

ELEVATION AT LINE A

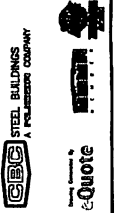

PROJECT NAME:  
TAFT COLLEGE  
TAFT, CA  
CUSTOMER NAME:  
IRON NIKKEL  
BAKERSFIELD, CA

DO NOT USE FOR FINAL CONSTRUCTION  
7/30/2018 6:10 PM  
PRELIMINARY STRUCTURAL ELEVATIONS  
SHEET NUMBER: ST8  
QUOTE NUMBER: 07301801



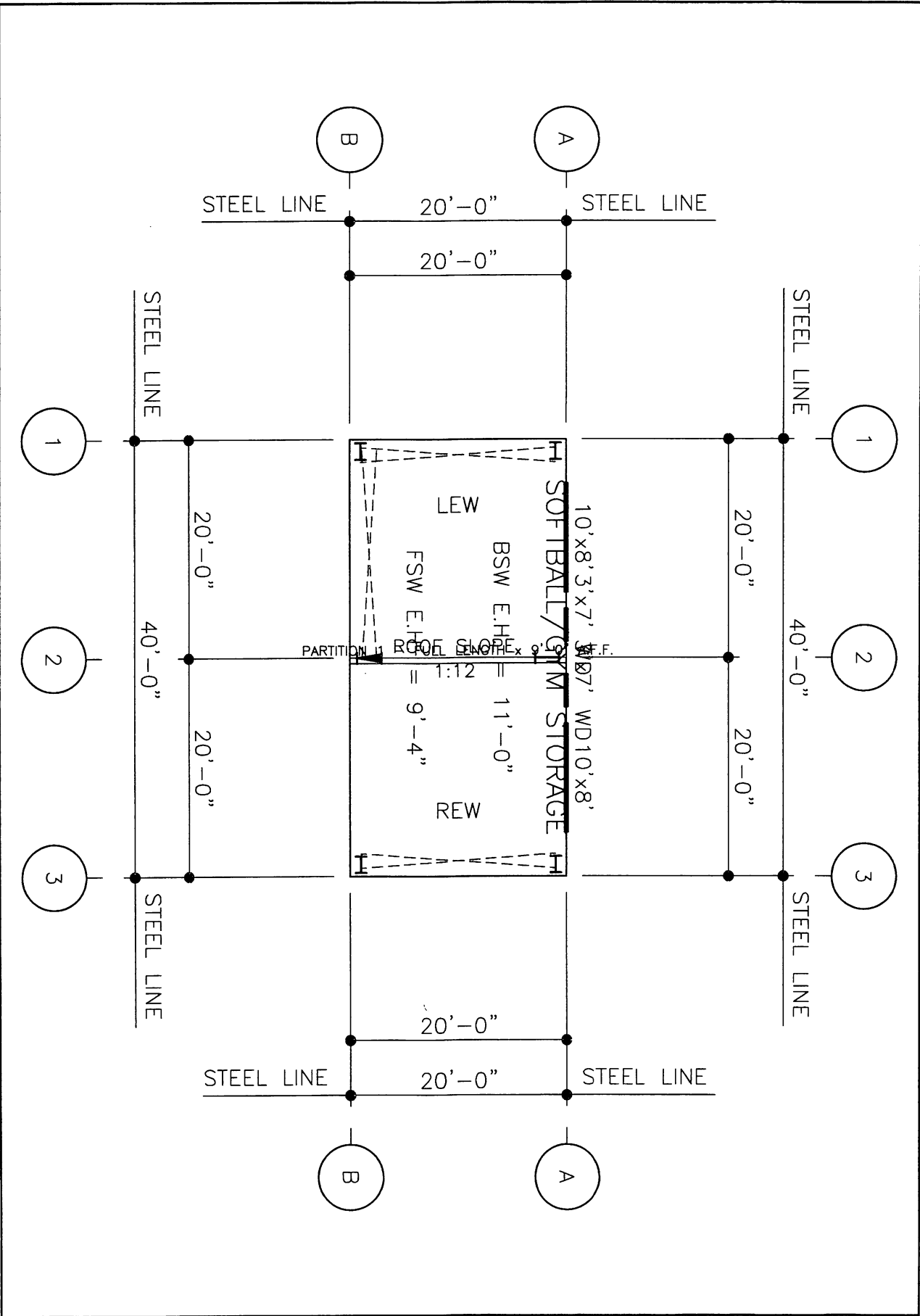

DO NOT USE FOR FINAL CONSTRUCTION

SHEET TITLE: 7/30/2018 9:09 PM  
**PRELIMINARY FLOOR PLAN**

SHEET NUMBER: FP1  
 QUOTE NUMBER: 07301801

PROJECT NAME:  
**TAFT COLLEGE**  
 TAFT, CA

CUSTOMER NAME:  
**IRON NIKKEL**  
 BAKERSFIELD, CA

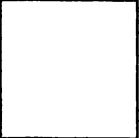

**Date:** October 1, 2018  
**Submitted by:** Brock McMurray, EVP of Administrative Services   
**Area Administrator:** Brock McMurray, EVP of Administrative Services  
**Subject:** Request for Approval

---

**Board Meeting Date:** October 10, 2018

**Title of Board Item:**

Request for Approval to Proceed with the G Buildings Door Hardware Phase Two Project.

**Background:**

This project is Phase Two of a project for installation of card readers in the G Modular Buildings, and has been approved by the State as part of our Deferred Maintenance program. Convergent Technologies, who has installed card readers on campus in the past, was contacted for a quote on the proposed work in order to maintain a continuity of technology in our campus card readers. The attached proposal from Convergent Technologies outlines the costs of this project totaling \$35,912.78. This proposal is within the budget for Deferred Maintenance.

It is my recommendation, along with AP Architects, that Taft College accept Convergent Technologies' quote for the G Buildings Door Hardware Phase Two Project and authorize work to begin.

**Terms (if applicable):**

Please see attached proposal from Convergent Technologies.

**Expense (if applicable):**

\$35,912.78

**Fiscal Impact Including Source of Funds (if applicable):**

This project will be funded from 2018/2019 Deferred Maintenance monies.

**Approved:** \_\_\_\_\_

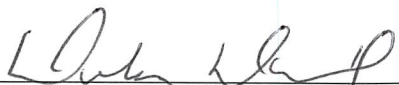
  
Dr. Debra Daniels, Superintendent/President



**Recommendation to Award**  
**18-19 SM Door Hardware Repairs-2**  
**Taft College**  
**West Kern Community College District**  
**430-0071**

**Date:** September 28, 2018  
**To:** Brock McMurray/ WKCCD  
**From:** Richard Treece / AP  
**Subject:** Recommendation to Award

VIA:  
 Email       FAX       UPS  
 Hand Delivery       Mail       Pick-Up

---

**Project Scope:**

- Project funding sources: CCCO 2018-19 Schedule Maintenance
- Project Budget: \$ 35,912.78
- Scope of work includes, but not limited to, the construction of the G Buildings Door Hardware Phase 2. Change the existing door hardware at the G-Building Classrooms to Card Access Control.
- .Estimated time of completion: January 2019

**Bid Evaluation:**

We have received a formal proposal for the **G Buildings Door Hardware** project in Taft, CA. One bid was received due to sole-sourcing of the card access system. The proposal is attached herein. This office recommends that the District award to Convirgent Technologies of Bakersfield, CA.

**Board Action Recommendation:**

**This office recommends Proposal SB00140496P be awarded in the amount of \$35,912.78 to Convirgent Technologies of Bakersfield, CA.**

Enclosures: Proposal Quotation SB00140496P  
DIR Registration Report



1667 North Batavia, Orange, California 92867  
Phone (661)857-4160 Mobile (661)857-4160  
jarrod.brunsmann@convergent.com

September 19, 2018

Taft College

Quotation: SB00140496P

29 Emmons Park Drive Taft, California 93268

Reference: G Building Phase 2 rev1 09-10-18

On behalf of our thousands of global colleagues, I want to personally thank you for considering Convergent Technologies for this project and for providing us with the opportunity to present this proposal addressing your electronic security needs. We are confident that this proven solution is both comprehensive and customized to meet your needs today and in the years ahead.

Convergent has developed a strong reputation for service excellence and is the only company recognized twice as the Systems Integrator of the Year by SDM Magazine. Most recently, Convergent was ranked the 4<sup>th</sup> largest global systems integrator. This recognition is, in part, a reflection of the strong relationships Convergent has developed with the industry's top technology manufacturers. Convergent Technologies has a strong history of success with similar solutions provided to other clients and would be happy to provide these references upon request.

Our guiding principal has always been to be a customer-focused and service-based company, supported by dedicated and certified professionals who strive to make a daily difference. Our vision of becoming our customers' best service provider is what drives everything we do. After achieving a successful on-time and on-budget project installation, Convergent will provide you with the industry's best on-going service. This service includes our 24/7 customer portal (iCare), designed to track service work orders, project progress, and provide you with detailed metric reporting for continuous improvement.

The following security proposal is specifically designed to meet your needs. As your single point of contact, please feel free to contact me with any additional questions you may have. Thank you again for considering Convergent Technologies as your partner for your electronic security needs.

## Scope of Work

- Provide and Install Power Supplies and Lenel boards at 3 locations (G1/G2, G9/10, G11/12)
- 110VAC and Network to be provided at each of the above locations by Taft College
- Provide and Install Card Readers, Door Contacts and Electrified Hardware at 8 Doors
- Program, Test and Commission System
- Door locations identified by yellow highlights on attached drawing

## Materials

Line	Qty	Part	Description	Unit Price	Extended Price
1			G9 & G10		
2	1.00	CNV-2DRF-MERC-STRD	2 DR STANDARD MERCURY, 75 Watt 12 and 24 VDC power supply, 4 relay fused outputs, mounts 1 mercury controller, 14X12 locking enclosure   LSP Model Number FPO75-B100C4E1M	\$ 390.77	\$ 390.77
3	1.00	SL2X2G	2"X2"X6' Gray Panduit	\$ 30.77	\$ 30.77
4	1.00	TC2G2	2"X2"X6' Gray Panduit Cover	\$ 7.69	\$ 7.69
5	2.00	NP712	Back Up Batteries (12VDC; 7AH Gell Cell)	\$ 21.54	\$ 43.08
6	1.00	LNL-2220	Intelligent Dual Reader Controller – 12 or 24 VDC @ 700mA, size (6" (152mm) W x 8" (203mm) L x 1" (25mm)H), (5 year lithium battery or 3 months full run) 6 MB standard cardholder flash memory, 50,000 of Event memory, maximum of 32 devices, On-board Ethernet, on-board two door control, OSDP Secure Channel encryption with OnGuard 7.2 and up,, eight inputs, four outputs, cabinet tamper and power fault input monitors. RoHS, CE, C-Tick and UL 294	\$ 1,684.62	\$ 1,684.62
7	1.00	LNL-1320	Dual Reader Interface Module (Series 2 –Supports OSDP Readers) – 12/24 VDC, 2 Reader interface, W/M, 8 inputs, 6 (5A) form C relays , RoHS, CE, C-Tick and UL294 certified	\$ 590.63	\$ 590.63
8	2.00	RP40	HID RP40 multiCLASS Smart Card Reader. 4.8" x 3.3" x 1.0"	\$ 207.69	\$ 415.38
9	2.00	SDC0745	ELR Kit for VD-22 Crash Bar	\$ 473.54	\$ 947.08
10	2.00	LRVD1R	98/99-33 VON DUPRIN SERIES REX KIT	\$ 86.40	\$ 172.80
11	2.00	CAT0402	4 Wire Transfer Hinge, 626 finish	\$ 101.56	\$ 203.12
12	2.00	N1178CG/ST2 CR1KSP	Nascom 3/4" Grey Door Contact 10pk	\$ 21.54	\$ 43.08
13			G11 & G12		
14	1.00	CNV-2DRF-MERC-STRD	2 DR STANDARD MERCURY, 75 Watt 12 and 24 VDC power supply, 4 relay fused outputs, mounts 1 mercury controller, 14X12 locking enclosure   LSP Model Number FPO75-B100C4E1M	\$ 390.77	\$ 390.77
15	1.00	SL2X2G	2"X2"X6' Gray Panduit	\$ 30.77	\$ 30.77
16	1.00	TC2G2	2"X2"X6' Gray Panduit Cover	\$ 7.69	\$ 7.69

Line	Qty	Part	Description	Unit Price	Extended Price
17	2.00	NP712	Back Up Batteries (12VDC; 7AH Gell Cell)	\$ 21.54	\$ 43.08
18	1.00	LNL-2220	Intelligent Dual Reader Controller – 12 or 24 VDC @ 700mA, size (6" (152mm) W x 8" (203mm) L x 1" (25mm)H), (5 year lithium battery or 3 months full run) 6 MB standard cardholder flash memory, 50,000 of Event memory, maximum of 32 devices, On-board Ethernet, on-board two door control, OSDP Secure Channel encryption with OnGuard 7.2 and up,, eight inputs, four outputs, cabinet tamper and power fault input monitors. RoHS, CE, C-Tick and UL 294	\$ 1,684.62	\$ 1,684.62
19	1.00	LNL-1320	Dual Reader Interface Module (Series 2 –Supports OSDP Readers) – 12/24 VDC, 2 Reader interface, W/M, 8 inputs, 6 (5A) form C relays , RoHS, CE, C-Tick and UL294 certified	\$ 590.63	\$ 590.63
20	3.00	RP40	HID RP40 multiCLASS Smart Card Reader. 4.8" x 3.3" x 1.0"	\$ 207.69	\$ 623.07
21	1.00	SDC0745	ELR Kit for VD-22 Crash Bar	\$ 473.54	\$ 473.54
22	1.00	LRVD1R	98/99-33 VON DUPRIN SERIES REX KIT	\$ 86.40	\$ 86.40
23	2.00	ND80PDEURH O62624VAE*	Electrified ND80 Lever with REX and Standard Core	\$ 648.66	\$ 1,297.32
24	3.00	CAT0402	4 Wire Transfer Hinge, 626 finish	\$ 101.56	\$ 304.68
25	3.00	N1178CG/ST2 CR1KSP	Nascom 3/4" Grey Door Contact 10pk	\$ 21.54	\$ 64.62
26	G1 & G2				
27	1.00	CNV-2DRF-MERC-STRD	2 DR STANDARD MERCURY, 75 Watt 12 and 24 VDC power supply, 4 relay fused outputs, mounts 1 mercury controller, 14X12 locking enclosure   LSP Model Number FPO75-B100C4E1M	\$ 390.77	\$ 390.77
28	1.00	SL2X2G	2"X2"X6' Gray Panduit	\$ 30.77	\$ 30.77
29	1.00	TC2G2	2"X2"X6' Gray Panduit Cover	\$ 7.69	\$ 7.69
30	2.00	NP712	Back Up Batteries (12VDC; 7AH Gell Cell)	\$ 21.54	\$ 43.08
31	1.00	LNL-2220	Intelligent Dual Reader Controller – 12 or 24 VDC @ 700mA, size (6" (152mm) W x 8" (203mm) L x 1" (25mm)H), (5 year lithium battery or 3 months full run) 6 MB standard cardholder flash memory, 50,000 of Event memory, maximum of 32 devices, On-board Ethernet, on-board two door control, OSDP Secure Channel encryption with OnGuard 7.2 and up,, eight inputs, four outputs, cabinet tamper and power fault input monitors. RoHS, CE, C-Tick and UL 294	\$ 1,684.62	\$ 1,684.62
32	1.00	LNL-1320	Dual Reader Interface Module (Series 2 –Supports OSDP Readers) – 12/24 VDC, 2 Reader interface, W/M, 8 inputs, 6 (5A) form C relays , RoHS, CE, C-Tick and UL294 certified	\$ 590.63	\$ 590.63
33	3.00	RP40	HID RP40 multiCLASS Smart Card Reader. 4.8" x 3.3" x 1.0"	\$ 207.69	\$ 623.07
34	3.00	SDC0745	ELR Kit for VD-22 Crash Bar	\$ 473.54	\$ 1,420.62

Line	Qty	Part	Description	Unit Price	Extended Price
35	3.00	LRVD1R	98/99-33 VON DUPRIN SERIES REX KIT	\$ 86.40	\$ 259.20
36	3.00	CAT0402	4 Wire Transfer Hinge, 626 finish	\$ 101.56	\$ 304.68
37	3.00	N1178CG/ST2 CR1KSP	Nascom 3/4" Grey Door Contact 10pk	\$ 21.54	\$ 64.62
38	Cable and Misc				
39	1.00	4461030	4 Element Composite Cable Plenum Yellow-Jacket	\$ 949.23	\$ 949.23
40	1.00	MISC PARTS	Mis. Parts	\$ 215.00	\$ 215.00

<b>Equipment Total</b>	\$	16,710.19
<b>Total Labor/Other Costs</b>	\$	16,993.35
<b>Freight/Warranty</b>	\$	997.75
<b>Tax if Applicable</b>	\$	1,211.49
<b>Total Project Price</b>	\$	35,912.78

# Phase II

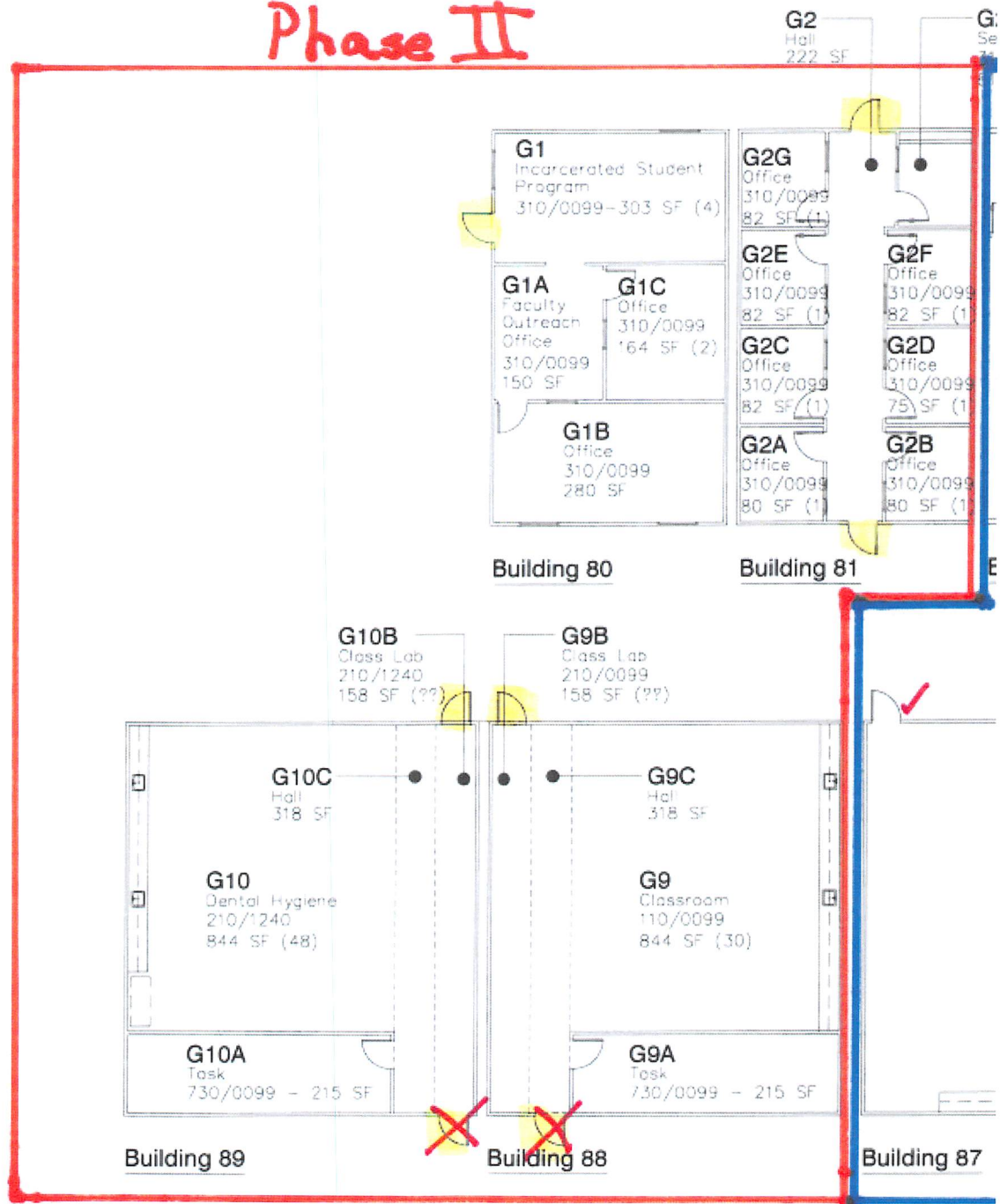



# Phase II

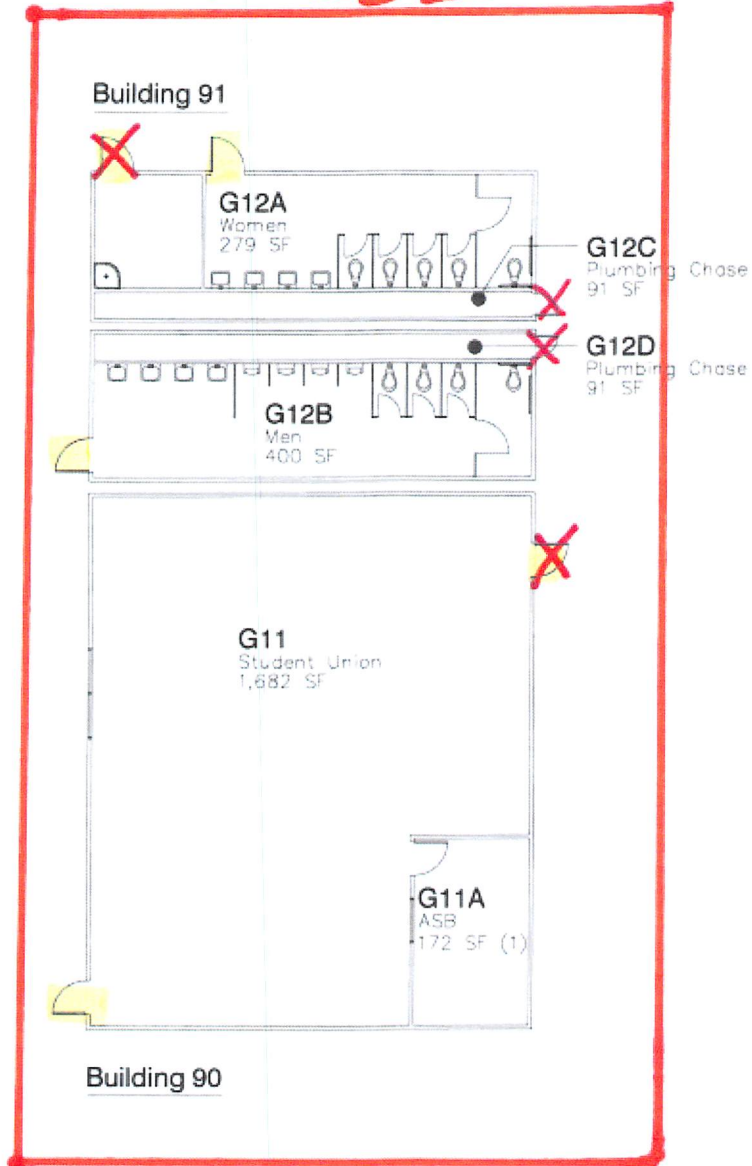

## Clarifications and Exclusion

1. All work proposed herein, shall be performed during normal business hours Monday through Friday 8:00 am - 5:00 pm.
2. Low voltage wiring shall be installed via open air code approved methods.
3. Provision or installation of conduit, wire, boxes, fittings or other electrical installation materials unless specifically listed under Inclusions or Bill of Materials.
4. Permits or associated fees are not included.
5. 110VAC to be provided by Taft College
6. Customer to provide static IP addresses and network connections at panel locations.
7. Customer to provide a secured staging & storage area for project related materials.
8. Pricing assumes that electronic Auto CAD files are available from customer for our use in creating submittal drawings.
9. Twenty-Five percent (25%) of the proposed sell price shall be payable to Convergent Technologies for project mobilization. Mobilization shall be invoiced and due upon customer acceptance of this proposal.
10. Proposal includes sales tax.
11. Anything in the Contract Documents notwithstanding, in no event shall either Contractor or Subcontractor be liable for special, indirect, incidental or consequential damages, including commercial loss, loss of use, or lost profits, even if either party has been advised of the possibility of such damages.
12. Convergent Technologies reserves the right to negotiate mutually acceptable contract terms and conditions with customer by making mutually agreeable changes to the formal contract included in the Bid Documents.

**Performance Items**

Items Included	
Applicable Taxes	Attend General Contractor Project Meetings
Attend Owner Project Meetings	Cable
Electrified Door Locking Hardware	Freight (prepaid)
Installation of Control Equipment Enclosures	Installation of Low Voltage Wire
Installation of Network Cabling to Card Readers	Installation of Wire and Cable
Installation of Wire Hangars	Material (listed in the BOM)
Mounting/Termination of Proposed Devices	One-Year Warranty on Labor
One-Year Warranty on Parts	Owner to Provide DHCP Lease Reservations for Network Connected Devices
Owner to Provide Static IP Addresses	Project Management
Servers by Others	System Engineering
System Meets Plans/Drawings	System Programming
Testing of all Proposed Devices	Wire
Workstations by Others	

Items Excluded	
120 VAC Power and Fused Disconnect Switch	120 VAC Power Receptacles
Additional Lighting Requirements for Cameras	Authority having Jurisdiction permit drawing (requires customer CAD)
Ceiling Tiles and Ceiling Grid Repairs	Connection to Building Fire Alarm Panel
Correction of Wiring Faults Caused by Others	Door wiring typical connections
Electrical Installation Permit	Engineering and Drawings
Equipment rack layout drawing	FA Permit and Plan Review Fees
Fire Stopping (Excludes Existing Penetrations)	Fire Watch
Floor Coverings for Lifts	Floor plan with device placement and numbering (requires customer CAD)
Horizontal Core Drilling	Installation of Bridle Rings
Installation of CCTV Cameras	Installation of Conduit, Boxes and Fittings
Installation of Control Panels	Installation of Intercom Systems
Installation of Intrusion Panels	Installation of Network Cabling to IP Cameras
Installation of Network Cabling to IP Intercoms	Installation of Specialty Backboxes
Installation of Terminal Cabinets	Installation of Video Recorders (DVR/NVR)
Lifts	Loading Software on Customer Provided Computer
Low Voltage Permits	On-Site Lockable Storage Facility
Operations & Maintenance Manuals	Owner Training
Panel Wall Elevation drawing (may require customer CAD)	Panel wiring point with to point connections
Patch and Paint	Payment & Performance Bonds
Record Documentation (As-Built)	Riser drawing with home run wiring
Servers by Convergent	Specialty Backboxes
Submittal Drawings	System is Design-Build
Terminal Cabinets	Termination of Control Equipment Enclosures
Vertical Core Drilling	Workstations by Convergent

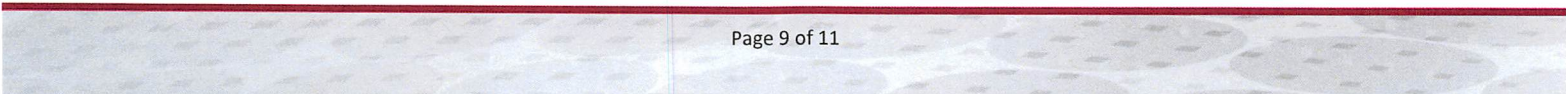

**Total Project Investment:**

**\$ 35,912.78**

Thank you for considering Convergent Technologies for your Security needs. If you have any questions or would like additional information, please don't hesitate to contact me immediately. If you would like to proceed with the scope of work as outlined in this proposal, please sign below and return to my attention.

Sincerely,

**Jarrold Brunsmann**  
Convergent Technologies  
Jarrod Brunsmann

By signing below, I accept this proposal and agree to the Terms and Conditions contained herein

\_\_\_\_\_  
Customer Name (Printed)

September 19, 2018  
\_\_\_\_\_  
Date

\_\_\_\_\_  
Authorized Signature

\_\_\_\_\_  
Title

## Convergent Technologies' Install Terms & Conditions

Throughout this Installation Proposal, the term, "Convergent" refers to the Convergent Technologies' affiliate operating in the state/province in which the work is being performed, specifically, "Convergent Technologies LLC" or "Convergent Technologies LTD".

### SECTION 1. THE WORK

This Installation Proposal takes precedence over and supersedes any and all prior proposals, correspondence, and oral agreements or representations relating to the work set forth in the attached scope of work ("Work"). This Installation Proposal commences on the Start Date as specified in the attached scope of work, and represents the entire agreement between Convergent and Customer (the "Agreement") and it may only be amended by a written document signed by both Convergent and Customer. In the event any provision of this Agreement is held to be invalid or unenforceable, the remaining provisions of this Agreement shall remain in full force.

Convergent agrees in accordance with the mutually agreed project schedule:

- To submit shop drawings, product data, samples and similar submittals if required in performing the Work;
- To pay for all labor, materials, equipment, tools, supervision, programming, testing, startup and documentation required to perform the Work in accordance with the Agreement;
- Secure and pay for permits and governmental fees, licenses and inspections necessary for proper execution and completion of the Work; and
- Hire subcontractors and order material to perform part of the Work, if necessary, while remaining responsible for the completion of the Work.

Customer agrees in accordance with the mutually agreed project schedule, and at no cost to Convergent:

- To promptly approve submittals provided by Convergent;
- To provide access to all areas of the facility which are necessary to complete the Work;
- To supply suitable electrical service as required by Convergent; and
- That in the event of any emergency or systems failure, reasonable safety precautions will be taken by Customer to protect life and property during the period of time from when Convergent is first notified of the emergency or failure and until such time that Convergent notifies the Customer that the systems are operational or that the emergency has cleared.

### SECTION 2. PRICING

Pricing and amounts proposed shall remain valid for 30 days unless otherwise specified. Price includes only the material listed based on Convergent's interpretation of plans and specifications unless noted otherwise. Additional equipment, unless negotiated prior to order placement, will be billed accordingly. Sales taxes, (and in Canada GST/PST) and any other taxes assessed on Customer shall be added to the price upon invoice to Customer.

### SECTION 3. INVOICE REMITTANCE AND PAYMENT

Customer agrees to pay Convergent twenty-five (25%) percent of the total price as a mobilization fee at the time of executing this Agreement.

If the Work is performed over more than a month, Convergent will invoice Customer each month for the Work performed during the previous month. Customer agrees to pay the amount due to Convergent as invoiced, within thirty (30) days of the date of such invoice. If the Work is completed in less than one month, Customer agrees to pay Convergent in full after the Work has been performed within thirty (30) days of the date of being invoiced. Invoices shall not include or be subject to a project retention percentage. If Customer is overdue in any payment to Convergent, Convergent shall be entitled to suspend the Work until paid, and charge Customer an interest rate 1 and 1/2% percent per month, (or the maximum rate permitted by law), and may avail itself of any other legal or equitable remedy. Customer shall reimburse Convergent costs incurred in collecting any amounts that become overdue, including attorney fees, court costs and any other reasonable expenditure.

### SECTION 4. WARRANTY

Convergent provides the following warranty to the Customer:

For the period of one (1) year, commencing at the earlier of substantial completion of the Work, or first beneficial use, ("Warranty Period"):

- That Work performed under this Agreement will be of good quality;
- That all equipment will be new unless otherwise required or permitted by this Agreement;
- That the Work will be free from defects not inherent in the quality required or permitted; and
- That the Work will conform to the requirements of this Agreement.

The Customer's sole remedy for any breach of this warranty is that Convergent shall remove, replace and/or repair at its own expense any defective or improper Work, discovered within the Warranty Period, provided Convergent is notified in writing of any defect within the Warranty Period.

Any equipment or products installed by Convergent in the course of performing the Work hereunder shall only carry such warranty as is provided by the manufacturer thereof, which Convergent hereby assigns to Customer without recourse to Convergent. Upon request of Customer, Convergent will use all reasonable efforts to assist Customer in enforcing any such third party warranties. This warranty excludes remedy for damage or defect caused by abuse, modifications not executed by Convergent, improper or insufficient maintenance, improper operation, or normal wear and tear under normal usage. NO FURTHER WARRANTIES OR GUARANTIES, EXPRESS OR IMPLIED, ARE MADE WITH RESPECT TO ANY GOODS OR SERVICES PROVIDED UNDER THIS AGREEMENT, AND ANY IMPLIED WARRANTIES OF MERCHANTABILITY OR FITNESS FOR A PARTICULAR PURPOSE ARE EXPRESSLY DISCLAIMED.

### SECTION 5. CHANGES

Without invalidating this Agreement or any bond given hereunder, Customer or Convergent may request changes in the Work. Any changes to the Work and any adjustment to the Agreement Price or the time for completion of the Work shall be in writing signed by both Customer and Convergent. If Customer orders any additional work or causes any material interference with Convergent's performance of the Work, Convergent shall be entitled to an equitable adjustment in the time for performance and in the Agreement Price, including a reasonable allowance for overhead and profit.

### SECTION 6. FORCE MAJEURE

Neither Customer nor Convergent shall be responsible or liable for, shall incur expense for, or be deemed to be in breach of this Agreement because of any delay in the performance of their respective obligations pursuant to this Agreement due solely to circumstances beyond their reasonable control ("Force Majeure") and without the fault or negligence of the party experiencing such delay, provided that the party experiencing the delay shall promptly give written notification to the other party within five (5) days after such party has learned of the Force Majeure. A Force Majeure event shall include, Convergent Technologies' Install Terms & Conditions

but not be limited to: accident, fire, storm, water, flooding, negligence, vandalism, power failure, installation of incompatible equipment, improper operating procedures, source current fluctuations or lighting. If performance by either party is delayed due to Force Majeure, the time for that performance shall be extended for a period of time reasonably necessary to overcome the effect of the delay. Any Services required by Convergent due to reasons set forth in this Force Majeure Section shall be charged to Customer in addition to any amounts due under this Agreement.

### SECTION 7. INSURANCE

Convergent shall have the following insurance coverage during the term of this Agreement, and shall provide certificates of insurance to the Customer prior to beginning work hereunder:

Worker's Compensation	Statutory Limits
Employer's Liability	\$1,000,000 per occurrence /aggregate
Commercial General Liability	\$1,000,000 per occurrence/aggregate \$2,000,000 general aggregate
Automobile Liability	\$1,000,000 per occurrence/aggregate
Excess/Umbrella Liability	\$4,000,000 per occurrence/aggregate

All insurance policies carried by Convergent hereunder shall be primary to and noncontributory with the insurance afforded to Customer, and shall name the Customer as "additional insured", with respect to liability arising out of work performed by Convergent, as applicable, but only to the extent of liabilities falling within the indemnity obligations of Convergent, pursuant to the terms of this Agreement. Convergent shall provide to the Customer no less than thirty (30) days notice prior to the termination or cancellation of any such insurance policy.

### SECTION 8. INDEMNIFICATION

Convergent shall indemnify and hold Customer harmless from and against claims, damages, losses and expenses, (including, but not limited to, reasonable attorney's fees), attributable to bodily injury, sickness, disease or death, or to destruction of tangible property, but only to the extent caused by: a) the negligent or willful acts or omissions of Convergent or Convergent's employees or subcontractors while on Customer's site, or b) the malfunction of the equipment supplied by Convergent, or c) Convergent's breach of this Agreement.

IN NO EVENT SHALL EITHER CONVERGENT OR CUSTOMER BE LIABLE TO THE OTHER PARTY HERETO FOR SPECIAL, INDIRECT, INCIDENTAL OR CONSEQUENTIAL DAMAGES, INCLUDING COMMERCIAL LOSS, LOSS OF USE OR LOST PROFITS, EVEN IF THAT PARTY HAS BEEN ADVISED OF THE POSSIBILITY OF SUCH DAMAGES. IN NO EVENT WILL CONVERGENT BE LIABLE TO CUSTOMER FOR ANY AMOUNTS IN EXCESS OF THE AMOUNTS PAID BY CUSTOMER TO CONVERGENT.

It is understood and agreed by the parties hereto that Convergent is or may be providing monitoring and or intrusion products which are designed to provide notification of certain events but are not intended to be guarantees or insurers against any acts for which they are supposed to monitor or inform. As required by the monitoring and intrusion industry and the manufacturers thereof, Convergent's indemnification obligation pursuant to Section 8 herein, does not apply to the extent the loss indemnified against is caused by any monitoring or intrusion product or software provided by but not manufactured by Convergent. Convergent shall have no liability to Customer for any losses to the extent such losses are caused by the monitoring or intrusion product or software. Customer shall indemnify, defend, and hold harmless Convergent, from and against all claims, lawsuits, damages, losses and expenses by persons not a party to this Agreement, but only to the extent caused by such monitoring or intrusion product or software provided by but not manufactured by Convergent.

### SECTION 9. COMPLIANCE WITH LAW, EEO & SAFETY

This Agreement shall be governed and construed in accordance with the laws of the state/province in which the Work is being performed. Convergent agrees to comply with all laws and regulations relating to or governing the Work. Convergent agrees to comply with all reporting requirements imposed by law or this Agreement. Convergent shall comply with all safety related laws and regulations and with the safety program of the Customer, provided such program is supplied to Convergent prior to beginning work.

In the event that Convergent discovers or suspects the presence of hazardous materials, or unsafe working conditions at Customer's facility where the Work is to be performed, Convergent is entitled to stop the Work at that facility if such hazardous materials, or unsafe working conditions were not provided by or caused by Convergent. Convergent in its sole discretion shall determine when it is "safe" to return to perform the Work at Customer's facility. Convergent shall have no responsibility for the discovery, presence, handling, removing or disposal of or exposure of persons to hazardous materials in any form at the Customer's facility. Customer shall indemnify and hold harmless Convergent from and against claims, damages, losses and expenses, including but not limited to, reasonable attorney's fees, arising out of or resulting from undisclosed hazardous materials, or unsafe working conditions at Customer's facility.

### SECTION 10. DISPUTES

In the event of any dispute between Convergent and Customer, Convergent and Customer shall first attempt to resolve the dispute in the field, but if that is not successful, then in a meeting between authorized officers of each company. If settlement attempts are not successful, then the dispute shall be subject to and decided by mediation or arbitration. Such mediation or arbitration shall be conducted in accordance with the Construction Industry Mediation or Arbitration Rules of the American Arbitration Association currently in effect and shall be a final binding resolution of the issues presented between the parties.

### SECTION 11. MISCELLANEOUS

Neither party to this Agreement shall assign this Agreement without the prior written consent of the other party hereto. Convergent may assign this Agreement to any of its parents, subsidiary or affiliated companies or any entity majority owned by Convergent.

Notices shall be in writing and addressed to the other party, in accordance with the names and addresses of the parties as shown above. All notices shall be effective upon receipt by the party to whom the notice was sent.

A waiver of the terms hereunder by one party to the other party shall not be effective unless in writing and signed by a person with authority to commit the Customer or Convergent and delivered to the non-waiving party according to the notice provision herein. No waiver by Customer or Convergent shall operate as a continuous waiver, unless the written waiver specifically states that it is a continuous waiver of the terms stated in that waiver.

The Sections regarding invoicing, warranty and indemnity shall survive the termination of this Agreement.



Taft College  
WEST KERN COMMUNITY COLLEGE DISTRICT

**18-19 SM Door Hardware Repairs-2**

BID DATE: 9/19/2018  
JOB NUMBER: 430-0071

# DIR REGISTRATION REPORT

NOA DATE: 10/10/2018  
CONTRACT AMOUNT: \$ 35,912.78

CONTRACTOR'S LEGAL NAME	DIR Registration #	License Type/Number(s)	Registration Date	Expiration Date
Convergint Technologies	1000002787	986407	5/17/2018	6/30/2019

**Date:** October 1, 2018

**Submitted by:** Name

**Area Administrator:** Brock McMurray, EVP of Administrative Services *Bv*

**Subject:** Request for Approval

---

**Board Meeting Date:** October 10, 2018

**Title of Board Item:**

Request for Approval to Proceed with the 18-19 Deferred Maintenance Energy Management System Controller Replacement Project

**Background:**

This is a project for replacement of the Energy Management System (EMS) controllers in the Administration and Science buildings, which are outdated. Failure to update the EMS controllers could present security issues. Please see the attached bid proposal from Alcorn Aire, the sole-source bidder for this project.

It is my recommendation, along with AP Architects, that Taft College accept Alcorn Aire's bid for the EMS Controller Replacement Project and authorize work to begin.

**Terms (if applicable):**

Please see the attached proposal from Alcorn Aire.

**Expense (if applicable):**

\$16,875.00.

**Fiscal Impact Including Source of Funds (if applicable):**

This project will be funded from 2018/2019 Deferred Maintenance and local funds.

**Approved:**   
\_\_\_\_\_  
Dr. Debra Daniels, Superintendent/President





**Recommendation to Award**  
**18-19 SM EMS Replacement Admin**  
**Taft College**  
**West Kern Community College District**  
**430-0072**

**Date:** September 28, 2018  
**To:** Brock McMurray/ WKCCD  
**From:** Richard Treece / AP  
**Subject:** Recommendation to Award

VIA:

Email       FAX       UPS  
 Hand Delivery       Mail       Pick-Up

---

**Project Scope:**

- Project funding sources: CCCO 2018-19 Schedule Maintenance Funds / Local
- Project Budget: \$16,875.00
- Scope of work includes, but not limited to, the replacement of the Administration building Energy Management System (EMS) Controller which is outdated.
- Estimated time of completion: January 2019

**Bid Evaluation:**

We have received a formal proposal for the **18-19 SM EMS Replacement Admin** project in Taft, CA. One bid was received due to sole-sourcing of the EMS. The proposal is attached herein. This office recommends that the District award to Alcorn Aire of Bakersfield, CA.

**Board Action Recommendation:**

**This office recommends this Proposal be awarded in the amount of \$16,875.00 to Alcorn Aire of Bakersfield, CA.**

Enclosures: Proposal  
DIR Registration Report



Taft College  
WEST KERN COMMUNITY COLLEGE DISTRICT  
**18-19 SM EMS Replacement Admin**

# DIR REGISTRATION REPORT

NOA DATE: 10/10/2018  
CONTRACT AMOUNT: \$ 16,875.00

BID DATE: 9/19/2018  
JOB NUMBER: 430-0072

CONTRACTOR'S LEGAL NAME	DIR Registration #	License Type/Number(s)	Registration Date	Expiration Date
Alcorn Aire	1000000823	735144	5/2/2018	6/30/2019

# Proposal Form



Po Box 60356, Bakersfield CA 93386  
Telephone: (661) 323-1992 Fax (661) 323-5160

QUOTATION TO:

JOB NAME/ADDRESS

**Taft College**  
**Re: EMS upgrades for Administration and Science buildings**  
**Attn: Richard**

THE CONDITIONS PRINTED EITHER ON THE REVERSE SIDE OR ATTACHED ARE PART HEREOF.  
This work or price quotation does not include detection, abatement, encapsulation or removal of asbestos or products, materials, or equipment containing asbestos.

SCOPE OF WORK:

September 28, 2018

Alcorn Aire Inc is proposing to install new Johnson Controls FX-80's for the outdated FX-40 controller in the Administration and Science buildings. The older FX-40 controllers cannot be updated to the current software revisions, this is causing Java and security issues. Alcorn will install the FX-80 controllers at both locations doing all electrical, programming, and graphical interfaces to make this a complete project.

Price \_\_\_\_\_ \$ 16,875.00

"Contractors are required by law to be licensed and regulated by the Contractors' State License Board which has jurisdiction to investigate complaints against contractors if a complaint is filed within three years of the date of the alleged violation. Any questions concerning a contractor may be referred to the Registrar, Contractors' State License Board, P. O. Box 26000, Sacramento, CA 95826."California State License No. 735144Your signed acceptance of this Bid Contract within 30 days from September 28, 2018 shall, upon the acceptance of the Seller, constitute a contract to perform the work described above, including all Terms and Conditions contained herein. Seller shall be defined to mean Alcorn Aire Inc. or its assigns. Buyer shall be defined to mean the Owner, Owners/Agent, Builder, Architect, lessees, or any person acting on behalf of any of the foregoing. Prepared in duplicate September 28, 2018. Prepared for Alcorn Aire, Inc.

Jason Alcorn  
Alcorn Aire Inc  
661-323-1992



TERMS AND CONDITIONS TO PROPOSAL FORM

1. All work shall be performed during normal working hours unless otherwise stated herein.
2. Alcorn Aire Inc. agrees to maintain in full force and effect a Workmen's Compensation Insurance policy and a Comprehensive Liability Insurance policy in substantial amounts to protect all parties to this agreement, furnishing certificates of insurance, if required by Buyer.
3. Buyer shall prepare the premises to permit free movement and erection of materials, providing necessary openings, supports, cutting, patching, necessary public utility and steam services, and pay all fees in accordance with codes and ordinances unless otherwise indicated in this Bid Contract.
4. In the event that the Seller encounters any asbestos product or material in the course of performing its work, the Seller shall have the right to immediately discontinue its work and remove its employees from the project, or that portion of the project wherein such product or materials were encountered, until such time as any hazards connected therewith are abated, encapsulated or removed and/or it is determined that no hazard exists; further, Seller shall receive an extension of time to complete its work and compensation for delays encountered and compensation for any change in the sequence of method or its work occasioned as a consequence of said encounter.
5. Alcorn Aire Inc. extends manufacturer's standard warranties on all new equipment, misuse or abuse excepted, for a period not to exceed one year from date of first beneficial use, which shall be defined as the Start-up Date. Alcorn Aire Inc. Conditioning guarantees all repaired materials, parts and labor for a period of ninety (90) days from the date of first beneficial use. There are no warranties, expressed or implied, other than the above unless so noted herein.  
Seller shall not be liable for any consequential damages including, but not limited to, liquidated damages, loss of rent, interest expense, extended overhead or any other delay damages of any kind, nature or description. It is expressly understood and agreed that the only liability of Seller is to replace defective workmanship or material as herein above set forth.
6. Alcorn Aire Inc. agrees that for a period of ninety (90) days following the initial operation of the installation, it will replace any refrigerant loss caused by defects in the equipment, material, parts, or workmanship furnished under this contract. Replacement of refrigerant due to failure or defects other than items furnished by Seller is not included as a part of this agreement.
7. Alcorn Aire Inc. shall not be liable for the corrosive or erosive action of liquids and/or gases upon the equipment specified and no part of such equipment shall be deemed defective by reason of its failure to resist physical or chemical action of such elements or items upon such equipment.
8. This agreement shall not be binding until duly accepted by an authorized officer of Alcorn Aire Inc. No person has authority to make or claim any representation, warranty, term, promise, or condition, expressed or implied, statutory or otherwise, which is not expressed herein. This agreement constitutes the entire agreement between the parties and supersedes and revokes any previous agreement, written or oral, with respect to the labor and equipment covered hereby and may not be amended or modified except in writing executed by the parties hereto.
9. Under no circumstances shall the liability of Seller arising out of the sale or erection of the equipment hereunder, or arising out of its use, whether on warranties or otherwise, in any case exceed the lesser of the following: (a) Cost of correcting defects in the equipment or workmanship; or (b) the difference in value between the installation as installed and the cost of the original installation thereof, if installed strictly as in the contract documents set forth. And in no event shall any claims be made by either party against the other for consequential damages.
10. The Seller shall not be bound by any plans and specifications or conditions, existing or otherwise, that have not been presented to or delivered to it for the purpose of submitting this bid, nor shall the Seller be bound by any city ordinances, State laws or other governmental regulations not in effect at the time of submitting this bid, or which had become obsolete and which no longer was enforced by such public body enacting the same.
11. The Seller shall be excused for any delay in completion of this Bid Contract caused by acts of God, including but not limited to, wind, rain, flood, storm, landslide, subsidence and earthquake; acts of neglect of owner or architect or by any employee or agent of either; acts of neglect of separate contractors employed by owner; acts of public utilities or governmental or public bodies or their agents; material shortages; labor trouble, labor slowdowns; strikes; union activity causing a reduction in productivity; fire; casualty; delay in transportation; changes ordered in the work; failure of Buyer to make payments to Seller as required under this Bid Contract, or other causes beyond the reasonable control of Seller, any of which shall automatically entitle Seller to reasonable or necessary extensions of the completion date of the work and to an equitable adjustment of the contract price to compensate Seller for all costs and expenses of additional labor, service, equipment or material and extended overhead resulting from any such delay.  
If any of the materials specified are not readily available, the Seller may substitute equally efficient materials or fixtures of generally similar character in lieu of the equipment, materials or fixtures specified, and it shall allow any differential between the original cost of the materials specified and the materials furnished.  
In the event of inability to obtain labor at union scale or without paying a premium above such scale, Seller may delay performance until same shall be obtainable without

- premium payment or at the option of the Buyer the latter may require the use of materials or labor requiring the payment of such excess cost, but upon condition that the Buyer shall pay such excess.
12. No additional work will be performed unless it is authorized in writing by the Buyer. If the Buyer refuses to sign a written work authorization or change order for the extra work, Seller reserves the right to refuse to perform the extra work.
13. Should either party hereto bring suit in court to enforce the terms hereof, any judgment awarded shall include court costs and reasonable attorney's fees to the successful party.
14. Seller assumes no responsibility for the design on those jobs where Seller prepares working or shop drawings from designs furnished by others. Seller assumes no responsibility whatsoever for design or operative end result under any contract unless there is affirmatively stated on the obverse side of this Bid Contract, a direct undertaking on Seller's part so to do.
15. Seller may suspend further performance under this Bid Contract upon three (3) days written notice to the Buyer in the event the Buyer is in breach of this Bid Contract for breach other than non-payment. Notice need not be given if work is suspended due to non-payment or due to the failure of the Buyer to pay for change orders as provided herein. In the event Seller elects to suspend performance, Seller shall be entitled to reimbursement costs, including profit and overhead, upon the Buyer bringing payments current or issuing proper change orders for extra work. Such costs will equal actual losses sustained by Seller in terminating and restarting work.
16. This contract is entered into upon the understanding that in the prosecution of any work herein specified Seller will be allowed sufficient time for the performance of said work on the basis of a normal eight-hour day, and in the event that Buyer or any subcontractor require Seller to perform such labor on an overtime basis, then such additional expense of every kind and character as Seller may be required to incur on account of said overtime labor, shall constitute an additional charge herein.
17. It is agreed that Buyer is to provide without cost to Seller, proper hoisting conveyances and scaffolding (including the use of engineer) at times so as to not delay Seller's part of the work, unless otherwise indicated in this proposal.
18. Any loss or damage to Seller's work, materials or equipment occurring at the site of the project occasioned by fire, flood, earthquake, windstorm, riot or civil commotion shall be protected by Builders Risk Insurance procured by the contractor or owner without cost to Seller and Seller shall receive a proportionate share of the amount of any payment loss under any such policy or policies according as Seller's interest may appear.
19. Notwithstanding any provision in the plans, specifications, contract between prime contractor and owner, general conditions, or any contract documents executed by and between contractor and owner having to do with the subject now stated, Seller shall not be liable for the cost of correcting defects occasioned by the acts or omissions of employees of other subcontractors, the prime contractor, owner or any segregated contractor, to work performed by Seller. Before Seller proceeds with any corrective work to repair such damage, the prime contractor, or other person contracting with Seller in this Bid Contract, shall give Seller an unqualified instruction to proceed with the work upon their responsibility to compensate Seller therefor as an extra.
20. The Seller expressly reserves the right to assign all or any portion of its rights and/or duties under this Bid Contract with or without notice to the Buyer herein.
21. In the event of a conflict between the terms and conditions of this Bid Contract and terms and conditions stated in the plans and specifications, or any other contract document, including the prime contract between owner and prime contractor, the terms of this Bid Contract shall govern.
22. If, in Seller's opinion, Buyer's credit becomes impaired, Seller may, at its option, suspend work and deliveries under this contract until it has received full settlement or security for services rendered and is satisfied as to Buyer's credit for further shipments. If Buyer fails or refuses to make such payment, or give such security, then the full amount due under this contract at such time, for labor and material and/or equipment furnished shall immediately become due and payable and Seller shall have the right and the option to terminate this agreement. In the event that a suspension of this contract is required because of Buyer's doubtful credit, an extension of the time fixed for the performance of this contract equal to the time of such suspension, shall automatically occur. If legal action is filed to effect collection of any sums due hereunder, Seller shall be entitled to reasonable attorney fees in addition to all other damages found to be due hereunder.

ACCEPTED:

By: \_\_\_\_\_  
(Authorized Signature)

Name/Title.

**Date:** September 28, 2018  
**Submitted by:** Norberto Lopez, Curriculum Technician  
**Area Administrator:** Dr. Debra Daniels, Superintendent/President  
**Subject:** Request for Approval

---

**Board Meeting Date:** October 10, 2018

**Title of Board Item:**

Course Inactivations

**Background:**

The Curriculum and General Education Committee as well as the Applied Technologies Division recommends the following course inactivations.

**Applied Technologies Division**

The Applied Technologies Division has moved to inactivate the following IES courses. The program is once again being revised and these courses are no longer included in the degree and certificate programs.

1. IES 1050 Hazardous Materials
2. IES 1052 Respiratory Protection
2. IES 1053 Principles of Ergonomics
3. IES 1054 Permit Required Confined Space
4. IES 1058 Occupational Safety and Health Standards for the Construction Industry
5. IES 1059 Trainer Course in Occupational Safety and Health Standards for the Construction Industry
6. IES 1061 Occupational Safety and Health for General Industry

**Fiscal Impact Including Source of Funds (if applicable):**

None

**Approved:**   
\_\_\_\_\_  
Dr. Debra Daniels, Superintendent/President

**Date:** September 28, 2018  
**Submitted by:** Norberto Lopez Jr, Curriculum Technician  
**Area Administrator:** Dr. Debra Daniels, Superintendent/President  
**Subject:** Request for Approval

---

**Board Meeting Date:** October 10, 2018

**Title of Board Item:**

Course Revisions

**Background:**

Under accreditation requirements, academic institutions are expected to review and update its courses to ensure they meet current standards.

Applied Technologies Division

Applied Technologies has revised the Business Capstone course as well as changed the course acronyms from IES to OSH to better align with Industry needs:

BUSN	2900	Business Capstone
IES	1500	Occupational Safety and Health Compliance
IES	1532	Industrial Hygiene
IES	2000	Occupational Safety and Health Capstone
IES	2065	Trainer Course in Occupational Safety and Health Standards

Math and Science Division

The Math Science Division has revised the following course outlines as part of the five-year review cycle:

MATH	1540	Precalculus Mathematics
PHYS	2221	General Physics
STAT	1510	Elementary Statistics

Liberal Arts Division

The Liberal Arts Division has revised the following course outline as part of the five-year review cycle:

PHIL	1501	Introduction to Philosophy
------	------	----------------------------

**Fiscal Impact Including Source of Funds (if applicable):**

None

Approved:  \_\_\_\_\_  
Dr. Debra Daniels, Superintendent/President



## BOARD AGENDA ITEM

**Date:** September 28, 2018  
**Submitted by:** Norberto Lopez Jr., Curriculum Technician  
**Area Administrator:** Dr. Debra Daniels, Superintendent/President  
**Subject:** Request for Approval

---

**Board Meeting Date:** October 10, 2018

**Title of Board Item:**

New Courses

**Background:**

Under accreditation requirements, academic institutions are expected to review and update its curriculum to ensure they meet current standards.

**Learning Support Division**

The following courses were created because of the need for students to develop the skills necessary for transfer planning, as a part of a scaffolding sequence of student success courses.

1. STSU 1525 Transfer Planning
2. STSU 1550 Funding a Transfer Plan

**Math & Science Division**

This transferrable course was developed to meet the demands of AB 705 and give non-STEM students more flexibility to satisfy their degree requirements.

1. MATH 1510 College Algebra for Liberal Arts

**Social Science Division**

The development of this course is for students who are exploring the possibility of becoming an elementary teacher.

1. EDUC 1520 Introduction to Elementary Education for the Contemporary

**Fiscal Impact Including Source of Funds (if applicable):**

None

**Approved:** \_\_\_\_\_

  
Dr. Debra Daniels, Superintendent/President



Prepared by: J. Rangel-Escobedo

Reviewed by: C.Duron

Reviewed by: D. Bogle

Reviewed by: J. Chaidez

Date Prepared: Fall 2018

**Student Success (STSU) 1525 Transfer Planning (2 unit) CSU**

**Advisory: Eligibility for English 1500 strongly recommended.**

**Total Hours: 32 hours lecture. 64 outside of class hours. (96 Total Student Learning Hours)**

**Catalog Description:**

**This course provides strategies for academic success and needed research skills essential for developing a comprehensive transfer plan. Topics will include the transfer transitioning process, major preparation and admission selection criteria, student support resources, evaluation of universities, clarification of educational goals and cost of attendance.**

**Type of Class/Course: Degree Credit**

**Textbooks:**

**1. Tyler, Lucia D., and Susan E. Henninger. *The Ultimate Guide to College Transfer: From Surviving to Thriving*. Rowman & Littlefield Publishers, 2017.**

**Additional Required Materials:**

**1. Taft College Catalog/Student Handbook, current edition**

**Course Objectives:**

**By the end of the course, a successful student will be able to:**

- 1. Identify the skills necessary for successful transfer.**
- 2. Develop skills and knowledge necessary to reach educational goals.**
- 3. Compare and contrast the differences between the UC, CSU, private, and out-of-state educational institutions.**
- 4. Develop an educational plan congruent with transfer and major goals.**
- 5. Learn goal implementation techniques.**
- 6. Identify college expenses and potential financial aid and budgetary resources available including those associated with tuition, housing, and other university fees.**
- 7. Research various educational institutions.**

8. Explain general education, major preparation, minimum entrance requirements and competitive GPA necessary for admission to transfer school of choice.
9. Examine and compare the role, function, and structure of higher education options within California and the nation.
10. Examine the relationship between education choices and personal values, interests, skills, and personality traits.
11. Identify personal barriers that may impede transfer success.
12. Discuss and locate campus support services.
13. Demonstrate proficiency in use of Internet resources related to college/career information: Using ASSIST database to access major preparation information and explore majors; using online catalogs, researching financial aid options, and conducting career and university research.

**Course Scope and Content:**

**Unit I**            **Basics of a Transfer Plan**

- A. Benefits of college education
- B. History of higher education systems in California
- C. Language of higher education

**Unit II**            **Transfer Goal Development Preparation**

- A. Identifying major appropriate for transfer admission
- B. Identifying personal skills, values, and interests
- C. Identifying the link between a major and a career

**Unit III**           **Transfer Systems**

- A. The California State University System
  1. CSU minimum admission requirements
  2. CSU websites
  3. Impaction at the CSU
  4. Benefits of Associate's Degree for Transfer
- B. The University of California System
  1. Minimum admission requirements
  2. Transfer Pathways
  3. Transfer Admission Guarantee: TAGs
  4. UC websites
- C. Private Colleges
- D. Out of State College

**Unit IV**           **Transfer Resources**

- A. ASSIST
- B. FAFSA (Free Application for Federal Student Aid)
- C. On-line catalogs
- D. Occupational handbook /Career Center web page, research links
- E. Housing

**Unit V Application Process**

- A. Tools needed for application process
- B. Application timelines and procedures
- C. The personal statements/ insight questions
- D. Letters of recommendations

**Unit VI Financing Transfer Options**

- A. Financial Aid
- B. Scholarships
- C. Loans

**Learning Activities Required Outside of Class.**

**The students in the class will spend a minimum of 4 hours per week outside of the regular class time doing the following:**

- 1. Studying
- 2. Answering questions
- 3. Completing required reading
- 4. Problem solving activities and exercises
- 5. Written work
- 6. Observations or participating in activity related to the course content

**Methods of Instruction**

- 1. Assigned reading from text and selected references
- 2. Inclass and online lectures, demonstrations, and films
- 3. Discussions
- 4. Group projects/activities
- 5. Self evaluation of student education plan

**Methods of Evaluation**

- 1. Journals
- 2. Written Assignments
- 3. Chapter quizzes and unit tests
- 4. Reports and/or projects/case study
- 5. Final Exam

**Supplemental Data:**

<b><u>TOP Code:</u></b>	<b><u>493013 – Academic Guidance</u></b>
-------------------------	--

<b><u>Sam Priority Code:</u></b>	<b><u>E: Non-Occupational</u></b>
<b><u>Funding Agency:</u></b>	<b><u>E: Non-Occupational</u></b>
<b><u>Program Status:</u></b>	<b><u>2: Not Program Applicable</u></b>
<b><u>Noncredit Category:</u></b>	<b><u>Y: Not Applicable, credit course</u></b>
<b><u>Special Class Status:</u></b>	<b><u>N: Course is not a special class</u></b>
<b><u>Basic Skills Status:</u></b>	<b><u>N: Not Applicable</u></b>
<b><u>Prior to College Level:</u></b>	<b><u>Y: Not Applicable</u></b>
<b><u>Cooperative Work Experience:</u></b>	<b><u>N: Course is not a part of a cooperative education program</u></b>
<b><u>Eligible for Credit by Exam:</u></b>	<b><u>Yes</u></b>
<b><u>Eligible for Pass/No Pass:</u></b>	<b><u>Yes</u></b>

Prepared by: J. Rangel-Escobedo

Reviewed by: C.Duron

Reviewed by: D. Bogle

Reviewed by: J. Chaidez

Date Prepared: Fall 2018

**Student Success (STSU) 1550 Funding a Transfer Plan (1 unit) CSU**

**Prerequisite: none**

**Advisory: Eligibility for English 1500 strongly recommended.**

**Total Hours: 16 hours lecture + 32 Outside of class hours (48 Total Student Learning Hours)**

**Catalog Description: This course is an introduction to financial resources and management associated with the costs of transferring from the California Community College to a university. Topics covered in this course include personal income, budgeting, scholarships, grants, federal loans, private loans, work-study, and common issues and misconceptions associated with financing college.**

**Type of Class/Course: Degree Credit**

**Textbook:**

**Chaney, Kalman. *Paying for College, 2019 Edition: Everything You Need to Maximize Financial Aid and Afford College (College Admissions Guides)*. Princeton Review, 2018.**

**Additional Required Materials:**

**Taft College Catalog/Student Handbook, current edition**

**Course Objectives:**

**By the end of the course, a successful student will be able to:**

- 1. Demonstrate knowledge of present and future financial costs associated with transfer**
- 2. Identify and distinguish between common financial resources used for transfer.**
- 3. Demonstrate knowledge of financial responsibility associated with college enrollment**
- 4. Demonstrate knowledge of money and debt management.**
- 5. Demonstrate knowledge of budgeting**
- 6. Demonstrate effective communication strategies with financial aid departments**

**Course Scope and Content:****Unit I Understanding Transfer Costs**

- A. Comparing costs of different types of institutions
- B. Comparing fee structure for:
  - a. CSU System
  - b. UC System
  - c. Private Non Profit
  - d. Private For Profit
  - e. Out of State Transfer
- C. Language of higher education

**Unit II Financial Resources**

- A. Scholarships
- B. Grants
- C. Federal Loans
- D. Private Loans
- E. Work-Study
- F. Military Benefits
- G. Loan Forgiveness Programs

**Unit III University Calculation of Financial Need**

- A. Expected Family Contribution
- B. Communicating with the Financial Aid Office
- C. Recalculation of Need

**Unit IV Credit Scores/ Loan Eligibility**

- A. Common Loan Vendors
- B. Limits on Loan Access/Co-Signer
- C. Repayment Terms
- D. Credit worthiness rules for students and parents
- E. Default Consequences

**Unit V Consumer Awareness/Fraud Protection**

- A. College Disclosures
- B. College Scorecard
- C. Scholarship Application Vendors
- D. Debt Relief & Consolidation Scams

**Unit VI Decision Making and Budgeting**

- A. The role of emotions, attitudes, and behavior in making financial decisions
- B. The role of family or support system in financial decision making
- C. Weighing cost and benefits of transfer

**Learning Activities Required Outside of Class**

**The students in the class will spend a minimum of 4 hours per week outside of the regular class time doing the following:**

1. **Studying**
2. **Answering questions**
3. **Completing required reading**
4. **Problem solving activities and exercises**
5. **Written work**
6. **Observations or participating in activity related to the course content**

**Methods of Instruction**

1. **Assigned reading from text and selected references**
2. **In-class and online lectures, demonstrations, and films**
3. **Discussions**
4. **Group projects/activities**
5. **Self-evaluation of student education plan**

**Methods of Evaluation**

1. **Journals**
2. **Written Assignments**
3. **Chapter quizzes and unit tests**
4. **Reports and/or projects/case study**
5. **Final Exam**

**Supplemental Data:**

<b><u>TOP Code:</u></b>	<b><u>493013 – Academic Guidance</u></b>
<b><u>Sam Priority Code:</u></b>	<b><u>E: Non-Occupational</u></b>
<b><u>Funding Agency:</u></b>	<b><u>E: Non-Occupational</u></b>
<b><u>Program Status:</u></b>	<b><u>2: Not Program Applicable</u></b>
<b><u>Noncredit Category:</u></b>	<b><u>Y: Not Applicable, credit course</u></b>

<b><u>Special Class Status:</u></b>	<b><u>N: Course is not a special class</u></b>
<b><u>Basic Skills Status:</u></b>	<b><u>N: Not Applicable</u></b>
<b><u>Prior to College Level:</u></b>	<b><u>Y: Not Applicable</u></b>
<b><u>Cooperative Work Experience:</u></b>	<b><u>N: Course is not a part of a cooperative education program</u></b>
<b><u>Eligible for Credit by Exam:</u></b>	<b><u>Yes</u></b>
<b><u>Eligible for Pass/No Pass:</u></b>	<b><u>Yes</u></b>



Prepared by: D. Jones  
Reviewed by: R. Payne  
Reviewed by: M. Martinez  
Date Prepared: August 28, 2018  
C & GE approved:  
Board Approved:  
Semester effective:

Mathematics (MATH) 1510 College Algebra for Liberal Arts (4 Units) CSU:

Prerequisite: Successful completion of Intermediate Algebra (Math 1060) with a grade of C or better

Prerequisite knowledge and skills: Before entering the course, the student should be able to:

1. identify numbers as belonging to specified sets, and graph discrete and continuous sets of real numbers,
2. perform the basic arithmetic operations with positive and negative real numbers, plus raising to powers,
3. know and apply the rules of exponents and the order of operations in algebraic calculations,
4. apply the properties of addition and multiplication for real numbers and identify their use in practice,
5. solve linear equations and inequalities in one variable, and analyze and solve applications leading to such equations or inequalities,
6. solve and graph the solutions of compound inequalities or absolute value inequalities in one variable,
7. perform addition, subtraction, multiplication and division of polynomials,
8. factor simple polynomials, with special emphasis on trinomials quadratic in form, and solve related polynomial equations,
9. add, subtract, multiply and divide rational algebraic expressions, and simplify to lowest terms,
10. solve equations involving rational algebraic expressions, and analyze and solve word problems leading to such equations.,
11. simplify radical expressions involving numbers and/or variables,
12. use fractional exponents,
13. perform addition, subtraction, multiplication and division of expression involving radicals and complex numbers and simplify the results, including rationalization of denominators,
14. solve equations that involve radicals,
15. solve quadratic equations in one variable, and equations quadratic in form, by factoring, completing the square, and the quadratic formula,
16. analyze and solve application problems requiring the use of quadratic equations,
17. solve and graph quadratic inequalities in one variable,

Humanities Communication & Critical Thinking**Justification for Addition to Taft College General Education:**

GE/C&A – Student demonstrates the ability to communicate knowledge, information, ideas, and feelings, and enhance the ability to evaluate, problem solve, and make decisions.

[Click here to enter text.](#)

- 18. graph points in the rectangular coordinate system, and straight lines from ordered pairs obtained from its equation,**
- 19. determine the slope of the line between any specified pair of points,**
- 20. know the slope forms of the equation of a straight line, and be able to determine the equation of a particular straight line from specified input information,**
- 21. solve and graph linear inequalities in two variables,**
- 22. solve linear systems of equations in two or three variables algebraically, and solve those in two dimensions graphically,**
- 23. analyze and solve application problems requiring the use of linear systems of equations in two or three variables,**
- 24. evaluate determinants and use them to solve linear systems of equations,**
- 25. determine whether or not a specified relation is a function,**
- 26. for a function, compute the value of the function given the value of the independent variable, and be able to construct the inverse of simple functions in numeric or algebraic terms,**
- 27. identify the quadratic equation representing a specific conic section, and be able to draw the graph of a conic section by analyzing its equation, or to write the equation of a specified conic section,**
- 28. solve nonlinear systems of equation involving the intersection of two conic sections or a conic section and a straight line,**
- 29. compute and graph specified exponential and logarithmic functions,**
- 30. know the properties of logarithms (product, quotient, power and change of base rules) and be able to use them in practical numerical computations using a table of common logarithms or a calculator, and**
- 31. solve simple exponential and logarithmic equations.**

**Hours and Units Calculations: 64 hours lecture + 128 Outside-of-class Hours (192 Total Student Learning Hours) = 4 Units**

**Catalog Description: College level course in algebra for majors in the Liberal Arts: polynomial, rational, radical, exponential, absolute value, and logarithmic functions; systems of equations; theory of polynomial equations; analytic geometry C-ID:MATH 150**

**Type of Class/Course: Degree Credit**

**Texts: Lial, Hornsby, Schneider, Daniels. *Essentials of College Algebra*. 12<sup>th</sup> ed. Pearson, 2017.**

**Additional Required Materials: N/A**

**Course Objectives:**

**By the end of the course, a successful student will be able to:**

- 1. Analyze and investigate properties of functions;**

2. Synthesize results from the graphs and/or equations of functions;
3. Solve and apply equations including rational, linear, absolute value, polynomial, exponential, and logarithmic equations;
4. Solve linear and nonlinear systems of equations and inequalities;
5. Apply functions and other algebraic techniques to model real world applications and;
6. For additional topics:
  - a. Recognize the relationship between functions and their inverses graphically and algebraically
  - b. Apply transformations to the graphs of functions
  - c. Use linear programming to solve problems
  - d. Apply techniques for finding zeros of polynomials and roots of equations
  - e. Solve and apply linear systems using matrices and determinants
  - f. Analyze conics algebraically and graphically
  - g. Use combinatorial rules to calculate probabilities
  - h. Use sequences and series to solve application problems.

### Course Scope and Content:

#### Unit I      Equations and Inequalities

- A. Linear and Polynomial Equations
- B. Applications and Modeling with Linear Equations
- C. Complex Numbers
- D. Quadratic and Radical Equations
- E. Rational Equations and Applications
- F. Linear and Nonlinear Inequalities
- G. Absolute Value Equations and Inequalities

#### Unit II      Graphs and Functions

- A. Rectangular Coordinates and Graphs
- B. Definition and Evaluation of Functions and Domain and Range of Functions
- C. Linear Functions
- D. Equations of Lines
- E. Graphs of Radical, Exponential, and Absolute Value Functions
- F. Graphing Techniques
- G. Algebra of Functions and Function Operations and Composition

#### Unit III      Polynomial and Rational Functions

- A. Polynomial and Quadratic Functions
- B. Synthetic Division
- C. Characterization of the Zeros of Polynomial Functions
- D. Polynomial Functions: Graphs including intercepts and vertices
- E. Rational Functions: Graphs including asymptotes, intercepts, and vertices

**Unit IV Inverse, Exponential, and Logarithmic Functions**

- A. Inverse Functions**
- B. Exponential Functions**
- C. Logarithmic Functions**
- D. Evaluating Logarithms and the Change-of-Base Theorem**
- E. Exponential and Logarithmic Equations**

**Unit V Systems and Matrices**

- A. Systems of Linear Equations**
- B. Matrix Solution of Linear Systems**
- C. Determinant Solution of Linear Systems**
- D. Nonlinear Systems of Equations**
- E. Systems of Inequalities and Linear Programming**
- F. Properties of Matrices**
- G. Matrix Inverses**

**Learning Activities Required Outside of Class**

**The students in the class will spend a minimum of 8 hours per week outside of the regular class time doing the following:**

- 1. Studying**
- 2. Skill practice**
- 3. Completing required reading**
- 4. Problem solving activity or exercise**

**Methods of Instruction**

- 1. Lecture-demonstrations and sample problems by instructor**
- 2. Class discussions**
- 3. Audiovisual presentations**

**Methods of Evaluation**

- 1. Computational or non-computational problem-solving demonstrations, including:**
  - a. exams**
  - b. homework problems**
  - c. quizzes**
  - d. projects**

**Supplemental Data:**

<b><u>TOP Code:</u></b>	<b><u>170100: Mathematics, General</u></b>
-------------------------	--

<b><u>Sam Priority Code:</u></b>	<b><u>E: Non-Occupational</u></b>
<b><u>Funding Agency:</u></b>	<b><u>Y: Not Applicable (funds not used)</u></b>
<b><u>Program Status:</u></b>	<b><u>1: Program Applicable</u></b>
<b><u>Noncredit Category:</u></b>	<b><u>Y: Not Applicable, Credit Course</u></b>
<b><u>Special Class Status:</u></b>	<b><u>N: Course is not a special class</u></b>
<b><u>Basic Skills Status:</u></b>	<b><u>N: Course is not a basic skills course</u></b>
<b><u>Prior to College Level:</u></b>	<b><u>Y: Not applicable</u></b>
<b><u>Cooperative Work Experience:</u></b>	<b><u>N: Is not part of a cooperative work experience education program</u></b>
<b><u>Eligible for Credit by Exam:</u></b>	<b><u>E: Credit By Exam</u></b>
<b><u>Eligible for Pass/No Pass:</u></b>	<b><u>C: Pass/No Pass</u></b>

Prepared by: V. Jacobi  
Reviewed by: K. Carlson  
Date Prepared: April 17, 2018  
C & GE approved:  
Board approved:  
Semester effective:

**Education (EDUC) 1520 Introduction to Elementary Education for the Contemporary Educator (3 Units) CSU**

**Prerequisite: None**

**Advisory: Successful completion of ENGL 1500 strongly recommended**

**Hours and Unit Calculations:**

**Total Contact Hours 48 hours lecture + 96 Outside-of-class Hours (144 Total Student Learning hours) hours (including 50 45 hours fieldwork) = 3 Units 189 total hours 3 Units of Credit**

**Catalog Description: The course is an introduction to concepts and issues related to teaching diverse learners in today's contemporary schools, Kindergarten through grades 12 (K-12). Topics include teaching as a profession and career, historical and philosophical foundations of the American education system, current educational issues, California's content standards and frameworks, and teacher performance standards. In addition to lectures, this course requires a minimum of 50 -45 hours of structured fieldwork in public elementary classrooms that represent California's diverse student demographics and includes cooperation with at least one carefully selected and campus-approved certificated classroom teacher.**

**Type of Class/Course: Degree credit**

**Texts: Eggen, Paul and Don Kauchak. *Revel Introduction to Teaching: Becoming a Professional*. 6<sup>th</sup> ed., Pearson, 2017.**

**Carlson, Kamala. *Increasing Metacognitive Active Learning Strategies*. 1st ed., Kamala Carlson, 2011.**

**Carlson, Kamala and Jessica Grimes. *Supersonic Writing Tips: Grammar Cards*. 4th ed., Kamala Carlson and Jessica Grimes, 2017.**

**Additional Required Materials: None**

**Course Objectives:**

**By the end of the course, a successful student will be able to:**

1. **Identify personal meanings related to teaching, reflecting upon why they want to become a teacher, examining personal characteristics, assumptions and beliefs, subject matter knowledge, experiences, and goals that could affect their development as a teacher;**
2. **Articulate basic purposes of schooling and trace the history of its development;**
3. **Describe the multiple roles and functions of the teachers and other school personnel in meeting the diverse needs of students;**
4. **Demonstrate knowledge of professional standards, ethics, and professionalism in the classroom and school visits;**
5. **Demonstrate an understanding of educational issues in a global context;**
6. **Demonstrate knowledge of the impact of cultural contexts on learning;**
7. **Analyze ecological challenges outside the classroom that impact student learning and identify schools and community resources that address these challenges;**
8. **Demonstrate skill in implementing established protocols for visiting schools and classrooms;**
9. **Demonstrate skill in implementing observational protocols;**
10. **Relate course content to real classrooms through satisfactory completion of a minimum of 50 45 hours of approved fieldwork including structured assignments, observations, and reflections;**
11. **Describe examples of teaching events that implement elements of the California Standards for the Teaching Profession and Teaching Performance Expectations;**
12. **Analyze the use of state adopted academic content and performance standards;**
13. **Compare and contrast classroom environments; and,**
14. **Recognize and describe individual differences among students and identify strategies and accommodations to address these differences.**

**Course Scope and Content:**

**Unit I Do I Want to Be a Teacher?**

- A. **What Is It Like to Be a Teacher?**
- B. **The Teaching Profession**
- C. **Teaching in Rural, Suburban, and Urban Schools**

**Unit II Changes in American Society: Their Influences on Today's Students**

- A. **Changes in American Families**
- B. **Changes in Our Students**
- C. **The Influence of Socioeconomic Factors on Students**
- D. **Promoting Resilience in Students at Risk**

**Unit III Student Diversity: Culture, Language, Gender and, Exceptionalities**

- A. **Cultural Attitudes and Values**



- B. Culturally Responsive Teaching
- C. Technology and Teaching: Technology Access Issues
- D. Learners with Exceptionalities

**Unit IV Education in the United States: Its Historical Roots**

- A. The Colonial Period (1607-1775)
- B. The Early National Period (1775-1820)
- C. The Common School Movement: The Rise of State Support for Public Education (1820-1865)
- D. The Modern Era: Schools as Instruments for National Purpose and Social Change

**Unit V Educational Philosophy and Your Teaching**

- A. Philosophy and Philosophy of Education
- B. Branches of Philosophy
- C. Philosophy of Education
- D. Developing Your Philosophy of Education

**Unit VI Choosing a School**

- A. How Do Schools Function?
- B. School Levels
- C. Finding a Good School
- D. Issues You'll Face in Teaching: Grade Retention

**Unit VII Governance and Finance: Regulating and Funding Schools**

- A. Governance: How Are Schools Regulated and Run?
- B. School Finance: How Are Schools Funded?
- C. Emerging Issues in School Governance and Finance
- D. Is a Quality Education Only for the Wealthy?

**Unit VIII School Law: Ethical and Legal Influences on Teaching**

- A. Law, Ethics, and Teacher Professionalism
- B. Teachers' Rights and Responsibilities
- C. Technology and Restrictions on Teachers' Freedom to Communicate with Students
- D. Teaching About Religion in the Schools

**Unit IX The School Curriculum in an Era of Standards**

- A. Curriculum Decisions and My Classroom
- B. Components of the Curriculum
- C. Forces that Influence the Curriculum
- D. Controversial Issues in the Curriculum

**Unit X Classroom Management: Creating Productive Learning Environments**

- A. Creating a Productive Learning Environment

B. Involving Parents

C. Intervening When Misbehavior Occurs

D. Teaching in Challenging Classrooms

Unit XI      **Becoming an Effective Teacher**

A. Student Motivation and Effective Teaching

B. Planning for Effective Teaching

C. Putting Plans into Action: Implementing Instruction and Assessing Learning

D. Effective Instruction in Urban Classrooms

Unit XII      **Educational Reform and You**

A. Educational Reform and My Teaching

B. Reform: Focus on the Curriculum

C. Reform: Focus on Schools

D. Reform: Focus on the Teacher

Unit XIII     **Developing as a Professional**

A. Entering the Profession

B. Your First Year of Teaching

C. What Does It Take to Be Effective with All Students?

D. Career-Long Professional Development

Unit XIV      **Contemporary Issues Facing School's Today**

A. Standards

B. Inclusion

C. High stakes Testing

D. Bilingual Education

E. Social Issues

F. Standardized Curriculum

Unit XV      **Schools and Community**

A. Local Community

B. Global Perspective

Learning Activities Required Outside of Class

The students in the class will spend a minimum of -6 hours per week outside of the regular class time doing the following:

1. Reading
2. Homework
3. Research
4. Writing

5. Classroom observations

Methods of Instruction

1. Lecture
2. Class discussions based on readings and observations, and/or
3. Discussion boards via Canvas
4. Group and individual panels and presentations
5. Role play
6. Guest speaker
7. Library

Methods of Evaluation

1. Quizzes
2. Exams
3. Presentations
4. Informal writing (examples include journals, annotations, reader responses, and responses to questions)
5. Formal essays
6. Research project
7. Write in MLA-(APA?)conventions
8. Portfolio development
9. Field experience (50 45 hours)

Supplemental Data:

<u>TOP Code:</u>	<u>0801.00 – Education, General (Pre-Professional) (Transfer)</u>
<u>Sam Priority Code:</u>	<u>E: Non - Occupational</u>
<u>Funding Agency:</u>	<u>Y: Not Applicable</u>
<u>Program Status:</u>	<u>1: Program Applicable</u>
<u>Noncredit Category:</u>	<u>Y: Not applicable</u>
<u>Special Class Status:</u>	<u>N: Course is not a special class</u>

**Date:** September 28, 2018  
**Submitted by:** Norberto Lopez, Curriculum Technician  
**Area Administrator:** Dr. Debra Daniels, Superintendent/President  
**Subject:** Request for Approval

---

**Board Meeting Date:** October 10, 2018

**Title of Board Item:**

Program Revision

**Background:**

Under accreditation requirements, academic institutions are expected to review and update its curriculum to ensure they meet current standards.

**Math & Science Division**

The Liberal Arts Area of Emphasis: Math and Science degree requires 18 units of math courses. This revision reflects the new MATH 1510 course as well as the previously approved MATH 1505 and BIOL 2265 courses.

1. Liberal Arts Area of Emphasis: Math and Science

**Expense (if applicable):**

None

**Fiscal Impact Including Source of Funds (if applicable):**

None

**Approved:**   
\_\_\_\_\_  
Dr. Debra Daniels, Superintendent/President

**A.A. Liberal Arts Area of Emphasis: Math and Science**

Requirements	Dept. Name/#	Name	Units	CSU -GE	IGETC	Sequence
Required Core Select 18 units from the following:	MATH 1500	Math for a Modern Society—A Liberal Arts Course	4	B4	Area 2	Yr 1, Spr
	<b>MATH 1505</b>	<b>Mathematical Concepts for Elementary Teachers</b>	<b>4</b>			
	<b>MATH 1510</b>	<b>College Algebra for Liberal Arts</b>	<b>4</b>			
	MATH 1520	Finite Mathematics	3	B4	Area 2	Yr 1 Spr
	MATH 1530	Plane Trigonometry	4	B4		Yr 1 Fall
	MATH 1540	Precalculus Mathematics	4	B4	Area 2	Yr1 Spr
	MATH 2100	Analytical Geometry and Calculus I	5	B4	Area 2	Yr 1 Spr
	MATH 2120	Analytical Geometry and Calculus II	4			Yr 2 Fall
	MATH 2130	Analytical Geometry and Calculus III	4			Yr 2 Spr
	MATH 2140	Ordinary Differential Equations	4			Yr 2 Spr
	STAT 1510	Elementary Statistics	5	B4	Area 2	Yr 2 Fall
Select a minimum of one course from the following:	ASTR 1511	Introduction to Astronomy with Lab	4	B1	Area 5	
	BIOL 1500	Fundamentals of Biology	3	B2	Area 5	
		<b>OR</b>				
	BIOL 1510	Fundamentals of Biology with Lab	4			
	BIOL 1513	Introduction to Environmental Studies with Lab	4	B2	Area 5	
	BIOL 2201	Introductory Biology - Cells	4	B2	Area 5	
	BIOL 2202	General Zoology	5	B2	Area 5	
	BIOL 2203	General Botany	4	B2	Area 5	
	BIOL 2250	Human Anatomy	5	B2	Area 5	
	BIOL 2257	Human Physiology with Laboratory	5			
	BIOL 2260	General Microbiology	5	B2	Area 5	
	<b>BIOL 2265</b>	<b>Human Pathophysiology</b>	<b>3</b>			
	BIOL 2370	Basic Nutrition	3			
	CHEM 1510	Introductory College Chemistry	4	B3	Area 5	
	CHEM 1520	Introductory to Organic and Biochemistry	4			
	CHEM 2211	General Chemistry	5	B1	Area 5	
	CHEM 2212	General Chemistry and Qualitative Analysis	5			
	ESCI 1520	Introduction to Earth Science Lecture and Lab	4	B3	Area 5	
	GEOG 1510	Physical Geography	3	B1	Area 5	
	GEOL 1500	Introduction to Geology	4	B1	Area 5	
	GEOL 1501	Historical Geology	4	B1	Area 5	
	PHYS 2221	General Physics (Calculus)	4	B1	Area 5	
	PHYS 2222	General Physics II (Calculus)	4		Area 5	
	PHYS 2223	General Physics III (Calculus)	4			
	PSCI 1520	Introduction to Physical Science Lecture and Lab	4	B3	Area 5	

Required Major Units: 18  
Local Transfer Pattern: 25  
Electives: 17  
Total: 60

**Date:** October 3, 2018  
**Submitted by:** Dr. Debra Daniels, Superintendent/President  
**Area Administrator:** Dr. Debra Daniels, Superintendent/President  
**Subject:** Request for Approval

---

**Board Meeting Date:** October 10, 2018

**Title of Board Item:**

Amendment 01 to the Resolution Authorizing Agreement with the California Department of Education Migrant Specialized Services Program

**Background:**

The attached amendment to contract number CMSS-8005 with the State of California Migrant Special Services program increases the Maximum Reimbursable Amount (MRA) from \$90,494 to \$98,159 for an increase of \$7,665.

**Terms (if applicable):**

July 1, 2018 - June 30, 2019

**Expense (if applicable):**

N/A

**Fiscal Impact Including Source of Funds (if applicable):**

The new MRA is \$98,159.

**Approved:**   
\_\_\_\_\_  
Dr. Debra Daniels, Superintendent/President



CALIFORNIA DEPARTMENT OF EDUCATION

1430 N Street

Sacramento, CA 95814-5901

F.Y. 18 - 19

Amendment 01

DATE: July 01, 2018

CONTRACT NUMBER: CMSS-8005

PROGRAM TYPE: MIGRANT SPECIALIZED SERVICES

PROJECT NUMBER: 15-6386-00-8

LOCAL AGREEMENT FOR CHILD DEVELOPMENT SERVICES

Budget Act

CONTRACTOR'S NAME: WEST KERN COMMUNITY COLLEGE DISTRICT

This agreement with the State of California dated July 01, 2018 designated as number CMSS-8005 shall be amended in the following particulars but no others:

The Maximum Reimbursable Amount (MRA) payable pursuant to the provisions of this agreement shall be amended by deleting reference to \$90,494.00 and inserting \$98,159.00 in place thereof.

EXCEPT AS AMENDED HEREIN all terms and conditions of the original agreement shall remain unchanged and in full force and effect.

STATE OF CALIFORNIA		CONTRACTOR				
BY (AUTHORIZED SIGNATURE)		BY (AUTHORIZED SIGNATURE)				
PRINTED NAME OF PERSON SIGNING Jaymi Brown,		PRINTED NAME AND TITLE OF PERSON SIGNING Dr. Debra Daniels, Superintendent/President				
TITLE Contract Manager		ADDRESS 29 Cougar Ct. Taft, CA 93268				
AMOUNT ENCUMBERED BY THIS DOCUMENT \$ 7,665	PROGRAM/CATEGORY (CODE AND TITLE) Child Development Programs	FUND TITLE General		Department of General Services use only		
PRIOR AMOUNT ENCUMBERED FOR THIS CONTRACT \$ 90,494	(OPTIONAL USE) 0656 23360-6386					
TOTAL AMOUNT ENCUMBERED TO DATE \$ 98,159	ITEM 30.10.020.004 6100-194-0001	CHAPTER B/A	STATUTE 2018			FISCAL YEAR 2018-2019
	OBJECT OF EXPENDITURE (CODE AND TITLE) 702 SACS: Res-6070 Rev-8530					
I hereby certify upon my own personal knowledge that budgeted funds are available for the period and purpose of the expenditure stated above.		T.B.A. NO.	B.R. NO.			
SIGNATURE OF ACCOUNTING OFFICER		DATE				



**Date:** October 3, 2018  
**Submitted by:** Dr. Debra Daniels, Superintendent/President  
**Area Administrator:** Dr. Debra Daniels, Superintendent/President  
**Subject:** Request for Approval

---

**Board Meeting Date:** October 10, 2018

**Title of Board Item:**

Amendment 01 to the Resolution Authorizing Agreement with the California Department of Education Migrant Child Care Program

**Background:**

The attached amendment to contract number CMIG-8005 with the State of California Migrant Child Care program increases the Maximum Reimbursable Amount (MRA) from \$608,440.00 to \$706,772 for an increase of \$98,332. In addition, the Maximum Rate per child day of enrollment payable increases from \$45.44 to \$47.98 for an increase of \$2.54, and the minimum Child Days of Enrollment (CDE) requirement changed from 13,390 to 14,731.

**Terms (if applicable):**

July 1, 2018 - June 30, 2019

**Expense (if applicable):**

N/A

**Fiscal Impact Including Source of Funds (if applicable):**

The new MRA is \$706,772.

**Approved:**   
\_\_\_\_\_  
Dr. Debra Daniels, Superintendent/President



**CALIFORNIA DEPARTMENT OF EDUCATION**

1430 N Street

Sacramento, CA 95814-5901

**F.Y. 18 - 19**

**Amendment 01**

DATE: July 01, 2018

**LOCAL AGREEMENT FOR CHILD DEVELOPMENT SERVICES**

Budget Act

CONTRACT NUMBER: CMIG-8005

PROGRAM TYPE: MIGRANT CHILD CARE

PROJECT NUMBER: 15-6386-00-8

CONTRACTOR'S NAME: WEST KERN COMMUNITY COLLEGE DISTRICT

This agreement with the State of California dated July 01, 2018 designated as number CMIG-8005 shall be amended in the following particulars but no others:

The Maximum Reimbursable Amount (MRA) payable pursuant to the provisions of this agreement shall be amended by deleting reference to \$608,440.00 and inserting \$706,772.00 in place thereof.

The Maximum Rate per child day of enrollment payable pursuant to the provisions of the agreement shall be amended by deleting reference to \$45.44 and inserting \$47.98 in place thereof.

**SERVICE REQUIREMENTS**

The minimum Child Days of Enrollment (CDE) Requirement shall be amended by deleting reference to 13,390.0 and inserting 14,731.0 in place thereof.

Minimum Days of Operation (MDO) Requirement shall be 263. (No Change)

EXCEPT AS AMENDED HEREIN all terms and conditions of the original agreement shall remain unchanged and in full force and effect.

STATE OF CALIFORNIA		CONTRACTOR				
BY (AUTHORIZED SIGNATURE)		BY (AUTHORIZED SIGNATURE)				
PRINTED NAME OF PERSON SIGNING Jaymi Brown,		PRINTED NAME AND TITLE OF PERSON SIGNING Dr. Debra Daniels, Superintendent / President				
TITLE Contract Manager		ADDRESS 29 Cougar Ct. Taft, CA 93268				
AMOUNT ENCUMBERED BY THIS DOCUMENT \$ 98,332	PROGRAM/CATEGORY (CODE AND TITLE) Child Development Programs	FUND TITLE General		Department of General Services use only		
PRIOR AMOUNT ENCUMBERED FOR THIS CONTRACT \$ 608,440	(OPTIONAL USE) 0656 23036-6386					
TOTAL AMOUNT ENCUMBERED TO DATE \$ 706,772	ITEM 30.10.020.004 6100-194-0001	CHAPTER B/A	STATUTE 2018			FISCAL YEAR 2018-2019
OBJECT OF EXPENDITURE (CODE AND TITLE) 702 SACS: Res-6065 Rev-8530						
I hereby certify upon my own personal knowledge that budgeted funds are available for the period and purpose of the expenditure stated above.		T.B.A. NO.	B.R. NO.			
SIGNATURE OF ACCOUNTING OFFICER		DATE				

**Date:** September 26, 2018

**Submitted by:** Andrew Prestage, Executive Director Information Technology *AP*

**Area Administrator:** Dr. Debra Daniels, Superintendent/President

**Subject:** Request for Ratification

---

**Board Meeting Date:** October 10, 2018

**Title of Board Item:**

Strata Information Services quote for IT Programming Support

**Background:**

This agreement provides Taft College with access to contract personnel who have highly technical programming support skills. These services (not to exceed 240 hours) are requested for no more than 20 hours a week for up to 12 weeks to ensure business continuity of our Banner system until the Programmer II position has been filled.

**Terms (if applicable):**

Extension of current agreement for professional services, which originated in 2009 to 2019.

**Expense (if applicable):**

Hourly cost remains at \$170.00 per hour. However, SIG has the opportunity to adjust once every year by no more than \$5.00 per hour.

**Fiscal Impact Including Source of Funds (if applicable):**

Anticipate utilizing SIG services for the estimated cost range of \$30,600 - \$40,800. This item is budgeted annually in the IT budget using General Revenue Funds.

**Approved:**   
\_\_\_\_\_  
Dr. Debra Daniels, Superintendent/President



**Strata Information Group  
Statement of Work  
(TAFTCOLLEGE-SOW110-PROGRAMMINGSSUPPORT)  
September 26, 2018**

<b>Taft College</b>	<b>Banner® Programming Services</b>
---------------------	-------------------------------------

Under the terms of the Agreement dated January 5, 2009 and further amended July 1, 2016, Strata Information Group (SIG) will provide consulting services for the staff of Taft College (Taft) as directed, to perform the following work.

**Description of Work:**

Taft has requested Banner® programming and technical consulting services from SIG. The proposed schedule is 20 hours per week for 9 - 12 weeks.

**Proposed Services:**

Tasks	Hours
Functional and technical consulting	180 - 240
<b>Total Hours Range:</b>	<b>180 - 240</b>

**Summary of Estimated Costs:**

Labor Range:	Travel Expenses:	Total Cost Range:
\$30,600 - \$40,800	\$0 (remote services)	\$30,600 - \$40,800

**Notes:**

- Rate: \$170/hour for on-site and remote delivered services through June 30, 2019; rates may increase by \$5/hour effective July 1, 2019, and on each subsequent year.
- SIG will invoice only for the consulting hours and travel expenses actually used.
- The hours estimate includes project management, preparation time, remote labor, and the development of trip reports.
- Approximate hours and costs are based on the estimated tasks to complete this project. This may vary based on the assumptions listed and changes in Taft’s needs.
- Travel expenses, if applicable:
  - Travel time is capped at 8 hours per trip.
  - Travel expenses are estimated at \$1,700 per consultant, per trip.
  - SIG will make every attempt to reduce travel costs, including coach airfares and the use of the client’s recommended lodging.
  - Actual travel expenses may be lower or higher than estimated. Labor costs may be adjusted to accommodate this as long as the total cost is not exceeded.
- Costs exclude all state taxes, if applicable.
- SIG will invoice for meals and incidental expenses on a per diem basis. Receipts will not be provided. Per diem rates are generally based on GSA guidelines. Per diem rates are: \$59 per full on-site day \$44.25 per partial day

For Taft College:

For Strata Information Group:

  
 \_\_\_\_\_  
 Dr. Debra Daniels Date  
 President/Superintendent

DocuSigned by:  
  
 \_\_\_\_\_  
 Henry A. Eimstad Date  
 President Sep-26-2018

## **General Outline of Services**

These services are subject to change depending on Taft's priorities, needs, and availability of staff and systems.

### **SIG assumptions and access requirements to be provided by Taft, as applicable:**

- Provide a designated, single point of contact for SIG staff to coordinate planning and logistical needs
- Provide secure remote access to all required systems, software tools, or applications as required with the most current data available for SIG staff access
- Assist with installation and configuration of necessary hardware and software agreed upon prior to SIG beginning its work
- Provide existing documentation as determined in initial conference calls
- Provide access to IT staff, key functional users, or other staff as needed in a timely manner throughout the engagement
- Provide timely technical support to the SIG consultant(s) when needed; SIG's ability to perform requires timely support from the Taft staff
- Advise SIG of vacations, holidays, hardware maintenance, planned power outages, or other scheduled activities that would impact delivery of service

**Date:** September 12, 2018  
**Submitted by:** Dr. Debra Daniels, Superintendent/President  
**Area Administrator:** Dr. Debra Daniels, Superintendent/President  
**Subject:** Request for Ratification

---

**Board Meeting Date:** October 10, 2018

**Title of Board Item:**

Independent Contractor Agreement with Jamie Smith, The Internal Potential, for Evaluation of the Child Care Center

**Background:**

I am recommending the approval to contract Jamie Smith of The Internal Project to conduct an evaluation of the Child Care Center and program. The evaluation will include a full program tour, interviews with staff, and full program fiscal audit.

**Terms (if applicable):**

July 1, 2018 through August 30, 2018

**Expense (if applicable):**

\$120.00 per Hour and Travel Expenses (Total Payment Not to Exceed \$14,400.00)

**Fiscal Impact Including Source of Funds (if applicable):**

Expense Covered by District funds

**Approved:**   
Dr. Debra Daniels, Superintendent/President

**WEST KERN COMMUNITY COLLEGE DISTRICT  
CONTRACT FOR PROFESSIONAL SERVICES**

This agreement is entered into by and between the WEST KERN COMMUNITY COLLEGE DISTRICT ("District") and Jamie Smith of The Internal Potential ("Consultant"). The agreement is effective upon execution.

**Recitals**

1. District desires to obtain the services of an education consultant especially trained and experienced in rendering the following services: Duties of a Child Care Center Program Evaluator (and as may be more particularly described in paragraph 3 of terms below).
2. Consultant is an Independent Contractor especially trained and experienced in providing the services described in recital #1 above.
3. The parties have agreed that the Consultant will provide a third-party independent evaluation of the Taft College Child Development Center as specified in this Agreement as an Consultant, as available, and not as an employee of the District.

**Terms**

NOW, THEREFORE, THE PARTIES AGREE AS FOLLOWS:

1. **Recitals Approved.** The above recitals are true and correct.
2. **Length of Agreement.** Consultant shall provide the services commencing July 1, 2018 through August 30, 2018.
3. **Services to be Provided.** The services to be provided to the District by the Consultant include but are not necessarily limited to the following: evaluation of curriculum, facilities, teaching ratios, and budget. The audit will include a full program tour, interviews with staff, and a full program fiscal audit. The details are outlined in Appendix A.
4. **Compensation.** Consultant shall be paid the sum of \$120.00/hr for approximately 80-100 hours of on-site and remote work. An invoice will be submitted electronically at the end of every month. The District will reimburse Consultant travel costs. The Consultant bills at the ½ time FTE rate during travel. It is estimated that 4-6 site visits would be needed to effectively capture the data. Consultant's starting location is 706 Canoas Creek Circle, San Jose, CA 95136. Payment will not exceed \$14,400.00.
5. **Hold Harmless Agreement.** Any amounts paid under this Agreement constitute

the total compensation for all services rendered by Consultant. The Consultant agrees to pay all Social Security and other income taxes which may accrue by reason of this Agreement, and to indemnify, defend, and hold the District, its officers, agents, and employees harmless from all claims, penalties, damages, liabilities, costs, and expenses including attorney fees, related to Consultant's failure to pay these and similar obligations. Further, since Consultant is acting solely in a Consultant capacity, the Consultant and its staff will not be entitled to and shall not by reason of this Consultant arrangement receive any employee benefits from the District.

6. **Monthly Service Report.** Upon request, Consultant shall submit a monthly service report in writing to the District, which shall include a diary showing days and service rendered.

7. **Standards of Ethical Conduct and Confidentiality.** Standards of ethical conduct and confidentiality shall be maintained, and Consultant will not engage in inappropriate contacts or professional conflicts of interest.

8. **Earlier Termination.** District may terminate this Agreement upon providing Consultant with 15 days' prior written notice of such termination.

Executed at Taft, California, on the dates shown below.

Date of WKCCD Board Approval:

\_\_\_\_\_

West Kern Community College District:

Consultant:

By: Dr. Debra S. Daniels

By: Jamie Smith, The Internal Potential

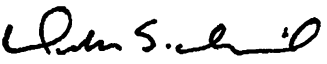
  
\_\_\_\_\_  
Signature

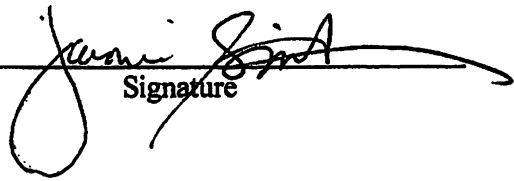
  
\_\_\_\_\_  
Signature

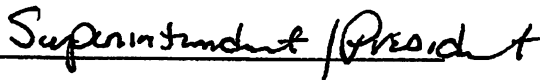
  
\_\_\_\_\_  
Title





The  
Internal  
Potential

706 Canoas Creek Circle  
San Jose, CA 95136  
831-915-0010  
www.theinternalpotential.com

## Taft College Child Development Center

### Program Evaluation Proposal

June 8, 2018

A third-party independent evaluation of Taft College's Child Development Center (CDC) has been requested to gain insight into four areas of program and administrative management. These areas with their guiding questions are as follows:

1. **Curriculum:** Is the curriculum design and implementation process at the CDC happening in a DAP manner? What type of curriculum is being used based on program philosophy? What learning opportunities occur to provide staff with outlets to obtain current field-related knowledge?
2. **Facilities:** Are the CDC facilities adequate for its type of program?
3. **Teaching ratios and staffing:** Is the CDC staffing being maximized and being used in the most efficient and effective way possible?
4. **Budget:** Is the CDC program budget fiscally sound? Are there hidden opportunities that if found and acted upon, could strengthen the program, financially?

An evaluation report will include findings, and analytical considerations and recommendations for the four above evaluated areas and will be given to the client at the project's completion. In order to create an objective evaluation, there are eight modes of quantitative and qualitative information gathering that has been identified. Other areas not identified in the eight areas below may emerge during the evaluation process to support the project. The below areas are in rough order of tasks to complete:

1. **Conduct a full program tour** with the Director with a Q/A session after the tour.
2. **Observe each indoor and outdoor classroom environment.** Observables may include (but not limited to) environment set-up and materials offered, curriculum planning and delivery methods (teaching style), discipline techniques and behavior plan protocols, social-emotional supports, health and safety measures, meal service, family partnership elements, and relationships between all members of staff. Video recordings may be used for a portion of the observations.
3. **Review the 2015-2017 QRIS report**, which should include the ERS and CLASS assessments.
4. **Review coaching cycles and coaching plans** from the 2015-17 QRIS and all other items that the director and teachers are currently being coached on.
5. **Conduct an in-depth PAS** on the whole program. The Program Administration Scale (PAS) is a valid and reliable instrument designed to measure the leadership and management practices of early childhood programs. The PAS provides valuable information to directors about the quality of their administrative practices and can be used as a springboard for program improvement efforts.

The PAS measures quality on a 7-point scale in 25 items clustered in 10 subscales:

- Human Resources Development
- Personnel Cost and Allocation
- Center Operations

- Child Assessment
  - Fiscal Management
  - Program Planning and Evaluation
  - Family Partnerships
  - Marketing and Public Relations
  - Technology
  - Staff Qualifications
6. Interview the Director, the 2<sup>nd</sup> in-charge admin, as well as a member from each classroom. The interviews are meant to capture information pertaining to (but not limited to) all aspects of the curriculum, professional philosophy, relationships, planning time, staffing schedule, and time management. *An interview with the Child Development Department Chair will be requested, since lab students are utilized as part of the CDC's staff.*
  7. Full program fiscal audit to lead to a summary of suggested cost-effective business practices and/or identified areas that are in need of more financial support.

**Timeline**

Work to commence immediately, upon signed contract. The project would be completed by August 30, 2018

**Hourly rate**

This project is expected to be approximately 80-100 hours of on-site and remote work. The consultant's rate is \$120/hr and is invoiced electronically at the end of every month to the client.

**Travel costs**

Client would reimburse consultant for travel costs.

The consultant bills at the ½ time FTE rate during travel.

It is estimated that 4-6 site visits would be needed to effectively capture the data. Consultant's starting location is 706 Canoas Creek Circle San Jose, CA 95136

**Total contract not to exceed \$14,000.00**

Thank you for your consideration to provide Taft Community College with professional services that will be used to improve the quality of the Child Development Center and I look forward to our continued dialog!

Cheers,



Jamie Smith, MA MS  
Founder | Consultant

**Date:** October 3, 2018  
**Submitted by:** Brock McMurray, EVP of Administrative Services *Bm*  
**Area Administrator:** Brock McMurray, EVP of Administrative Services  
**Subject:** Request for Ratification

---

**Board Meeting Date:** October 10, 2018

**Title of Board Item:**

Request for Ratification of Agreement with BSK Associates

**Background:**

This is an agreement for construction materials testing and inspection services in connection with the current scoreboards replacement project. These services are required in order to satisfy Division of State Architect requirements.

The scope of services for this agreement includes drilled pier inspection, concrete batch plant inspection, concrete sampling, concrete sample pickup, steel shop material identification, field welding inspection, laboratory testing, and report preparation. The total cost estimate for these services is \$5,441.00, and will be paid for using district general funds allocated for Annual Program Review items.

**Terms (if applicable):**

Please see attached agreement with BSK Associates.

**Expense (if applicable):**

\$5,441.00

**Fiscal Impact Including Source of Funds (if applicable):**

These services will be paid for using district general funds allocated for Annual Program Review items.

**Approved:** \_\_\_\_\_

*Debra Daniels*  
Dr. Debra Daniels, Superintendent/President



700 22<sup>nd</sup> Street  
Bakersfield CA 93301  
P 661.327.0671  
F 661.324.4218  
www.bskassociates.com

VIA EMAIL: [jvargas@aparchitects.net](mailto:jvargas@aparchitects.net)

October 3, 2018

BSK Proposal CB18-17200

West Kern Community College District  
c/o AP Architects  
Mr. Jose Vargas, A.I.A.  
3434 Truxtun Avenue, Suite 240  
Bakersfield, California 93301

**SUBJECT:       REVISED Proposal for Construction Materials Testing and Inspection Services  
                  WKCCD – Baseball and Softball Scoreboard  
                  29 Emmons Park Drive  
                  Taft, California 93268**

Dear Mr. Vargas;

We are pleased to submit this REVISED proposal to provide Construction Materials Testing and Inspection Services for the WKCCD – Baseball and Softball Scoreboard project in Taft, California.

**SCOPE OF SERVICES**

Our scope of services for this project includes drilled pier inspection, concrete batch plant inspection, concrete sampling, concrete sample pickup, steel shop material identification, field welding inspection, laboratory testing, and report preparation.

Our scope of services does not include shop welding inspection. If you should need those services we have excluded, please contact our office, so we can amend this REVISED proposal.

**FEES**

We will charge our services on a time-and-materials basis in accordance with the hourly rates listed in our *Cost Estimate* for this prevailing wage project. The hours and units listed in our *Cost Estimate* are only estimates. We cannot account for delays of which we have no control such as, but not limited to, retest and reinspections, contractor's schedule, contractor's means and methods, or number of workers on contractor's crew. We will separate retests, reinspections, standby, cancellations, and other delays which increases our time on the project beyond what we estimated. We will bill travel time "portal-to-portal" from our Bakersfield office. We will bill in one-hour increments including travel. We will submit invoices on a monthly basis with work completed during the invoice period. To accommodate the construction schedule, we may need to employ subcontract special inspectors. Should we need to employ subcontract special inspectors, we will bill their time on our invoices and charge their time as if they are BSK employees in accordance with our rates listed in our *Cost Estimate*. Tests and inspections not included in our scope of services above will be charged in accordance with our *2018 Schedule of Fees*.

Cost Estimate

FIELD SERVICES	TRIPS	HRS/TRIP	HOURS	RATE	COST
<b>Earthwork Construction</b>					
Drilled Pier Foundation Observation	1	4	4	\$113	\$452
<b>Concrete Construction</b>					
Concrete Batch Plant Inspection	1	4	4	\$113	\$452
Concrete Sampling	1	6	6	\$113	\$678
Concrete Sample Pick Up	1	2	2	\$113	\$226
<b>Steel Construction</b>					
Local Shop Material ID	1	4	4	\$125	\$500
Field Welding Inspection	1	8	8	\$125	\$1,000
<b>Unit Charges</b>					
Mileage (round trip 75 miles)	6	MILES/TRIP 75	MILES 450	\$0.88	\$396
<b>FIELD SERVICES ESTIMATE</b>					<b>\$3,704</b>
<b>LABORATORY TESTING</b>					
	FREQUENCY		SETS/UNITS	RATE	COST
Concrete Compressive Strength (per standard sample)	1 per 50 cubic yards		1	\$130	\$130
Steel Rebar - Bend and Tensile (per sample)	1 per heat/size		4	\$142	\$568
<b>LABORATORY TESTING ESTIMATE</b>					<b>\$698</b>
<b>OFFICE WORK</b>					
			HOURS	RATE	COST
Project Administration (7% of field and laboratory charges)				7%	\$308
Certified Payroll Administration for DIR Compliance				3%	\$111
Project Management by Project Manager			2	\$140	\$280
Report Review by Engineer			2	\$170	\$340
<b>OFFICE WORK ESTIMATE</b>					<b>\$1,039</b>
<b>TOTAL ESTIMATE</b>					<b>\$5,441</b>

We based our Cost Estimate on the following assumptions:

- field work will occur during normal business hours Monday through Friday;
- a standard work day is 8 hours per day, Monday through Friday including travel time. We will charge 1.5 times the standard hourly rate for working from 8 to 12 hours in one day; beyond 12 hours is double time;
- shops and batch plants are local to Bakersfield;
- welding inspection will be at a single shop for a single shift; and
- the contractor, shop, or client will provide safe and adequate access to perform testing and inspection.

We will notify you if it appears that the amount of time we spend working on the project may exceed our total budget estimate. However, due to the timing and nature of our services, this may not always be possible. We will make every effort to respond to your inspection needs on this project. To assure we provide the services you need, we request that you, or your authorized representative schedule inspection and testing services at least 48 hours in advance. To avoid show-up charges, please cancel requests for service at least two working hours in advance of our arrival time.

**GENERAL CONDITIONS AND LIMITATIONS**

We have included a copy of the *Agreement for Construction Materials Testing Services* with this proposal and our *General Conditions for Construction Materials Engineering and Testing Services*.

We provide material testing and inspection services to help ensure that the work is in substantial conformance with the project documents and as required by applicable jurisdictions. These services shall not be construed as acceptance of the work or relieve the contractor in any way from its obligations and responsibilities as outlined in the applicable construction documents. We assume no responsibility for the safety of others on the jobsite or the means and methods of construction.

We will perform our services consistent with that level of care and skill ordinarily exercised by other consultants practicing in the same discipline and locale at the time the services are performed. No other warranties, either



express or implied are provided. If changes occur in the design of the project, please notify us in writing.

Our *cost estimate* and associated rates are subject to change if our proposal is not accepted in writing with in three months of proposal date.

**AUTHORIZATION**

If our REVISED proposal and general conditions are acceptable, please sign our agreement and return to us. We will countersign the agreement and return a copy to you.

We appreciate the opportunity to work with you on this project. If you have questions, please call us at (661) 327-0671.

Sincerely,  
BSK Associates

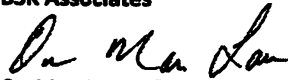
  
On Man Lau, P.E., G.E.  
South Valley Regional Manager  
California Geotechnical Engineer #2644

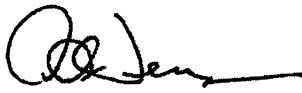
  
Adam Terronez, P.E., G.E.  
Bakersfield Branch Manager  
California Geotechnical Engineer #2709

Enclosures: *Agreement for Construction and Materials Testing Services*  
*General Conditions for Construction and Materials Testing Services*

NR/nr



## AGREEMENT FOR CONSTRUCTION MATERIALS ENGINEERING AND TESTING SERVICES

THIS AGREEMENT, effective as of this 3rd day of October 2018, is by and between West Kern Community College District ("Client") and BSK Associates ("Consultant").

THE PROJECT is generally described as WKCCD – Baseball and Softball Scoreboard.

THIS AGREEMENT consists of the following documents which are incorporated herein by reference:

- General Conditions for Construction and Materials Testing Services;
- Consultant's Scope of Services presented in BSK's REVISED proposal CB18-17200, dated October 3, 2018.

Consultant agrees to perform the Services set forth in this Agreement and in accordance with its terms, including all attachments incorporated herein by reference. This Agreement may not be modified or altered, except in writing as specifically described in this Agreement.

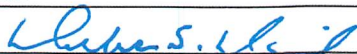
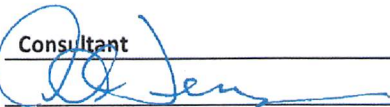
	Client	Consultant
Signature:	<u></u>	<u></u>
Print Name:	<u>Debra S. Daniels</u>	<u>Adam Terronez</u>
Title:	<u>Superintendent/President</u>	<u>Bakersfield Branch Manager</u>
Company:	<u>West Kern Comm. College District</u>	<u>BSK Associates</u>
Address:	<u>29 Cougar Ct.</u> <u>Taft CA 93268</u>	<u>700 22<sup>nd</sup> Street</u> <u>Bakersfield, California 93301</u>
Date:	<u>10-3-18</u>	<u>10/3/18</u>



# GENERAL CONDITIONS FOR CONSTRUCTION MATERIALS ENGINEERING & TESTING SERVICES

## 1. DEFINITIONS

**1.1 Contractor.** The contractor or contractors, and including its/their subcontractors of every tier, retained to perform construction Work on the Project for which Company is providing Services under this Agreement.

**1.2 Day(s).** Calendar day(s) unless otherwise stated.

**1.3 Hazardous Materials.** Any toxic substances, chemicals, radioactivity, pollutants or other materials, in whatever form or state, known or suspected to impair the environment in any way whatsoever. Hazardous Materials include, but are not limited to, those substances defined, designated or listed in any federal, state or local law, regulation or ordinance concerning hazardous wastes, toxic substances or pollution.

**1.4 Inspection (or Observation).** Visual determination of conformance with specific or, on the basis of Company's professional judgment, general requirements.

**1.5 Services.** The professional services provided by Company under this Agreement, including all services described in the SCOPE OF SERVICES included in Exhibit A, and any written Task Order or amendment to this Agreement.

**1.6 Testing.** Measurement, examination, performance of tests, and any other activities to determine the characteristics or performance of materials.

**1.7 Work.** The labor, materials, equipment and services of Contractor.

## 2. SCOPE OF SERVICES

**2.1 Services Provided; Independent Contractor.** Company will provide construction materials engineering and testing services as set forth in the SCOPE OF SERVICES in Exhibit A. Company will perform its Services under this Agreement as an independent contractor.

**2.2 Authority of Company.** Company will report observations and data to the Client. Company will report any observed work to the Client or Client's representative, which, in Company's opinion, does not conform with plans, specifications, and codes applicable to the Project. Company has no right or responsibility to approve, accept, reject, or stop work of any agent of the Client.

**2.3 Referenced Standards.** Company will perform all standard tests, inspections and observations in general accordance with referenced standards and makes no representation regarding compliance with any other standards.

**2.4 Variation of Material Characteristics and Conditions.** Observations and standardized sampling, inspection and testing procedures employed by Company will indicate conditions of materials and construction activities only at the precise location and time where and when Services were performed.

Client recognizes that conditions of materials and construction activities at other locations may vary from those measured or observed, and that conditions at one location and time do not necessarily indicate the conditions of apparently identical material(s) at other locations and times. Services of Company, even if performed on a continuous basis, should not be interpreted to mean that Company is observing, verifying, testing or inspecting all materials on the Project. Company is responsible only for those data, interpretations, and recommendations regarding the actual materials and construction activities observed, sampled, inspected or tested, and is not responsible for other parties' interpretations or use of the information developed. Company may make certain inferences based upon the information derived from these procedures to formulate professional opinions regarding conditions in other areas.

**2.5 Changes in Scope.** Client may request changes in the SCOPE OF SERVICES in Exhibit A. Such changes, including any change in Company's compensation or time of performance, which are mutually agreed upon by Company and Client, will be incorporated in written amendments to this Agreement. No change will be effective unless it is in writing and signed by Client and Company, or if made orally, confirmed by the parties in writing within 10 days.

**2.6 Excluded Services.** Company's Services under this Agreement include only those Services specified in the SCOPE OF SERVICES in Exhibit A. Client expressly releases any claim against Company relating to any additional Services that Company recommended, but that Client either did not authorize or instructed Company not to perform.

## 3. PAYMENTS TO COMPANY

**3.1 Basic Services.** Company will perform all Services set forth in the SCOPE OF SERVICES AND SCHEDULE OF CHARGES for the amount(s) set forth therein. Company will give Client at least 30 days advance notice of any changes to its standard rates. Unless Client objects in writing to the amended fee structure within 30 days of notification, it will be incorporated into this Agreement and will supersede any prior fee structure.

**3.2 Additional Services.** Any Services performed under this Agreement, except those Services expressly identified otherwise in the attached SCOPE OF SERVICES in Exhibit A, will be provided on a time and materials basis unless otherwise specifically agreed to in writing by both parties.

**3.3 Estimate of Fees.** Company will, to the best of its ability, perform the Services and accomplish the objectives defined in this Agreement within any written cost estimate provided by Company. Client recognizes that unforeseen circumstances along with changes in scope and schedule can influence the successful completion of Services within the estimated cost. The use of an estimate of fees or of a "not to



exceed" limitation indicates that Company will not incur fees and expenses in excess of the estimate or limitation amount without obtaining Client's agreement to do so, but is not a guarantee that the Services will be completed for that amount.

**3.4 Rates.** Client will pay Company at the rates set forth in the SCHEDULE OF CHARGES in Exhibit A, which is subject to periodic review and amendment, as appropriate to reflect Company's then-current fee structure.

**3.5 Prevailing Wages.** Unless Client specifically informs Company in writing that prevailing wage regulations cover the Project and the SCOPE OF SERVICES in Exhibit A identifies it as covered by such regulations, Client hereby releases and agrees to reimburse Company for any liability and costs it may incur resulting from a subsequent determination that prevailing wage regulations cover the Project, including all costs, fines and attorney's fees.

**3.6 Payment Timing; Late Charge.** Company will submit invoices to Client periodically, but no more frequently than every two (2) weeks. All invoices are due and payable upon presentation, and any amounts unpaid 30 days after the invoice date will include a late payment charge from the date of the invoice, at 1-1/2% per month or the maximum legal rate, whichever is lower. The failure by Client to pay Company within thirty (30) days of date of invoice will constitute a substantial failure of Client to perform under this Agreement. Client will reimburse Company for all time spent and expenses (including fees of any attorney, collection agency, and/or court costs) incurred in connection with collecting any delinquent amount.

**3.7 Payment Disputes.** If Client objects to any portion of an invoice, Client must so notify Company in writing within 10 days of the invoice date, identify the cause of disagreement, and pay when due the portion of the invoice not in dispute. The parties will immediately make every effort to resolve the disputed portion of the invoice. Payment thereafter will first be applied to accrued interest and then to the unpaid principal amount.

#### 4. PERFORMANCE STANDARD

**4.1 Professional Standards.** Company will perform the Services consistent with that level of care and skill ordinarily exercised by other professionals providing similar services in the same locale and under similar circumstances at the time the Services are performed. No other representation, express or implied, and no warranty or guarantee is included or intended by this Agreement or any report, opinion, document, or other instrument of service.

**4.2 Sampling, Inspection & Test Locations.** Unless specifically stated otherwise, the SCOPE OF SERVICES in Exhibit A does not include surveying the Site or precisely identifying sampling, inspection or test locations, depths or elevations. Sampling, inspection and test locations, depths and elevations will be based on field estimates and information furnished by Client and its representatives. Unless stated otherwise in the report, such locations, depths and elevations are approximate. Company will take reasonable precautions to limit damage to the Project Site or Work due to the performance of Services, but Client understands that some damage may necessarily occur in the normal course of

Services, and this Agreement does not include repair of such damage unless specifically stated in the SCOPE OF SERVICES in Exhibit A.

**4.3 Sample Disposal.** Company will dispose of all samples after submission of the report covering those samples. Company will provide further storage or transfer of samples only upon Client's prior written request and agreement on appropriate compensation.

**4.4 Buried Utilities & Structures; Property Restoration.** If the Services require borings, test pits or other invasive exploratory work, Client will provide Company with all information in its possession regarding the location of underground utilities and structures. Company will contact an appropriate utility locator and take into consideration utility locations shown on drawings provided to Company by the Client to reduce the risk of damage or injury to underground structures, pipelines and utilities. The Client agrees to hold Company harmless for any damage to underground structures or utilities that are not called to its attention or are not correctly shown on plans or drawings furnished for the purpose of locating such structures and utilities. If Client desires Company to restore the property to its former condition or better, Company will provide the additional Services at an additional cost.

#### 5. CONTRACTOR'S PERFORMANCE

Company is not responsible for Contractor's means, methods, techniques or sequences during the performance of its Work. Company will not supervise or direct Contractor's Work, nor be liable for any failure of Contractor to complete its Work in accordance with the Project's plans, specifications and applicable codes, laws and regulations. Client understands and agrees that Contractor, not Company, has sole responsibility for the safety of persons and property at the Project Site.

#### 6. CLIENT'S RESPONSIBILITIES

In addition to payment for the Services performed under this Agreement, Client agrees to:

**6.1 Access.** Grant or obtain free access to the Project Site for all equipment and personnel necessary for Company to perform its Services under this Agreement.

**6.2 Representative.** Designate a representative for notices and information pertaining to the Services, communicate Client's policies and decisions, and assist as necessary in matters pertaining to the Project and this Agreement. Client may change its representative by written notice.

**6.3 Information.** Supply to Company all information and documents relevant to the Services. Company may rely upon such information without independently verifying its accuracy. Client will notify Company of any known potential or possible health or safety hazard regarding the materials to be tested, including its intended use, chemical composition, relevant MSDS, manufacturers' specifications and literature, and any previous test results.

**6.4 Project Information.** Client agrees to provide Company within 7 days after written request, a correct statement of the recorded legal title to the property on which

the Project is located and the Client and/or Owner's interest therein.

## 7. CHANGED CONDITIONS

If Company discovers conditions or circumstances that it did not contemplate ("Changed Conditions") at the time of this Agreement, it will give Client written notice of the Changed Conditions. Client and Company will then negotiate an appropriate amendment to this Agreement. If they cannot agree upon an amendment within 30 days after the notice, Company may terminate this Agreement and be compensated as set forth in Section 12, "Suspension & Delay; Termination."

## 8. CERTIFICATIONS

Client will not require Company to execute any certification regarding Services performed or Work tested or observed unless: 1) Company believes that it has performed sufficient Services to provide a sufficient basis to issue the certification; 2) Company believes that the Services performed and Work tested or observed meet the criteria of the certification; and 3) Company has reviewed and approved in writing the exact form of such certification prior to execution of this Agreement. Any certification by Company is limited to the expression of a professional opinion based upon the Services performed by Company, and does not constitute a warranty or guarantee, either express or implied. Client agrees not to condition the resolution of any dispute upon Company signing a certification.

## 9. ALLOCATION OF RISK

**9.1 Limitation of Remedy.** The total cumulative liability of Company, its subconsultants and subcontractors, and all of their respective shareholders, directors, officers, employees and agents (collectively "Company Entities") to Client arising from Services under this Agreement, including attorney's fees due under this Agreement, will not exceed the gross compensation received by Company under this Agreement or \$50,000, whichever is less. This limitation applies to all lawsuits, claims or actions that allege errors or omissions in Company's Services, whether alleged to arise in tort, contract, warranty, or other legal theory. Upon Client's written request, Company and Client may agree to increase the limitation to a greater amount in exchange for a negotiated increase in Company's fee, provided that the parties amend this Agreement in writing, as provided in Section 14.3 "Modification of This Agreement."

**9.2 Indemnification of Client.** Subject to the terms and limitations of this Agreement, Company will indemnify and hold harmless Client, its shareholders, officers, directors, employees, and agents from and against any and all claims, suits, liabilities, damages, expenses (including without limitation reasonable attorney's fees and defense costs) and other losses (collectively "Losses") to the extent caused by Company's negligence in performance of this Agreement. Company's defense obligation under this indemnity paragraph is limited to the reimbursement of reasonable defense costs to the extent of the Company's actual indemnity obligation hereunder.

**9.3 Indemnification of Company.** Client will indemnify and hold harmless Company Entities from and against any and all Losses except to the extent caused by the sole negligence of Company Entities. In addition, except to the extent caused by Company's negligence, Client will defend, indemnify and hold harmless Company Entities from and against any and all Losses arising from or related to the existence, disposal, release, discharge, treatment or transportation of Hazardous Materials, or the exposure of any person to Hazardous Materials, or the degradation of the environment due to the presence, discharge, disposal, release of or exposure to Hazardous Materials.

**9.4 No Personal Liability.** Client and Company intend that Company's Services will not subject Company's individual employees, officers or directors to any personal liability. Therefore, and notwithstanding any other provision of this Agreement, Client agrees as its sole and exclusive remedy to direct or assert any claim, demand or suit only against the business entity identified as "Company" on the first page of this Agreement.

**9.5 Consequential Damages.** Neither Client nor Company will be liable to the other for any special, consequential, incidental or penal losses or damages including but not limited to losses, damages or claims related to the unavailability of property or facilities, shutdowns or service interruptions, loss of use, profits, revenue, or inventory, or for use charges, cost of capital, or claims of the other party and/or its customers.

**9.6 Continuing Agreement.** The provisions of this Section 9, "Allocation of Risk," will survive the expiration or termination of this Agreement. If Company provides Services to Client that the parties do not confirm through execution of an amendment to this Agreement, the provisions of this Section 9 will apply to such Services as if the parties had executed an amendment.

## 10. INSURANCE

**10.1 Company's Insurance.** If reasonably available, Company will maintain the following coverages:

**10.1.1 Statutory Workers' Compensation/Employer's Liability Insurance;**

**10.1.2 Commercial General Liability Insurance with a combined single limit of \$1,000,000;**

**10.1.3 Automobile Liability Insurance, including liability for all owned, hired and non-owned vehicles with minimum limits of \$1,000,000 for bodily injury per person, \$1,000,000 property damage, and \$1,000,000 combined single limit per occurrence; and,**

**10.1.4 Professional Liability Insurance in amounts of at least \$1,000,000 per claim and annual aggregate.**

**10.2 Client's Insurance.** As appropriate, Client will obtain Builder's Risk or other property insurance to protect it from injury or damage to the Project, and which waives all rights of subrogation against Company. Proceeds from such insurance will be held by Client as trustee and will be payable to Company as its interests appear.

**10.3 Certificates of Insurance.** Upon request, Company and Client will each provide the other with certificate(s) of insurance evidencing the existence of the policies required herein. Except for Professional Liability and Workers' Compensation Insurance, all policies required under this Agreement shall contain a waiver of subrogation.

## 11. OWNERSHIP AND USE OF DOCUMENTS

**11.1 Company Documents.** Unless otherwise agreed in writing, all documents and information prepared by Company including, but not limited to, reports, boring logs, maps, field data, field notes, drawings and specifications, test data and other similar instruments of service (collectively "Documents") are the property of Company. Company has the right, in its sole discretion, to dispose of or retain the Documents.

**11.2 Client Documents.** All documents provided by Client will remain the property of Client. Company will return all such documents to Client upon request, but may retain copies for its files.

**11.3 Use of Documents.** Except as otherwise agreed to by Client and Company, all Documents prepared by Company are solely for use by Client and will not be provided by either party to any other person or entity without Company's prior written consent.

**11.3.1 Use by Client.** Client has the right to reuse the Documents for purposes reasonably connected with this Project for which the Services are provided, including without limitation design and licensing requirements of the Project.

**11.3.2 Use by Company.** Company retains the right of ownership with respect to any patentable concepts or copyrightable materials arising from Services and the right to use the Documents for any purpose.

**11.4 Electronic Media.** Company may agree at Client's request to provide Documents and information in an electronic format as a courtesy. However, the paper original issued by Company will remain the final product of the Services. Company makes no warranties, either express or implied, regarding the fitness or suitability of any electronic Documents or media.

**11.5 Unauthorized Use.** No party other than Client may rely on the Documents without Company's prior written consent and receipt of additional compensation. Client waives any and all claims against Company resulting from the unauthorized use or alteration of Documents by Client or any party obtaining them through Client. Client will defend, indemnify and hold harmless Company from and against any claim, action or proceeding brought by any party claiming to rely upon information or opinions contained in Documents without having obtained Company's prior written consent.

## 12. SUSPENSION & DELAY; TERMINATION

**12.1 Suspension & Delay.** Client may, upon 10 days written notice at any time, suspend Company's Services. Company may terminate this Agreement if Client suspends the Services for more than 60 days, in which case Client will pay Company as provided in Section 12.4. If Client suspends the Services, or

if Client or others delay Company's Services, Client and Company agree to equitably adjust the time for completion of the Services and Company's compensation for the additional labor, equipment, and other charges associated with maintaining its workforce for Client's benefit during the delay or suspension, and any charges incurred by Company for demobilization and subsequent remobilization.

**12.2 Termination for Convenience.** Company and Client may terminate this Agreement for convenience upon 10-days written notice delivered or mailed to the other party.

**12.3 Termination for Cause.** In the event of material breach of this Agreement, the non-breaching party may terminate this Agreement if the breaching party fails to cure the breach within 10 days following delivery of the non-breaching party's written notice of the breach to the breaching party. The termination notice must state the basis for the termination. The Agreement may not be terminated for cause if the breaching party cures the breach within the 10-day period.

**12.4 Payment on Termination.** Following termination other than for Company's breach of this Agreement, Client will pay Company for the Services performed prior to the termination notice date, and for any necessary Services and expenses incurred in connection with the termination of the Project, including but not limited to, the costs of completing analysis, records and reports necessary to document job status at the time of termination and costs associated with termination of subcontractor contracts in accordance with Company's then-current SCHEDULE OF CHARGES in Exhibit A.

**12.5 Force Majeure.** In the event that Company is prevented from completing performance of its obligations under this Agreement by adverse weather or other occurrence beyond the control of Company, then Company will be excused from any further performance of its obligations and undertakings. In the event of a force majeure delay that does not result in termination of the Agreement, the schedules will be equitably adjusted.

## 13. DISPUTES

**13.1 Mediation.** All disputes between Company and Client are subject to mediation. Either party may demand mediation by serving a written notice stating the essential nature of the dispute, the amount of time or money claimed, and requiring that the matter be mediated within 45 days of service of notice. No action or suit may be commenced unless the parties fail to conduct the mediation within 45 days after service of notice; or mediation occurred but did not resolve the dispute; or a statute of limitation would elapse if suit was not filed prior to 45 days after service of notice.

**13.2 Choice of Law; Venue.** This Agreement will be construed in accordance with and governed by the laws of the state in which the Project is located.

**13.3 Statutes of Limitations.** Any applicable statute of limitations will be deemed to commence running on the earlier of the date of substantial completion of Company's Services under this Agreement or the date on which claimant knew, or should have known, of facts giving rise to its claims.

#### 14. MISCELLANEOUS

**14.1 Assignment and Subcontracts.** During the term of this Agreement and following its expiration or termination for any reason, neither party may assign this Agreement or any right or claim under it, in whole or in part, without the prior written consent of the other party, except for an assignment of proceeds for financing purposes. Any assignment that fails to comply with this paragraph will be void and of no effect. Company may subcontract for the services of others without obtaining Client's consent if Company deems it necessary or desirable for others to perform certain Services.

**14.2 Integration and Severability.** This Agreement reflects the parties' entire agreement with respect to its terms and limitations and supersedes all prior agreements, written and oral. If any portion of this Agreement is found void or voidable, such portion will be deemed stricken and the Agreement reformed to as closely approximate the stricken portions as law allows. These terms and conditions survive the completion of the Services under and the termination of the Agreement, whether for cause or for convenience.

**14.3 Modification of This Agreement.** This Agreement may not be modified or altered, except by a written agreement signed by authorized representatives of both parties and referring specifically to this Agreement.

**14.4 Notices.** Any and all notices, requests, instructions, or other communications given by either party to the other must be in writing and either hand delivered to the recipient or delivered by first-class mail (postage prepaid) or express mail (billed to sender) at the addresses given in this Agreement.

**14.5 Headings.** The headings used in this Agreement are for convenience only and are not a part of this Agreement.

**14.6 Waiver.** The waiver of any term, condition or breach of this Agreement will not operate as a subsequent waiver of the same term, condition, or breach.

**14.7 Precedence.** These GENERAL CONDITIONS take precedence over any inconsistent or contradictory provisions contained in any other agreement term, proposal, purchase order, requisition, notice to proceed, or other document regarding Company's Services.

**14.8 Incorporation of Provisions Required By Law.** Each provision and clause required by law to be inserted in this Agreement is included herein, and the Agreement should be read and enforced as though each were set forth in its entirety herein.

---

*End of General Conditions*

**BOARD AGENDA ITEM**

**Date:** September 20, 2018

**Submitted by:** Severo M. Balason, Jr., Vice President of Student Services

**Area Administrator:** Dr. Debra Daniels, Superintendent/President

**Subject:** Request for Ratification



---

**Board Meeting Date:** October 10, 2018

**Title of Board Item:**

Renewal of PrestoSports for Web Design/Hosting Services (9/1/18-8/31/21)

**Background:**

Taft College would like to renew the services agreement with PrestoSports for continual site setup and hosting of the athletic website for three (3) years using the PrestoSports software. The PrestoSports software is a content management system tailored for the needs of athletic organizations. It allows staff to manage an athletic website using a simple administrative website. Also, mandated team roster, statistics, and schedule information will be mimicked on the CCCAA and athletic website of Taft College.

**Terms (if applicable):**

The term of the agreement is effective September 1, 2018 through August 31, 2021.

**Expense (if applicable):**

The estimated cost for year one (2018-2019) is \$3,350, year two (2019-2020) is \$3,450, and year three (2020-2021) is \$3,550 for a total of \$10,350 over three (3) years.

**Fiscal Impact Including Source of Funds (if applicable):**

Athletics and Vice President of Student Services funds will split (50:50) the cost for the services and have been included in the 2018-2019 budget projections.

**Approved:**   
\_\_\_\_\_  
Dr. Debra Daniels, Superintendent/President

# PRESTOSPORTS SERVICES AGREEMENT

THIS PRESTOSPORTS SERVICES AGREEMENT, together with all exhibits and any applicable addenda (collectively, the "Agreement"), is entered into on April 2, 2018, by and between PRESTOSPORTS, a division of CLUBESSENTIAL, LLC ("Licensor," "we," "us" or "our"), with its principal place of business located at 4600 McAuley Place, Ste. 350, Cincinnati, Ohio 45242, and TAFT COLLEGE ("Licensee," "you," or "your"), with its principal place of business located at 29 Cougar Court, Taft, CA 93268. The parties shall collectively be referred to herein as "the Parties."

This Agreement shall govern your purchase and ongoing use of our proprietary PrestoSports software, including all later-added features and functionalities (the "Software"), our hardware, including our Application Server (the "Application Server"), and/or any other services you receive from us under this Agreement. The Software, the Application Server, and any other services shall be collectively referred to herein as our "Services."

## 1. EFFECTIVE DATE; TERM

This Agreement will start on September 1, 2018 ("Effective Date"). The initial term of this Agreement is thirty-six (36) months (the "Initial Term"), and will start on the Effective Date and end thirty-six (36) consecutive months later. This Agreement will automatically renew for successive terms of 12 months each (each, a "Renewal Term") unless you or we provide a written notice of termination, or non-renewal, at least 60 days before the expiration of the Initial Term or any Renewal Term. The Parties may terminate this Agreement without cause, and without penalty, if such termination is by mutual written consent; otherwise, you may not cancel the Agreement without being responsible for all fees due to us through the expiration of the Initial Term, or any Renewal Term, as applicable.

## 2. ACCOUNT CONTACT INFORMATION (for billing and other notice purposes)

Taft College contact	PrestoSports contact
Kanoe Bandy <a href="mailto:kbandy@taftcollege.edu">kbandy@taftcollege.edu</a> (661) 763-7779 29 Cougar Court Taft, CA 93268	Ted Bardach, VP Business Development <a href="mailto:ted@prestosports.com">ted@prestosports.com</a> (301) 560-0803 451 Hungerford Dr., Ste. 325 Rockville, Maryland 20850

## 3. PROJECT SCOPE (redesign required)

Phase	Summary	Description
I	Planning	<ul style="list-style-type: none"> <li>▪ Introduction to PrestoSports admin system (Licensor)</li> <li>▪ Schedule design call date and time (Licensor and Licensee)</li> <li>▪ Conduct design call (Licensor and Licensee)</li> <li>▪ Review and approve design notes (Licensee)</li> <li>▪ Upload necessary images (Licensee)</li> <li>▪ DNS (Licensor and Licensee)</li> </ul>
II	Artistic Design	<ul style="list-style-type: none"> <li>▪ Default and training sites shared (Licensor)</li> <li>▪ Review of design revisions (three (3) rounds) and approval (Licensee)</li> <li>▪ For each rendition share with client new design (Licensor)</li> <li>▪ Training (Licensor and Licensee)</li> <li>▪ Data migration (Licensee)</li> </ul>
III	Website Breakdown	<ul style="list-style-type: none"> <li>▪ Continued data migration (Licensee)</li> <li>▪ Page set up for non-sport pages (Licensor)</li> <li>▪ Site breakdown and implementation of features (Licensor)</li> </ul>
IV	Review; Quality Control	<ul style="list-style-type: none"> <li>▪ Continued data migration and training (Licensee)</li> <li>▪ Register URL to search engines (Licensor)</li> <li>▪ Implement any unique features (Licensor)</li> <li>▪ QC on site (Licensor)</li> </ul>

## 4. PRESTOSPORTS DELIVERABLES

- a. Site setup and hosting of athletic website.
- b. Website graphic design, including three (3) rounds of proofs. Any additional proofs are available at no cost but may result in delays in the launch process (redesign required).
- c. Three (3) user accounts to manage the athletics website.
- d. Website accessibility outlined in Exhibit D (redesign required).
- e. Upon request from Licensee, Licensor will redesign the website for a one-time cost of \$1,500.

**5. FEES AND OTHER CHARGES**

Year 1: September 1, 2018 to August 31, 2019	
Feature	Cost
PrestoSports website hosting and standard features including but not limited to Content Management System, email marketing tool, and a custom design/responsive website	\$3,350
Live Stat viewers for all available sports	Included
<b>TOTAL</b>	<b>\$3,350</b>
Year 2: September 1, 2019 to August 31, 2020	
Feature	Cost
PrestoSports website hosting and standard features including but not limited to Content Management System, email marketing tool, and a custom design/responsive website	\$3,450
Live Stat viewers for all available sports	Included
<b>TOTAL</b>	<b>\$3,450</b>
Year 3: September 1, 2020 to August 31, 2021	
Feature	Cost
PrestoSports website hosting and standard features including but not limited to Content Management System, email marketing tool, and a custom design/responsive website	\$3,550
Live Stat viewers for all available sports	Included
<b>TOTAL</b>	<b>\$3,550</b>

**6. STORAGE AND BANDWIDTH**

Allocation for	Capacity*	Details/Notes
Application Server storage for data necessary for use of the Software	5 GB	
Bandwidth Transfer Capacity	50 GB/mo.	
Media Server for storage of video and other media files	10 GB	
Monthly transfer for video playback and podcasting	250 GB/mo.	

\* If Licensee exceeds its storage or bandwidth limit, Licensor must notify Licensee that it has exceeded the allowed storage or bandwidth limit. Licensee will have 30 days from the date of such notice to address their data size or bandwidth usage.

**7. PAYMENT TERMS**

**(a) Invoices.** You agree to pay all fees and charges specified in this Services Agreement, as amended from time to time in writing. Except as otherwise specified in the Agreement, (i) fees are quoted and payable in U.S. dollars; (ii) fees are based on Services provided, and not Licensee's actual usage; (iii) payment obligations are not cancellable except as specifically allowed under the Services Agreement or Terms of Service; (iv) fees paid are non-refundable; (v) invoices for the total contract year value will be sent 30 days in advance for each year's term start date; and (vi) invoices for one-time fees (such as site set-up or redesign) will be sent upon Service Agreement signing.

**(b) Payment Terms.** Payment is due thirty (30) days after date of invoice. You may not withhold any amounts due hereunder and we reserve the right to cease work without prejudice if amounts are not paid when due. Unpaid invoices will accrue late interest at the rate of 1.5% of the outstanding balance per month, or the maximum rate permitted by law, whichever is lower, from the date such payment was due until the date paid. If any amount owed by you under the Services Agreement, or any amendment thereto, is thirty (30) days or more overdue, we may, without limiting our other rights or remedies, accelerate any unpaid fee obligations so that all such obligations become immediately due and payable through the end of the Initial Term, and suspend your access to our Services until such amounts are paid in full.

**(c) Taxes.** Unless otherwise stated, our fees do not include taxes, levies, duties or similar governmental assessments of any nature, including but not limited to value-added, sales, use or withholdings taxes, assessable by any local, state, provincial, federal or foreign jurisdiction (collectively, "Taxes"). You are responsible for paying all Taxes associated with the Services. If we pay or collect Taxes for which you are responsible, any amounts paid by us, plus all costs and expenses incurred by us relative to such Taxes shall be invoiced to and paid by you.

**(d) Billing Errors.** You must contact us within 30 days of the invoice date of the invoice containing the amount in question to be eligible to receive and adjustment or credit. We will not exercise our rights to overdue charges or acceleration of payments if the applicable charges are under reasonable and good faith dispute, and you are cooperating diligently to resolve the dispute.

**(e) Fee Changes.** We reserve the right to change our fees and charges and introduce new charges at any time, upon at least 30 days prior notice to you, which notice may be provided by email.

**8. EXHIBITS**

The terms and conditions of the following Exhibits are expressly incorporated by reference into this Agreement:

No.	Title	Description
A	Terms of Service	States the terms and conditions under which we will provide Services to you
B	Acceptable Use Policy	Describes acceptable content for uploading to your website on our Services
C	Service Level Agreement	Describes our service level commitments to you
D	Website Accessibility Notice	Describes website accessibility standards and disclaims our liability

**ACCEPTANCE**

By its signature below, Licensee acknowledges that it has read and accepts the terms of this Services Agreement, and all Exhibits referenced above, and hereby accepts the Agreement as of the Effective Date.

**LICENSEE: TAFT COLLEGE**

  
 By: **Dr. Debra Daniels**  
 Title: **Superintendent/President**  
**West Kern Community College District**  
**LICENSOR: Clubessential, LLC**

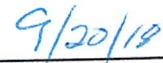
  
 Date

\_\_\_\_\_  
 By: Randy Eckels  
 Title: Chief Executive Officer

\_\_\_\_\_  
 Date



## TERMS OF SERVICE

These Terms of Service are expressly incorporated by reference into the PrestoSports Services Agreement (the "Services Agreement"). Terms not specifically defined herein shall have the meanings as set forth in the Services Agreement.

**1. GENERAL TERMS.** You accept the terms of the Agreement, as defined in the Services Agreement, either by (a) click-signing your acceptance to an online version of the Services Agreement; (b) executing a hardcopy of the Services Agreement, or (c) accepting the benefits of our Services under the Agreement. The person signing the Agreement on your behalf represents that he/she is entering into the Agreement on behalf of an organization, company, non-profit organization, or other legal entity, that such organization, company, non-profit or entity is validly existing in its state or states of operation, and that he/she has the proper legal authority to bind the Licensee to the Agreement.

**2. GRANT OF RIGHTS.** You do not own any part of the Services which belongs exclusively to us. However, by entering into this Agreement, remaining in compliance with its terms, and paying all associated fees, we grant you (and only you) a right to access and use our Services for the duration of the term. We can revoke your rights at any time, for any reason, in our sole discretion. Any rights not specifically granted to you under the Agreement are expressly reserved. Accessing or using our Services without our consent is prohibited.

### 3. USE OF OUR SERVICES.

**(a) Our Responsibilities.** We will (i) provide basic support to you at no additional charge; (ii) provide the Software in accordance with applicable laws and governmental regulations; and (iii) use commercially reasonable efforts to make our Services available 24 hours a day, 7 days a week, except for planned downtime (as defined in a Service Level Agreement); or any unavailability caused by circumstances beyond our reasonable control, including without limitation, acts of god, acts of government, floods, fire, earthquake, civil unrest, acts of terror, strikes or other labor problems (other than those involving our employees).

**(b) Your Responsibilities.** You will (i) use our Services only for your internal business operations and not for the benefit of anyone other than the Licensee identified in this Agreement; and/or (ii) use our Services in a manner that complies with all applicable laws, rules and regulations, including copyright and other intellectual property laws. You will not: (iii) re-license or sell rights to access or use the Services, or to transfer or assign rights to access or use the Services except as expressly permitted herein; (iv) modify, translate, reverse engineer, decompile or create derivative works based upon the Software; (v) transmit or share identification or password codes with unauthorized users, or permit the identification or password codes to be cached in proxy servers and accessed by individuals who are not authorized users; and/or (vi) permit access to the Software through a single identification or password code being made available to multiple users on a network.

**4. FEES.** You are responsible for timely payment of all fees and charges as more specifically described in the Services Agreement, and any validly executed amendments thereto.

**5. TERMINATION FOR CAUSE.** Either you or we may terminate this Agreement for cause upon 30 days written notice to the other party of a material breach if such breach remains uncured at the expiration of such period; or if the other party becomes the subject of a petition in bankruptcy or any other proceeding relating to insolvency, receivership, liquidation or assignment for the benefit of creditors. Upon termination for cause by you, we shall refund you any prepaid fees covering the remainder of the Initial Term, or Renewal Term (as applicable), after the effective date of termination. Upon any termination for cause by us, you shall pay any unpaid fees covering the remainder of the Initial Term, or Renewal Term (as applicable), after the effective date of termination. Termination for cause will not preclude the non-breaching party from exercise any other rights or remedies permitted by law.

### 6. OWNERSHIP RIGHTS.

**(a) What's Ours.** We reserve all rights, title and interest in and to our Services, including all related intellectual property (defined to mean all unpatented inventions, patent applications, patents, design rights, copyrights, trademarks, service marks, trade names, domain name rights, mask work rights, know-how and other trade secret rights, licenses and all other intellectual property rights, derivatives thereof, and forms of protection of a similar nature anywhere in the world). No rights are granted to you hereunder other than as expressly set forth in this Agreement. We alone shall own all rights, title and interest, including all related intellectual property, in and to our Services, and any suggestions, ideas, enhancement requests, feedback, recommendations, or other information provided by you or any other party relating to our products or services. The Agreement is not a sale and does not convey to you any rights of ownership in or related to our Services or other services, including but not limited to, the Software and Application Server.

**(b) What's Yours.** As between you and us, you will retain all rights, title and interest in and to any content created by you and posted to your site using our Services ("Your Data"). You grant to us a nonexclusive license to use, copy, store, modify and display Your Data to the extent necessary to provide our Services to you. You shall have sole responsibility for the accuracy, quality, integrity, legality, reliability, appropriateness, and intellectual property ownership or rights to use of all of Your Data, and we shall not be responsible or liable for the deletion, correction, destruction, damage, loss or failure to store any of Your Data. We reserve the right to withhold, remove and/or discard Your Data without notice for any breach, including without limitation, your non-payment of our fees. Upon termination for any reason, your right to access or use Your Data immediately ceases, and we shall have no other obligation to maintain or forward Your Data.

**7. GRANT OF MARKS.** You hereby grant us a non-exclusive, nontransferable, paid-up, worldwide license to use your marks solely in conjunction with websites and mobile applications which shall, in part, promote your products and services and which services shall reside on your website deploying our servers or such other mirror site servers as we shall approve. You reserve any and all rights not expressly and explicitly granted in the Agreement, including your right to inspect and approve our manner or use of the marks and to authorize or license use of the marks or any other trademarks to any third party for use in connection with any goods and services. We hereby acknowledge that you are the owner of the marks, we will do nothing inconsistent with such ownership and agree that all use of the marks by us shall inure to your benefit. We agree that nothing in the Agreement shall give us any right, title or interest in the marks other than the right to use the marks consistent with the Agreement. The PrestoSports name and logo are trademarks of Clubessential, LLC and no right or license is granted to use them.

**8. CONFIDENTIALITY.**

**(a) Definition of Confidential Information.** As used herein, "Confidential Information" means all confidential information disclosed by a party (the "Disclosing Party") to the other party (the "Receiving Party"), whether orally or in writing, that is designated as confidential or that reasonably should be understood to be confidential given the nature of the information and the circumstances of disclosure. Your Confidential Information shall include Your Data. Our Confidential Information shall include our Software, the Application Server, our documentation (including this Agreement and all attached exhibits), as well as business and marketing plans, technology and technical information, product plans and designs, and business processes disclosed by such party. However, Confidential Information (other than Your Data) shall not include any information that (i) is or becomes generally known to the public without breach of any obligation owed to the Disclosing Party; (ii) was known to the Receiving Party prior to its disclosure by the Disclosing Party without breach of any obligation owed to the Disclosing Party; (iii) is received from a third party without breach of any obligation owed to the Disclosing Party; or (iv) was independently developed by the Receiving Party without the breach of any obligation owed to the Disclosing Party.

**(b) Protection of Confidential Information.** Except as otherwise permitted in writing by the Disclosing Party, (i) the Receiving Party shall use the same degree of care that it uses to protect the confidentiality of its own Confidential Information of like kind (but no less than reasonable care) not to disclose or use any Confidential Information of the Disclosing Party for any purpose outside the scope of this Agreement, and (ii) the Receiving Party shall limit access to Confidential Information of the Disclosing Party to those of its employees, contractors and agents who need such access for purposes consistent with this Agreement.

**(c) Protection of Your Data.** Without limiting the above, we shall maintain appropriate administrative, physical and technical safeguards for protection of the security, confidentiality and integrity of Your Data. We shall not (i) modify Your Data; (ii) disclose Your Data except as compelled by law or as expressly permitted in writing by you; or (iii) access Your Data except to provide our services or prevent or address service or technical problems, or at your request in connection with customer support matters.

**9. WARRANTIES AND DISCLAIMERS. OUR SERVICES ARE PROVIDED "AS IS" WITHOUT WARRANTY OF ANY KIND. WE DO NOT WARRANT THAT THE SOFTWARE WILL MEET YOUR REQUIREMENTS OR THAT OPERATION WILL BE UNINTERRUPTED OR EFFOR-FREE. TO THE FULLEST EXTENT PERMITTED BY LAW, WE HEREBY DISCLAIM (FOR OURSELF AND OUR AFFILIATES) ALL OTHER WARRANTIES, WHETHER EXPRESS OR IMPLIED, ORAL OR WRITTEN, WITH RESPECT TO OUR SERVICES, INCLUDING WITHOUT LIMITATION, ALL IMPLIED WARRANTIES OF TITLE, NON-INFRINGEMENT, QUIET ENJOYMENT, INTEGRATION, MERCHANTABILITY OR FITNESS FOR ANY PARTICULAR PURPOSE, AND ALL WARRANTIES ARISING FROM ANY COURSE OF DEALING, COURSE OF PERFORMANCE OR USEAGE OF TRADE. EXCEPT AS MAY BE SET FORTH IN A SEPARATE SERVICE LEVEL AGREEMENT, YOUR EXCLUSIVE REMEDY FOR ANY REPORTED DEFECT IN OUR SERVICES WILL BE FOR US TO PROVIDE ACCESS TO REPLACEMENT SOFTWARE WITHIN A REASONABLE TIME.**

**10. MUTUAL INDEMNIFICATION.**

**(a) Indemnification by Us.** We shall defend you against any claim, demand, suit, or proceeding ("Claim") made or brought against you by a third party alleging that your use of our Services infringes or misappropriates the intellectual property rights of a third party, and shall indemnify you for any damages finally awarded against, and for reasonable attorneys' fees incurred by, you in connection with any such Claim; provided, that you (i) promptly give us written notice of the Claim; (ii) give us sole control of the defense and settlement of the Claim (provided that we may not, without your prior approval, settle any Claim unless the settlement unconditionally releases you of all liability); and (iii) provide to us all reasonable assistance, at your expense.

**(b) Indemnification by You.** You shall defend us against any Claim made or brought against us by a third party alleging that Your Data, or your use of our Services, infringes or misappropriates the intellectual property rights of a third party, or violates applicable law, and shall indemnify us for any damages finally awarded against, and for reasonable attorneys' fees incurred by, us in connection with any such Claim; provided, that we (i) promptly give you written notice of the Claim; (ii) give you sole control of the defense and settlement of the Claim (provided that you may not, without our prior approval, settle any Claim unless the settlement unconditionally releases us of all liability); and (iii) provide to you all reasonable assistance, at your expense.

**(c) Exclusive Remedy.** This Section states the indemnifying party's sole liability to, and the indemnified party's exclusive remedy against, the other party for any type of Claim described in this Section.

**11. LIMITATION OF LIABILITY. TO THE FULLEST EXTENT PERMITTED BY LAW, NEITHER LICENSOR, NOR ANY MEMBER OF OUR TEAM, SHALL BE LIABLE TO YOU FOR ANY LOST PROFITS OR REVENUES, OR FOR ANY CONSEQUENTIAL, INCIDENTAL, INDIRECT, SPECIAL OR PUNITIVE DAMAGES ARISING OUT OF OR IN CONNECTION WITH OUR SERVICES, OR THIS AGREEMENT, EVEN IF THEY ARE BASED ON NEGLIGENCE OR WE HAVE BEEN ADVISED OF THE POSSIBILITY OF THOSE DAMAGES. IN NO EVENT SHALL OUR AGGREGATE LIABILITY FOR ANY DAMAGES BE MORE THAN THREE MONTHS OF FEES PAID BY YOU. SOME JURISDICTIONS DO NOT ALLOW LIMITATIONS ON INCIDENTAL OR CONSEQUENTIAL DAMAGES, SO THE ABOVE LIMITATIONS MAY NOT APPLY TO YOU. YOU AGREE THAT ANY CLAIM YOU MAY HAVE ARISING OUT OF OR RELATED TO THIS AGREEMENT, OR YOUR RELATIONSHIP WITH LICENSOR, MUST BE FILED WITHIN ONE (1) YEAR AFTER SUCH CLAIM AROSE; OTHERWISE, YOUR CLAIM IS PERMANENTLY BARRED.**

**12. NOTICES; GOVERNING LAW; JURISDICTION.**

**(a) General.** Who you are contracting with, to whom you should direct notice, what law will apply in any lawsuit arising out of the Agreement, and which court can adjudicate such lawsuit are as follows:

Who you are contracting with:	Clubessential, LLC
Legal notices should be sent to:	Subject Line: Legal Notice Jonathan Hill, Esq. General Counsel <a href="mailto:jhill@clubessential.com">jhill@clubessential.com</a>
The governing law is:	Ohio
The courts having exclusive jurisdiction are:	State courts of Hamilton County, Ohio, or the U.S. District Court for the Southern District of Ohio, as applicable.

**(b) Manner of Giving Notice.** Except as otherwise specified in this Agreement, all notices, permissions and approvals hereunder shall be in writing and shall be deemed to have been given upon (i) personal delivery; (ii) the second business day after mailing; (iii) the second business day after sending by confirmed facsimile; or (iv) the first business day after sending by email (provided email shall not be sufficient for notices of termination or an indemnifiable claim). Notices to you shall be addressed to the designated contact person identified in the Services Agreement at the email address or physical address listed.

**(c) Agreement to Governing Law and Jurisdiction.** Each party agrees to the applicable governing law above without regard to choice or conflicts of law rules, and to the exclusive jurisdiction of the applicable courts above.

**(d) Waiver of Jury Trial.** Each party hereby waives any right to jury trial in connection with any action or litigation in any way arising out of or related to this Agreement.

### 13. DISPUTE RESOLUTION.

**(a) Negotiation.** Each party will attempt, in good faith, to resolve any dispute arising out of or relating to the Agreement promptly by negotiation between executives who have the authority to settle the controversy and who are at a higher level of management than the persons with direct responsibility for administration of the Agreement. Any party may give the other party written notice of any dispute not resolved in the normal course of business. Within 15 days after delivery of the notice, the receiving party shall submit to the other a written response. The notice and response shall include with reasonable particularity (a) a statement of each party's position and summary of arguments supporting that position, and (b) the name and title of the executive who will represent that party and of any other person who will accompany the executive. Within 30 days after delivery of the notice, the executives of both parties shall meet at a mutually acceptable time and place. Unless otherwise agreed in writing by the negotiating parties, the above-described negotiation shall end at the close of the first meeting of executives described above (the "First Meeting"). Such closure shall not preclude continuing or later negotiations, as desired. All offers, promises, conduct and statements, whether written or oral, made in the course of the negotiation by any of the parties, their agents, employees, experts and attorneys are confidential, privileged and inadmissible for any purpose, including impeachment, in arbitration or other proceeding involving the parties, provided that evidence that is otherwise admissible or discoverable shall not be rendered inadmissible or non-discoverable as a result of its use in the negotiation. At no time prior to the First Meeting shall either side initiate an arbitration or litigation related to this Agreement except to pursue a provisional remedy that is authorized by law, or by agreement of the Parties. All applicable statutes of limitation and defenses based upon the passage of time shall be tolled while the dispute resolution procedures specified herein are pending and for 15 calendar days thereafter.

**(b) Non-Binding Mediation.** If the matter cannot be resolved by negotiation, then the Parties agree to submit the dispute to non-binding mediation prior to filing any civil action. Non-binding mediation shall be considered a condition precedent to the filing of any lawsuit under the Agreement.

### 14. GENERAL PROVISIONS.

**(a) Independent Contractor Relationship.** Our legal relationship to you is that of an independent contractor. This Agreement does not form a partnership, franchise, joint venture, employment, agency and/or fiduciary relationship between you and us.

**(b) Export Compliance.** Each party shall comply with the export laws and regulations of the United States and other applicable jurisdictions in providing and using the Services. Without limiting the foregoing, (i) each party represents that it is not named on any U.S. government list of persons or entities prohibited from receiving exports; (ii) you shall not permit users to access or use the Software or Application Server in violation of any U.S. export embargo, prohibition or restriction; and (iii) you will not export, re-export, divert, transfer or disclose any portion of the Licensor's products or services, or any related technical information or materials, directly or indirectly, in violation of any applicable export law or regulation.

**(c) Third Party Applications and Your Data.** If you enable or install any third-party application for use with our Services, you acknowledge that we may allow providers of those third-party applications to access Your Data as required for the interoperability of such third-party application and our Services. We shall not be responsible for any disclosure, modification or deletion of Your Data from any such access by third-party application providers.

**(d) No Third-Party Beneficiaries.** There are no third-party beneficiaries to this Agreement.

**(e) Waiver and Cumulative Remedies.** No failure or delay by either party in exercising any rights under this Agreement shall constitute a waiver of that right. Other than as expressly stated herein, the remedies provided herein are in addition to, and not exclusive, of any other remedies of a party at law or in equity.

**(f) Severability.** If any provision of this Agreement is held by a court of competent jurisdiction to be contrary to law, the provision shall be modified by the court and interpreted so as best to accomplish the objectives of the original provision to the fullest extent permitted by law, and the remaining provisions of this Agreement shall remain in effect.

**(g) Survival.** Section 6 (Ownership Rights), Section 8 (Confidentiality), Section 9 (Warranties and Disclaimers), Section 10 (Mutual Indemnification), Section 11 (Limitation of Liability); Section 12 (Notice; Governing Law; Jurisdiction); and Section 13 (Dispute Resolution) shall survive any termination of this Agreement.

**(h) Assignment.** Neither party may assign any of its rights or obligations hereunder, whether by operation of law or otherwise, without the prior written consent of the other party (not to be unreasonably withheld). Notwithstanding the foregoing, either party may assign this Agreement in its entirety without consent of the other party, to its affiliate or in connection with a merger, acquisition, corporate reorganization, or sale of all or substantially all of its assets not involving a direct competitor of the other party. Subject to the foregoing, this Agreement shall bind and inure to the benefit of the parties, their respective successors and permitted assigns.

**(i) Headings.** The captions and headings appearing in this Agreement are for reference only and will not be considered in construing this Agreement.

**(j) Entire Agreement.** This Agreement, including all exhibits and addenda hereto, and all Services Agreements, as amended from time to time, constitute the entire agreement between the parties and supersedes all prior and contemporaneous agreements, proposals or representations, written or oral, concerning its subject matter. No modifications, amendments, or waiver of any provision of this Agreement shall be effective unless in writing and either signed or accepted electronically by the party against whom the modification, amendment or waiver is to be asserted. However, to the extent of any conflict or inconsistency between the provisions of this Agreement and any exhibit or Services Agreement, the terms of such exhibit or Services Agreement shall prevail.

ACCEPTED BY LICENSEE: Initials: LOLO

EXHIBIT  
B

**ACCEPTABLE USE POLICY**

This Acceptable Use Policy sets forth our policies relating to the types of content that you may upload to your website when using our Services. We reserve the right to remove any materials that, in our sole discretion, may be illegal, may subject us to liability, or which may violate this Acceptable Use Policy. We will cooperate with legal authorities in the investigation of any suspected or alleged crime or civil wrong arising from any use of our Services.

**PLEASE NOTE!** Your violation of this Acceptable Use Policy may result in the suspension or termination of either your access to the Services and/or your account, or other actions as detailed in the PrestoSports Services Agreement (the "Services Agreement"), as applicable, or Terms of Service, in the absence of a signed Services Agreement.

**1. ACCEPTABLE USE POLICY.** The following constitute violations of this Acceptable Use Policy:

- Using the Services to transmit or post any material that contains or contains links to nudity, pornography, adult content, sexual content, or extreme violence.
- Using the Services to transmit or post any material that, intentionally or unintentionally, violates any applicable local, state, national or international law, or any rules or regulations promulgated there under.
- Using the Services to harm, or attempt to harm, minors in any way.
- Using the Services to transmit or post any material that harasses, threatens or encourages bodily harm or destruction of property.
- Using the Services to make fraudulent misrepresentations or offers including but not limited to offers relating to "pyramid schemes" and "Ponzi schemes."
- Using the Services to access, or to attempt to access, the accounts of others, or to penetrate, or attempt to penetrate, security measures of Licensor or another entity's computer software or hardware, electronic communications system or telecommunications system, whether or not the intrusion results in the corruption or loss of data.
- Using the Services to transmit or post any material that infringes any copyright, trademark, patent, trade secret or other proprietary rights of any third party, including, but not limited to, the unauthorized copying and/or distribution of copyrighted material, the digitization and distribution of photographs from magazines, books, music, video or other copyrighted sources, and the unauthorized transmittal of copyrighted software.
- Using the Services to collect, or attempt to collect, personal information about third parties without their knowledge or consent.
- Reselling the Services without the prior written authorization of Licensor.
- Using the Services to send (unsolicited commercial email) spam
- Using the Services for any activity that adversely affects the ability of other people or systems to use the Services or the Internet. This includes but is not limited to "denial of service" (DoS) attacks against another network host or individual user. Interference with or disruption of other network users, network services or network equipment is prohibited.

**2. REPORTING PROCEDURE.** If you believe there has been a violation of this Acceptable Use Policy, please report it to us immediately.

By Email	By Phone
<a href="mailto:support@prestosports.com">support@prestosports.com</a>	(301) 656-5504

\*\* We reserve the right to revise, amend or modify this Acceptable Use Policy at any time and in any manner by providing you with a written notice of such changes.

## SERVICES LEVEL AGREEMENT

This Service Level Agreement for PrestoSports ("PrestoSports SLA") sets forth the details regarding the level of service and technical support that apply when your account is in good financial standing. This PrestoSports SLA expressly incorporates all terms, conditions and definitions described in the PrestoSports Services Agreement (the "Services Agreement"), as applicable, and/or the Terms of Services (in the absence of a signed Services Agreement).

### 1. DOWNTIME

For purposes of this PrestoSports SLA, a Unit of Downtime is one period of at least one (1) hour during which access to your website using our Services is unavailable because of problems with hardware or system software. Downtime does not include (i) problems caused by factors outside of our reasonable control, (ii) problems resulting from any actions or inactions by you or any third party, (iii) problems resulting from your equipment and/or third-party equipment not within our sole control, or (iv) network unavailability during scheduled maintenance of our network and/or web servers.

In any calendar month, our guarantees that Downtime will not exceed four (4) Units of Downtime excluding, however, regularly scheduled maintenance. Any regularly scheduled maintenance will be performed during the hours of 2 am EST and 8 am EST.

If Downtime exceeds four (4) Units of Downtime in any calendar month, we will, upon your written request, credit your account (a "Downtime Credit") in an amount equal to the pro-rata price for one (1) day of service, for each instance of Downtime as that term is defined herein.

To receive Downtime Credit, you must request such credit by sending an email to [support@prestosports.com](mailto:support@prestosports.com) within seven (7) days after the occurrence of Downtime. The aggregate maximum number of Downtime Credits to be issued for any and all instances of Downtime occurring in a single calendar month will not exceed seven (7) Downtime Credits. Downtime Credits will be applied upon issue of the first invoice following the request for Downtime Credit, unless the Downtime occurs in our final month of service. In such case, a refund for the dollar value of the Downtime Credit will be mailed to you within thirty (30) days of the expiration of our agreement with you.

### 2. TECHNICAL SUPPORT

A member of our technical support staff shall provide "Technical Support" over toll-free telephone lines and email support from 9:00 am EST to 8:00 pm PST Monday through Saturday (our "Core Support Hours"), and outside of Core Support Hours on an emergency basis by calling our support hot line which is staffed by a team that has the appropriate escalation procedures to respond (our "Hot Line Support"). Hot Line Support is for emergencies such as (i) any malfunction of the Services that materially prevents you from performing normal business functions; (ii) any outage of the Services; and/or (iii) c) a need for support information, the lack of which would materially prevent you from performing normal business functions before regular business hours resume.

Our customer support includes answering questions regarding the use of our Services; assistance changing the configuration of the Software and/or Application Server; occasional one-on-one training in proper use of our Services; and providing standard education classes. Our customer support does not include conducting custom education classes; conducting custom education onsite; providing remote or onsite consultation; creating new designs or artwork; or performing front-end development or programming.

### 3. SUPPORT CONTACT INFORMATION

You may contact our technical support help desk:

By Email	By Phone
<a href="mailto:support@prestosports.com">support@prestosports.com</a>	(301) 656-5504

We may, from time to time, add new channels for you to contact the help desk and will make such information known to you through our website: [www.prestosports.com](http://www.prestosports.com).

## WEBSITE ACCESSIBILITY NOTICE

We are committed to assisting you promote and offer accessible products. This includes designing websites to be as inclusive as possible so that you have the opportunity to offer generated content that is accessible to all of your users.

At your option, we will implement website accessibility criteria set forth in the Accessibility Conformance Report<sup>1</sup> that "Support" Web Content Accessibility Guidelines 2.0 ("WCAG 2.0") at the cost set forth in the Pricing Agreement. A criterion "Supports" WCAG 2.0 when the functionality of the product has at least one method that meets the criterion without known defects or meets with equivalent facilitation. A criterion "Supports with Exceptions" when some functionality of the product does not meet the criterion.

You acknowledge that implementation and accessibility of the foregoing criteria may require additional action by you. Conformance of all criteria is subject to the limitations and exceptions set forth in the Accessibility Conformance Report. It is your responsibility to upload accessible content. We cannot control, nor are we responsible, for any content that is uploaded or modified on the website by you.

Upon your election, we will use commercially reasonable efforts to implement the website accessibility criteria that "Support" WCAG 2.0 as provided in the Accessibility Conformance Report. In the event that you assert that we did not meet any accessibility standard, including WCAG 2.0, we will work with you to attempt to address concerns, however additional fees may apply. While implementing the accessibility features will improve the accessibility of the website, we do not guarantee or warrant the accessibility of our Software, that all WCAG 2.0 accessibility requirements have been met, or that our Services otherwise comply with WCAG 2.0, Section 508 of the Rehabilitation Act, the Americans with Disabilities Act, or any applicable federal or state laws or regulations relating to accessibility for persons with disabilities. **We shall not be liable for loss or damage to you or any user of your website as a result of inaccessibility of our products or services, or our failure to comply with the foregoing standards or applicable law relating to accessibility for persons with disabilities.**

---

<sup>1</sup> The Accessibility Conformance Report is incorporated herein by reference. Licensor will maintain the Accessibility Conformance Report at <http://support.prestosports.com/customer/portal/articles/2905089-prestosports-accessibility-conformance-report> with a current list of supported and non-supported criteria.

**Date:** October 3, 2018  
**Submitted by:** Dr. Debra Daniels, Superintendent/President  
**Area Administrator:** Dr. Debra Daniels, Superintendent/President  
**Subject:** Request for Approval

---

**Board Meeting Date:** October 10, 2018

**Title of Board Item:**

Professional Services Agreement with Trudi Radtke in Association with the Zero Textbook Cost Degree Grant

**Background:**

Taft College is a participant in the Zero Textbook Cost Degree grant program. As part of the part of the program, the College recommends entering into an agreement with Trudi Radtke to develop Open Educational Resources (OER) curriculum development for the ADMJ 1508 Introduction to Corrections course textbook and materials.

**Terms (if applicable):**

October 15, 2018 - January 15, 2019

**Expense (if applicable):**

80 Hours at \$18.75 per Hour (Total Not to Exceed \$1,500.00)

**Fiscal Impact Including Source of Funds (if applicable):**

Expense is Included in the Zero Textbook Cost Grant

**Approved:**   
\_\_\_\_\_  
Dr. Debra Daniels, Superintendent/President

# WEST KERN COMMUNITY COLLEGE DISTRICT CONTRACT FOR PROFESSIONAL SERVICES

## PROFESSIONAL SERVICES AGREEMENT DEVELOPMENT OF OPEN EDUCATIONAL RESOURCES ("OER") "INTRODUCTION TO CORRECTIONS"

---

October 15, 2018 – January 15, 2019

This Professional Services Agreement ("Agreement") is between West Kern Community College District ("District"), a California community college district and political subdivision of the State of California, and **Trudi Radtke** ("Contractor"), an individual residing in the State of California. District and Contractor are also referred to collectively as the "Parties" and individually as "Party."

WHEREAS, District is authorized by Section 53060 (see Appendix 14) of the California Government Code to contract with and employ any persons for the furnishing of special services and advice in financial, economic, accounting, engineering, legal or administrative matters, if such persons are specially trained and experienced and competent to perform the special services required; and

WHEREAS, District is in need of such special services and advice; and

WHEREAS, Contractor is specially trained and experienced and competent to perform the special services required by the District, and such services are needed on a limited basis;

NOW, THEREFORE, in consideration of these mutual promises, the Parties agree as follows:

1. Scope of Service. Contractor's services will be performed, findings obtained, reports and recommendations prepared in accordance with generally and currently accepted principles and practices of his/her profession. Services to be provided by Contractor ("Work"):

- **Contractor will provide OER curriculum development services for District in association with the "Zero Textbook Cost Degree" grant provided by the California Community Colleges Chancellor's Office.**
- **Contractor will prepare course materials for an Introduction to Corrections textbook (ADMJ 1508)**
- **Contractor shall complete a draft of the course and submit them to District's Grant Director, and Chair of the Administration of Justice Program ("District Approvers"), in Word format via electronic mail by December 15, 2018 for review. Contractor shall work with District Approvers for any edits that are needed.**
- **Contractor shall submit the finalized course material to District Approvers in Word format via electronic mail no later than January 15, 2019.**

Contractor agrees and understands that District does not and will not take any responsibility for the storage, archiving or distribution of Contractor's instructional materials, textbooks, etc., and/or other supplies related to this program.

2. Term. This Agreement shall commence on **October 15, 2018 and shall continue in full force and effect thereafter until and including January 15, 2019.** ("Term") unless this Agreement is terminated during the Term pursuant to this Agreement.

3. Payment.

A. Amount of Compensation. District agrees to pay Contractor, as full consideration and compensation for Contractor's performance of the Work under this Agreement, **80 hours at \$18.75** for a total amount not to exceed **One Thousand, Five Hundred Dollars (\$1500)** ("Contract Amount")



B. For Reimbursement of Expenses. Unless otherwise agreed upon by District in writing or specifically provided in this Agreement, Contractor shall assume and pay, at Contractor's sole expense, all costs and expenses incurred by Contractor in performing the Work under this Agreement ("Expenses").

C. Method and Schedule of Payment. District shall pay to Contractor the Contract Amount pursuant to invoice from Contractor in accordance with this Agreement.

**Invoice.** Contractor shall submit to District detailed billing information regarding the Work provided for the billing period, not more than once per month, and, **if applicable, District-authorized Expenses** incurred during the billing period. All **District-authorized Expenses** shall be documented with **original itemized receipts** and shall be **pre-approved in writing by District** unless such expenses are specifically authorized by this Agreement. Invoices must be sent to the attention of Fiscal Services and shall include the invoice date, date(s) of service(s), District's Purchase Order number, and Contractor's Taxpayer Identification Number. Invoices shall be paid on a "net 30-day basis" for Work satisfactorily rendered (as determined by the District) pursuant to this Agreement. An invoice cannot be paid unless this Agreement has been signed by Contractor and has been properly executed by District, and Contractor has submitted a completed Vendor Form/Substitute Form W-9 to District's Contract and Procurement Services Department. **FINAL INVOICE MUST BE RECEIVED BY DISTRICT NO LATER THAN FEBRUARY 15, 2019 IN ORDER TO RECEIVE PAYMENT.**

4. California State Tax Withholding for Nonresidents of California. It is mutually understood that if Contractor is a Nonresident of California, which may include California Nonresidents, corporations, limited liability companies, non-profits, and partnerships that do not have a permanent place of business in the State of California, the District is obligated to abide by California Franchise Tax Board (FTB) withholding requirements. The District is required to withhold from all payments or distributions of California source income made to a Nonresident when payments or distributions are greater than One Thousand Five Hundred Dollars (\$1,500) for the calendar year unless the District receives authorization for a waiver or a reduced withholding rate from the Franchise Tax Board. As of January 1, 2008, the standard withholding amount for all payments to Nonresident California Contractors is Seven Percent (7%). District will deduct the amount ordered by the State of California from the payment hereunder and will pay such amount directly to the Contractor's California State Income Tax Account, settlement of which must be made by Contractor directly with the State of California through Withholding Coordinator, Franchise Tax Board, PO Box 651, Sacramento, California, 95812-0651; telephone (916) 845-6262. Completion and submission of the appropriate form shall be the obligation of the Nonresident Contractor and Contractor shall defend, indemnify and hold harmless the District against any loss, expense, or liability arising out of Contractor's acts or omissions with respect to this nonresident requirement. Contractor shall provide all necessary documentation and information to help District comply with all tax requirements related to California nonresidents.

5. Trademark/Logo Use. Contractor must obtain written approval from District's Public Information Office ("PIO") to use the District's name and/or logos in any advertisements, promotions, press releases or other media. In the event such permission is extended, PIO will furnish Contractor with camera-ready artwork for such use. District, at its sole discretion, may limit or otherwise place conditions on Contractor's use of District's name, and/or logos in which case such limitations shall be incorporated into this Agreement. Contractor shall not revise, change, or otherwise alter any material related to District's name and/or logo without written consent from District.

6. Independent Contractor. Contractor, in the performance of this Agreement, shall be and act as an independent contractor and not an employee of District. Contractor, understands and agrees that he/she and all of his/her employees shall not be considered officers, employees or agents of the District, and are not entitled to benefits of any kind or nature normally provided employees of the District and/or to which District's employees are normally entitled, including, but not limited to, State Unemployment Compensation or Worker's Compensation. Contractor assumes the full responsibility his/her acts and/or liabilities including those of his/her employees or agents as they relate to the Work to be provided under this Agreement. Contractor shall assume full responsibility for withholding and payment of all: federal, state, local and applicable income taxes; workers' compensation; contributions, including but not limited to, unemployment insurance and social security with respect to Contractor and Contractor's employees. Contractor should be aware the IRS regulations require District to report total income exceeding six hundred dollars (\$600) under this and any additional Agreements in any given year. The District will not withhold taxes, unemployment insurance or social security for Contractor or Contractor's employees or independent subcontractors. Contractor agrees to indemnify and hold District harmless from and against any and all liability arising from any failure or alleged failure of Contractor to withhold or pay any applicable tax, unemployment insurance or social security when due or any failure or alleged failure to comply with any applicable regulation applicable to Contractor's employees.

7. Use of Subcontractors. Contractor must obtain District's prior written approval to use any subcontractors while performing any portion of this Agreement and such approval may be conditioned on approval of the subcontract between Contractor and subcontractor. Such approval must include approval of the proposed subcontractor and the terms of compensation. District retains the right to obtain copies of subcontractor insurance coverage at any time. Nothing in this Section shall be interpreted as creating a contractual relationship between District and any approved subcontractor. Notwithstanding District's approval of any subcontractor's contract, Contractor shall remain solely responsible for any harm, damage, or claim arising from any subcontractor's acts or omissions as set forth in Section 14.

8. Public Retirement System Retirees. Contractor must disclose to District if Contractor has retired from the California State Teachers' Retirement System ("CalSTRS") or the California Public Employees' Retirement System ("CalPERS"). Pursuant to California Education Code Section 24214 and 24214.5, there are postretirement limitations on earnings if Contractor has retired from CalSTRS and hours worked limitations if Contractor has retired from CalPERS. If Contractor has retired from either CalSTRS or CalPERS, Contractor should be aware that the District is required to report all payments under this and any additional Agreements in any given year (July 1 – June 30).  
CalSTRS or CalPERS: \_\_\_\_\_ Agency Retired From: \_\_\_\_\_ Retirement Date: \_\_\_\_\_

9. Materials and Expenses. Contractor shall furnish, at his/her own expense, all labor, materials, equipment, supplies and other items necessary to complete the Work to be provided pursuant to this Agreement. District shall not be liable to Contractor for any costs or expenses paid or incurred by Contractor in performing Work for District.

10. Policies & Procedures and Rules & Regulations. Contractor will comply with District's policies, procedures, rules and regulations and applicable laws.

11. Originality of Services.

1. Matters Produced Under this Agreement. Contractor understands and agrees that all matters produced under this Agreement shall become the property of District and cannot be used without District's express written permission. District shall have all right, title and interest in said matters, including the right to secure and maintain the copyright, trademark and/or patent of said matter in the name of the District. Contractor consents to use of Contractor's name in conjunction with the sale, use, performance and distribution of the matters, for any purpose and in any medium.
2. Contractor Use of Other Copyright/Trademark/Patent Materials. Contractor is responsible for arranging and paying for all rights and copyrights necessary and for all costs arising from the use of any material covered by copyright, patent, trademark or franchise. Contractor agrees to indemnify, defend and hold harmless the District from any claims or costs, including legal fees, which might arise from questionable use of any such material. The District reserves the right to require verification.
3. Creative Commons Attribution License. Contractor agrees that any works created under this Agreement funded by the California Community Colleges Chancellor's Office carries the Creative Commons Attribution License that gives permission to the public to reproduce, distribute, perform, display, or adapt the licensed materials for any purpose so long as the user gives attribution to the author.

12. Funding. This Agreement is subject to the procurement of adequate funding, which may be subject to reductions, limitations or conditions that may affect the provisions, terms, or funding of this Agreement in any manner. The District reserves the right to adjust the Scope of Work, Contract Amount, and/or cancel this Agreement if funds become unavailable for which Work is provided. The termination notice period shall be reduced to thirty (30) days if the grant is not renewed and funding is no longer available.

13. Termination. This Agreement shall terminate upon expiration of the Term. Any termination of this Agreement during the Term shall be in accordance with the following:

1. Termination for Convenience. During the Term of this Agreement, District may terminate this Agreement at any time at its convenience and without cause, upon providing Contractor at least ten (10) days written notice before the effective date of termination. Upon such termination by District, Contractor shall only be entitled to payment for all Work provided, rendered, and received by District prior to the date of termination and in no event shall Contractor be entitled to any payment or reimbursement as the result of District's termination.

2. Other Grounds. Notwithstanding any provisions in this Agreement, District, at District's sole discretion and upon written notice to Contractor, shall have the right to terminate this Agreement effective on the date stated in District's written notice in the event District determines, at its sole discretion, that Contractor (i) is unable or unwilling to perform the Work or meet any obligation or duty as described or made necessary by the Agreement, (ii) changes the nature of its business so that it is not compatible with the mission or needs of the District or is involved in any incident or activity which embarrasses, creates unwelcome scrutiny or attention, or otherwise causes or threatens harm to the reputation of the District, or (iii) fails to comply with federal, state, and/or local laws applicable to Contractor's performance of the Work under this Agreement.

14. Indemnification. Contractor agrees to defend, hold harmless and indemnify District, its parent, affiliates, subsidiaries, authorized representatives, directors, officers, agents and employees against any and all liability for any judgments, awards, expenses, fines, penalties, attorneys' fees, costs, or other claims for damages in connection with any suit, complaint, charge, proceeding or action of any kind alleging a violation of any statutory or regulatory provision or otherwise arising out of the negligent act or willful misconduct by Contractor, of its duties and responsibilities under this Agreement, unless such performance or nonperformance occurred at the direction of or was caused by District. This hold harmless and indemnification includes but is not limited to compensatory damages, punitive damages, regulatory fines and penalties, and extra-contractual liability and shall survive the termination of this Agreement.

15. Insurance. Contractor agrees to maintain, in full force and effect, at Contractor's expense, the following insurance coverages from an admitted carrier in the State of California with a Best Rating of A-VII or higher: (i) Commercial General Liability insurance, with limits of not less than One Million Dollars (\$1,000,000) per occurrence including bodily injury, broad form property damage and blanket contractual liability, written on an "occurrence" form; (ii) Professional Liability Insurance with limits of not less than One Million Dollars (\$1,000,000); (iii) Employer's Liability with limits of not less than One Million Dollars (\$1,000,000) per occurrence; (iv) Workers' Compensation insurance as required by statutory insurance requirement of the State of California; and (v) Automobile Liability covering all owned, non-owned and hired vehicles with combined single limit for bodily injury and/or property damage of not less than One Million Dollars (\$1,000,000).

Contractor agrees to name District, Taft College, District's Board of Trustees, its officers, agents, and employees as Additional Insured under its policy(ies). Contractor shall deliver Certificate(s) of Insurance and Additional Insured Endorsement(s) evidencing the required coverages to the District, which shall be subject to the District's approval for adequacy of protection. The Certificate(s) of Insurance shall provide thirty (30) days prior written notice of cancellation. All certificates must be faxed or emailed, followed by a hard-copy in the mail to District,

16. Transportation. Contractor hereby acknowledges and understands that it is his/her responsibility to arrange for transportation to provide all Work necessary and/or required by this Agreement and is solely responsible for all associated costs. The District is in no way responsible for, nor does District assume any liability for, any injury or loss which may result from Contractor's transportation for which the Contractor shall indemnify the District in accordance with Section 14 above.

17. Assignment. The obligations of the Contractor pursuant to this Agreement shall not be assigned by the Contractor without the express, written approval of the District.

18. Compliance with Applicable Laws. The Work completed herein must meet the approval of the District and shall be subject to the District's general right of inspection to secure the satisfactory completion thereof. Contractor agrees to comply with all federal, state and local laws, rules, regulations and ordinances that are now or may in the future become applicable to Contractor, Contractor's business, equipment and personnel engaged in operations covered by this Agreement or accruing out of the performance of such operations ("Rules"). If District disapproves of any service provided by Contractor, or if Contractor fails to comply with any applicable Rule, Contractor shall address the issue immediately at no additional cost to District.

19. Permits/Licenses. Contractor and all Contractor's employees or agents shall secure and maintain in force such permits and licenses as are required by law in connection with the furnishing of Work pursuant to this Agreement.

20. Professional Practices. All Work provided pursuant to this Agreement shall be provide in a manner consistent with the standards of care, diligence and skill ordinarily exercised by professionals in similar fields and circumstances in accordance with sound professional practices.

21. Confidentiality. Subject to any state or federal laws requiring disclosure (e.g., the California Public Records Act), the Parties agree, during the term of this Agreement and for five (5) years after termination or expiration of Agreement, to hold each other's proprietary or confidential information in strict confidence, except for any information protected under confidentiality laws which shall be held in such confidence in perpetuity. Parties agree not to provide each other's proprietary or confidential information in any form to any third party or to use each other's proprietary or confidential information for any purpose other than the implementation of, and as specified in, this Agreement. Each Party agrees to take all reasonable steps to ensure that proprietary or confidential information of either Party is not disclosed or distributed by its employees, agents or consultants in violation of the provisions of this Agreement.

22. Employment with Public Agency. Contractor, if an employee of another public agency, agrees that Contractor will not receive salary or remuneration, other than vacation pay, as an employee of another public agency for the actual time in which Work is actually being performed pursuant to this Agreement.

23. Entire Agreement/Amendment. The Agreement documents consist of this Agreement, any exhibits attached to or referenced herein, and all amendments and/or modifications issued in writing, duly approved by District's Board of Trustees, and executed by the Parties after the release of this Agreement. Conflicting provisions hereof, if any, shall prevail in the following descending order of precedence: (a) provisions set forth in this Agreement, (b) provisions set forth in any referenced attachments or exhibits to this Agreement attached or incorporated herein by reference.

24. Non-Discrimination. Contractor agrees not to engage in unlawful discrimination in the employment of persons, or in the acceptance, assignment, treatment, evaluation or compensation of students who participate in programs sponsored or arranged by District, on the basis of race, color, religion, nationality, national origin, ancestry, sex, gender, gender identity, gender expression, ethnicity, age, medical condition, mental or physical disability, marital status, sexual orientation or Vietnam-era veteran status.

25. Non-Waiver. The failure of District or Contractor to seek redress for violation of, or to insist upon, the strict performance of any term or condition of this Agreement, shall not be deemed a waiver by that Party of such term or condition, or prevent a subsequent similar act from again constituting a violation of such term or condition.

26. Notice. All notices or demands to be given under this Agreement by either Party to the other Party shall be in writing and given either by: (a) personal service or (b) by U.S. Mail, mailed either by certified or registered mail, return receipt requested, with postage prepaid. Service shall be considered given when received, if personally served, or, if mailed, on the third day after deposit in any U.S. Post Office. The address to which notices or demands may be given by either Party may be changed by written notice given in accordance with the notice provisions of this Section. At the date of this Agreement:

District:

West Kern Community College District  
Attn: Mike Jiles/Tabitha Raber  
29 Cougar Ct., Taft CA CA 93268  
Phone: (661) 301-0826  
Email: [traber@taftcollege.edu](mailto:traber@taftcollege.edu)

Contractor:

**Trudi Radtke**

**Email: [trudi.radtke@canyons.edu](mailto:trudi.radtke@canyons.edu)**

A Party may change its/his/her designated representative and/or address for the purpose of receiving notices and communications under this Agreement by notifying the other Party of the change in writing and in the manner described in this Section.

27. Severability. If any term, condition or provision of this Agreement is held by a court of competent jurisdiction to be invalid, void or unenforceable, the remaining provisions will nevertheless continue in full force and effect, and shall not be affected, impaired or invalidated in any way.

28. Exhibits. All exhibits referenced herein and attached hereto shall be deemed incorporated into and made a part of this Agreement by each reference as though fully set forth in each instance in the text hereof.

29. Interpretation. In interpreting this Agreement, it shall be deemed to have been prepared by the Parties jointly, and no ambiguity shall be resolved against District on the premise that it or its attorneys were responsible for drafting this Agreement or any provision hereof. The captions or heading set forth in this Agreement are for convenience only and in no way define, limit, or describe the scope or intent of any Sections or other provisions of this Agreement. Any reference in this Agreement to a Section, unless specified otherwise, shall be a reference to a Section of this Agreement.

30. Conflict of Interest. Contractor hereby represents, warrants and covenants that (i) at the time of execution of this Agreement, Contractor has no interest and shall not acquire any interest in the future, whether direct or indirect, which would conflict in any manner or degree with the performance of Work under this Agreement; (ii) Contractor has no business or financial interests which are in conflict with Contractor's obligations to District under this Agreement; and (iii) Contractor shall not employ in the performance of Work under this Agreement any person or entity having any such interests.

31. Governing Law. The terms and conditions of this Agreement shall be governed by the laws of the State of California with venue in Los Angeles, California.

32. Authority to Execute. The individual(s) executing this Agreement on behalf of the Contractor is/are duly and fully authorized to execute this Agreement on behalf of Contractor and to bind the Contractor to each and every term, condition and covenant of this Agreement.

33. Approval by District's Board of Trustees. Pursuant to Education Code Section 81655, this Agreement is not valid and does not constitute an enforceable obligation against District unless and until District's Board of Trustees has approved or ratified this Agreement as evidenced by a motion duly passed and adopted by the Board of Trustees.

34. Time is of the Essence. Time is of the essence with respect to all provisions of this Agreement.

35. Accessibility of Information Technology. Contractor hereby warrants that the Work to be provided under this Agreement complies with the accessibility requirements of Section 508 of the Rehabilitation Act of 1973, as amended (29 U.S.C §794d), and its implementing regulations set forth at Title 36, Code of Federal Regulations, Part 1194. Contractor agrees to promptly respond to and resolve any complaint regarding accessibility of its products brought to its attention. Contractor further agrees to indemnify and hold harmless the Santa Clarita Community College District, the Chancellor's Office of the California Community Colleges and any California community college using the Contractor's products from any claim arising out of its failure to comply with the aforesaid requirements. Failure to comply with these requirements shall constitute a breach and be grounds for termination of this Agreement.

36. Certification Regarding Debarment, Suspension or Other Ineligibility. (applicable to all agreements funded in part or whole with federal funds).

1. By executing this contractual instrument, Contractor agrees to comply with applicable federal suspension and debarment regulations, including, but not limited to, regulations implementing Executive Order 12549 (29 C.F.R. Part 98) (see Appendix 15).
2. By executing this contractual instrument, Contractor certifies to the best of its knowledge and belief that it and its principals:
  1. 1) Are not presently debarred, suspended, proposed for debarment, declared ineligible, or voluntarily excluded from covered transactions by any federal department or agency;
  2. 2) Have not, within a three-year period preceding the execution of this contractual instrument, been convicted of, or had a civil judgment rendered against them, for: (a) Commission of fraud or a criminal offense in connection with obtaining, attempting to obtain, or performing a public (Federal, State or Local) or private transaction or contract; (b) Violation of Federal or State antitrust statutes; (c) Commission of embezzlement, theft, forgery, bribery, falsification or destruction of records, making false statements, tax evasion, receiving stolen property, making false claims, or obstruction of justice; or (d) Commission of any other offense indicating a lack of business integrity or business honesty that seriously and directly affects Contractor's present responsibility;

3. 3) Are not presently indicted for, or otherwise criminally or civilly charged by any government entity (Federal, State or Local), with commission of any of the offenses enumerated in b.2) above, of this certification;
4. 4) Have not, within a three-year period preceding the execution of this contractual instrument, had one or more public transaction (Federal, State or Local) terminated for cause or default;
5. 5) Shall not, except as otherwise provided under applicable federal regulations, knowingly enter into any lower tier covered transaction with a person who is proposed for debarment, debarred, suspended, declared ineligible, or voluntarily excluded by any federal department or agency from participation in such transaction; and
6. 6) Include in all lower tier covered transactions, and all solicitations for covered transactions, provisions substantially similar to those set forth herein.

**SIGNATURES**

Executed at Taft, California, on the dates below:

Date of WKCCD Board Approval: \_\_\_\_\_ Budget Code: ZTC Grant 17-085-019

**West Kern Community College District**

**Independent Contractor**

Printed Name: **Dr. Debra Daniels**

Printed Name: **Trudi Radtke**

\_\_\_\_\_  
(Signature)

\_\_\_\_\_  
(Signature)

\_\_\_\_\_  
*Superintendent/President*  
(Title)

\_\_\_\_\_  
(Address)

\_\_\_\_\_  
(Social Security Number)

**Date:** September 26, 2018

**Submitted by:** Severo M. Balason, Jr., Vice President of Student Services

**Area Administrator:** Dr. Debra Daniels, Superintendent/President

**Subject:** Request for Approval

---

**Board Meeting Date:** October 10, 2018

**Title of Board Item:**

Renewal of Eureka Agency/User Site License Contract for January 1, 2019 through December 31, 2019

**Background:**

Eureka is an online assessment tool that allows the Career Center and Student Success instructors to deliver career development services more efficiently. This tool provides assessments in the areas of personality, skills, interests, values, learning styles, and more, and then connects the assessment results to career options that may lead to high levels of fulfillment, as well as educational options that the students may consider. Eureka is easily integrated into both counseling and classroom curriculum, allowing students and counselors/instructors to access results via web.

**Terms (if applicable):**

The term of the agreement is for January 1, 2019 through December 31, 2019.

**Expense (if applicable):**

The cost for services is \$1,496.14 which has been budgeted in the 2018-2019 budget.

**Fiscal Impact Including Source of Funds (if applicable):**

The cost for services is \$1,496.14 which has been budgeted in the 2018-2019 budget.

**Approved:**   
\_\_\_\_\_  
Dr. Debra Daniels, Superintendent/President



## **EUREKA, The California Career Information System**

---

September 14, 2018

**MAILING ADDRESS**

P.O. Box 687  
Pinole, CA 94564

**PHONE/FAX:**

Phone: (510) 669-0996  
Toll free: (888) 463-2247  
Fax: (510) 669-0992

**WEBSITE:**

[www.eurekanet.org](http://www.eurekanet.org)  
[www.eureka.org](http://www.eureka.org)

Taft College  
29 Emmons Park Dr  
Taft, CA 93268

Attention: Melissa Blanco

Dear Ms. Blanco:

Enclosed are two sets of your EUREKA License Amendment to extend your license from January 1, 2019 through December 31, 2019.

Please sign all copies, return one copy to us and retain one copy for your files.

Also enclosed is a Site Coordinator update form, please complete and email to: [Leonor@eurekanet.org](mailto:Leonor@eurekanet.org) or fax to (510) 669-0992 .

Please help us improve our services. If you have any questions about this contract, or the program, please do not hesitate to call our toll free number, 1 (888) 463-2247, my extension is 102, or you can email me at: [Leonor@eurekanet.org](mailto:Leonor@eurekanet.org)

Thank you for using EUREKA, the California Career Information System, we appreciate your being a part of the consortium.

Respectfully,



Leonor V. Gomez  
Contract Administrator



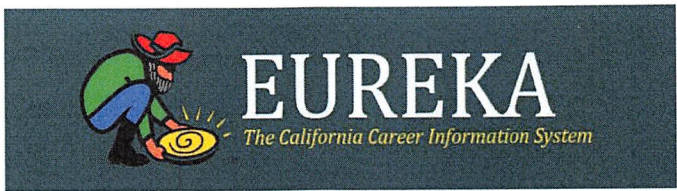

P.O. Box 687 Pinole, CA 94564-0687 1.888.463.2247

## Agency/User Site License Contract Amendment Contract Renewal Provision

### I. Purpose:

This addendum is to extend the subscription for the presently in-place Agency/User Site License Agreement. This amendment will continue and extend the **EUREKA WINDOWS AND INTERNET** License for:

**TAFT COLLEGE**

For the period from JANUARY 1, 2019 through DECEMBER 31, 2019

This agreement will hold constant the agreement between your agency and EUREKA. This signed and dated document will be attached and become part of the present contractual agreement and shall extend the agency/Site License Agreement with the undersigned and EUREKA for the dates indicated above.

### II. Fee Description:

License Fee	<b>\$1,595.00</b>
Group Discount	(\$ 200.00)
Sales tax	\$ 101.14
<b>Total:</b>	<b>\$1,496.14</b>

### III. Notice:

#### For the Agency:

\_\_\_\_\_  
Signature

\_\_\_\_\_  
Title

\_\_\_\_\_  
Date

#### For EUREKA:

L.V. Gomez   
\_\_\_\_\_  
Signature

**Contract Administrator**  
\_\_\_\_\_  
Title

9-14-18  
\_\_\_\_\_  
Date

### Billing Information:

Agency Coordinator: _____	Site Coordinator: _____
Address: _____	Address: _____
City _____ ST _____ Zip _____	City _____ ST _____ Zip _____
Phone: (     ) _____ Ext. _____	Phone: (     ) _____ Ext. _____
Purchase Order Number: _____	(Copy attached) last page original contract.

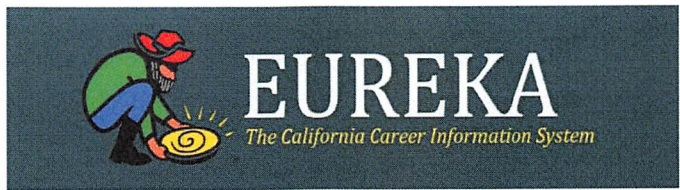

P.O. Box 687 Pinole, CA 94564-0687 1.888.463.2247

## Agency/User Site License Contract Amendment Contract Renewal Provision

### I. Purpose:

This addendum is to extend the subscription for the presently in-place Agency/User Site License Agreement. This amendment will continue and extend the **EUREKA WINDOWS AND INTERNET** License for:

### TAFT COLLEGE

For the period from JANUARY 1, 2019 through DECEMBER 31, 2019

This agreement will hold constant the agreement between your agency and EUREKA. This signed and dated document will be attached and become part of the present contractual agreement and shall extend the agency/Site License Agreement with the undersigned and EUREKA for the dates indicated above.

### II. Fee Description:

License Fee	\$1,595.00
Group Discount	(\$ 200.00)
Sales tax	\$ 101.14
<b>Total:</b>	<b>\$1,496.14</b>

### III. Notice:

#### For the Agency:

\_\_\_\_\_  
Signature

\_\_\_\_\_  
Title

\_\_\_\_\_  
Date

#### For EUREKA:

\_\_\_\_\_  
Signature *L.V. Gomez*

\_\_\_\_\_  
Title **Contract Administrator**

\_\_\_\_\_  
Date *9-14-18*

### Billing Information:

Agency Coordinator: \_\_\_\_\_ Site Coordinator: \_\_\_\_\_

Address: \_\_\_\_\_ Address: \_\_\_\_\_

City \_\_\_\_\_ ST \_\_\_\_\_ Zip \_\_\_\_\_ City \_\_\_\_\_ ST \_\_\_\_\_ Zip \_\_\_\_\_

Phone: ( ) \_\_\_\_\_ Ext. \_\_\_\_\_ Phone: ( ) \_\_\_\_\_ Ext. \_\_\_\_\_

Purchase Order Number: \_\_\_\_\_ (Copy attached) last page original contract.



**SITE COORDINATOR UPDATE FORM 2018-2019**  
Please fax to 510.669.0992 or email to [leonor@eurekanet.org](mailto:leonor@eurekanet.org)  
P.O.Box 687 Pinole, CA. 94564-0687

Site Name: \_\_\_\_\_

Site Phone Number: \_\_\_\_\_

Person filling out this Form: \_\_\_\_\_

Title: \_\_\_\_\_

Email Address: \_\_\_\_\_

**Name & Title of the EUREKA/ECOCIS Site-Coordinator (if different from above) for the coming year 2018-2019 (receives software & materials):**

Name: \_\_\_\_\_

Title: \_\_\_\_\_

Email Address: \_\_\_\_\_

**Name & Title of Technical Contact for 2018-2019 (Person in charge of software installation):**

Name: \_\_\_\_\_

Email Address: \_\_\_\_\_

Title: \_\_\_\_\_

**Name & Title of Staff Contacts for 2018-19 (Those using EUREKA/ECOCIS):**

Name: \_\_\_\_\_

Name: \_\_\_\_\_

Email Address: \_\_\_\_\_

Email Address: \_\_\_\_\_

Title: \_\_\_\_\_

Title: \_\_\_\_\_

You can fax this form or visit our website, [www.eurekanet.org](http://www.eurekanet.org) and click on Contacts and send it by email.

**THANK YOU FOR THE UPDATE!**













**Taft College Check Register Report**

**01-September-18 through 30-September-18**

**FY 18-19**

78038409	09/04/2018	A00298951Macias, Jazmine S.	S0044481	11000	9526	150.00
78038410	09/04/2018	A00285320Magana, Daisy K.	S0044482	11000	9526	184.00
78038411	09/04/2018	A00292191Maher, Elizabeth R.	S0044483	11000	9526	230.00
78038412	09/04/2018	A00286378Martin, Christina L.	S0044484	11000	9526	1,000.00
78038413	09/04/2018	A00301896Martinez, Breana N.	S0044485	11000	9526	230.00
78038414	09/04/2018	A00288978Martinez, Milagros	S0044486	11000	9526	368.00
78038415	09/04/2018	A00283357McCuan, Jeffery S.	S0044487	11000	9526	230.00
78038416	09/04/2018	A00282302McDonald, Jessica V.	S0044488	11000	9526	1,000.00
78038417	09/04/2018	A00210665McDonald, Mary E.	S0044489	11000	9526	184.00
78038418	09/04/2018	A00299333McEwen, Tyler G.	S0044490	11000	9526	46.00
78038419	09/04/2018	A00296552McKinney, Ryan H.	S0044491	11000	9526	138.00
78038420	09/04/2018	A00283962Mechael, Lilian S.	S0044492	11000	9526	184.00
78038421	09/04/2018	A00275708Miller, Clemente	S0044493	11000	9526	46.00
78038422	09/04/2018	A00295065Molina, Rafael A.	S0044494	11000	9526	644.00
78038423	09/04/2018	A00016270Morenovilla, Martin E.	S0044495	11000	9526	184.00
78038424	09/04/2018	A00002933Morgan, Linda M.	S0044496	11000	9526	138.00
78038425	09/04/2018	A00290824Moseley, Jessica D.	S0044497	11000	9526	1,000.00
78038426	09/04/2018	A00302440Mountain, Michael S.	S0044498	11000	9526	184.00
78038427	09/04/2018	A00279362Neher, Kaylee D.	S0044499	11000	9526	218.00
78038428	09/04/2018	A00296440Nielsen, Timothy J.	S0044500	11000	9526	644.00
78038429	09/04/2018	A00282303Ojeda Yesca, Delfina	S0044501	11000	9526	862.00
78038430	09/04/2018	A00262578Pacheco, Elizabeth	S0044502	11000	9526	46.00
78038431	09/04/2018	A00301022Palmer, Brynn M.	S0044503	11000	9526	368.00
78038432	09/04/2018	A00255797Panjajom, Kaevalin	S0044504	11000	9526	46.00
78038433	09/04/2018	A00201241Payne, Aarron L.	S0044505	11000	9526	322.00
78038434	09/04/2018	A00291699Payne, Taylar N.	S0044506	11000	9526	69.00
78038435	09/04/2018	A00247058Perez, Beatris	S0044507	11000	9526	138.00
78038436	09/04/2018	A00286583Perez, Clarissa L.	S0044508	11000	9526	276.00
78038437	09/04/2018	A00300419Perez, Rigoberto G.	S0044509	11000	9526	138.00
78038438	09/04/2018	A00300424Perez, Thania J.	S0044510	11000	9526	230.00
78038439	09/04/2018	A00290817Pilgrim, Sierra D.	S0044511	11000	9526	857.40
78038440	09/04/2018	A00278267Powers, Bailey M.	S0044512	11000	9526	1,000.00
78038441	09/04/2018	A00300285Prendez, Aubree J.	S0044513	11000	9526	138.00
78038442	09/04/2018	A00280882Quebral-Strehle, Lauren E.	S0044514	11000	9526	138.00
78038443	09/04/2018	A00272484Quinonez, Kimberly	S0044515	11000	9526	400.00
78038444	09/04/2018	A00289174Ramirez, Alfonso D.	S0044516	11000	9526	138.00
78038445	09/04/2018	A00267030Raney, Drew M.	S0044517	11000	9526	184.00
78038446	09/04/2018	A00285844Ray, Nicolas A.	S0044518	11000	9526	138.00
78038447	09/04/2018	A00277123Ray, Priscella R.	S0044519	11000	9526	414.00
78038448	09/04/2018	A00239655Redfeairn, Bradly L.	S0044520	11000	9526	138.00
78038449	09/04/2018	A00272440Reed, Braiden A.	S0044521	11000	9526	500.00
78038450	09/04/2018	A00297713Reyes, Enrique R.	S0044522	11000	9526	1,000.00
78038451	09/04/2018	A00291457Rice, Jarred M.	S0044523	11000	9526	138.00
78038452	09/04/2018	A00265985Ritchie, Tajai L.	S0044524	11000	9526	184.00

**Taft College Check Register Report****01-September-18 through 30-September-18****FY 18-19**

78038453	09/04/2018	A00291345	Robertson, Joshua K.	S0044525	11000	9526	184.00
78038454	09/04/2018	A00273530	Rodriguez, Anthony	S0044526	11000	9526	230.00
78038455	09/04/2018	A00294485	Rodriguez, Jeanette	S0044527	11000	9526	414.00
78038456	09/04/2018	A00281000	Rodriguez, Jose	S0044528	11000	9526	192.00
78038457	09/04/2018	A00286374	Romo Rosales, Vania M.	S0044529	11000	9526	1,000.00
78038458	09/04/2018	A00297888	Rosales, Lorena	S0044530	11000	9526	1,000.00
78038459	09/04/2018	A00292824	Rosales Perez, Daisy	S0044531	11000	9526	1,000.00
78038460	09/04/2018	A00254318	Ruhangi, Mary W.	S0044532	11000	9526	184.00
78038461	09/04/2018	A00292350	Ruiz, Maria M.	S0044533	11000	9526	690.00
78038462	09/04/2018	A00296499	Ruiz, Patricia M.	S0044534	11000	9526	230.00
78038463	09/04/2018	A00107466	Ruiz de Orozco, Maria M.	S0044536	11000	9526	322.00
78038464	09/04/2018	A00278903	Ruiz Ramirez, Dafne A.	S0044535	11000	9526	138.00
78038465	09/04/2018	A00280021	Saldias, Trinity E.	S0044537	11000	9526	138.00
78038466	09/04/2018	A00280665	Sanabria Torres, Maria A.	S0044538	11000	9526	900.00
78038467	09/04/2018	A00294938	Sanchez, Kimberly A.	S0044539	11000	9526	184.00
78038468	09/04/2018	A00290344	Sanchez, Monica	S0044540	11000	9526	30.00
78038469	09/04/2018	A00288790	Sandhu, Gurkirt S.	S0044541	11000	9526	230.00
78038470	09/04/2018	A00295066	Sandoval Guzman, Maria S.	S0044542	11000	9526	184.00
78038471	09/04/2018	A00028475	Seymour, Erica	S0044543	11000	9526	46.00
78038472	09/04/2018	A00279394	Sharp, Jaycee E.	S0044544	11000	9526	1,000.00
78038473	09/04/2018	A00281442	Shelton, Paul G.	S0044545	11000	9526	184.00
78038474	09/04/2018	A00294729	Shy, Michael C.	S0044546	11000	9526	213.69
78038475	09/04/2018	A00297366	Silva Garcia, Rosa I.	S0044547	11000	9526	1,000.00
78038476	09/04/2018	A00280673	Snyder, Ashlan M.	S0044548	11000	9526	322.00
78038477	09/04/2018	A00296419	Solomon, Felicia M.	S0044549	11000	9526	1,034.10
78038478	09/04/2018	A00277833	Stephens, Terance E.	S0044550	11000	9526	138.00
78038479	09/04/2018	A00234061	Streeks, Candice M.	S0044551	11000	9526	460.00
78038480	09/04/2018	A00302424	Sugg, Michael L.	S0044552	11000	9526	253.00
78038481	09/04/2018	A00292313	Sweeny, Jack H.	S0044553	11000	9526	322.00
78038482	09/04/2018	A00297720	Talnenetz, Seth J.	S0044554	11000	9526	402.00
78038483	09/04/2018	A00286362	Torres, Enrique	S0044555	11000	9526	1,000.00
78038484	09/04/2018	A00294393	Turner, Lindsay P.	S0044556	11000	9526	402.00
78038485	09/04/2018	A00229594	Unruh, Moriah N.	S0044557	11000	9526	184.00
78038486	09/04/2018	A00282288	Urias, Abel	S0044558	11000	9526	1,000.00
78038487	09/04/2018	A00289755	Valdez, Priscilla	S0044559	11000	9526	276.00
78038488	09/04/2018	A00295040	Valenzuela, Santa I.	S0044560	11000	9526	138.00
78038489	09/04/2018	A00291576	Vasquez, Karina D.	S0044561	11000	9526	184.00
78038490	09/04/2018	A00284057	Villatoro, Ilis K.	S0044562	11000	9526	184.00
78038491	09/04/2018	A00292306	Wedemeyer, Stacy E.	S0044563	11000	9526	276.00
78038492	09/04/2018	A00203617	Wheat, Harry L.	S0044564	11000	9526	184.00
78038493	09/04/2018	A00077138	Wheeler, Jessica	S0044565	11000	9526	138.00
78038494	09/04/2018	A00271472	Wilderson, Crysta M.	S0044566	11000	9526	276.00
78038495	09/04/2018	A00037883	Willhelm, Bryce	S0044567	11000	9526	276.00
78038496	09/04/2018	A00203522	Willhelm, Tess M.	S0044568	11000	9526	276.00





**Taft College Check Register Report****01-September-18 through 30-September-18****FY 18-19**

78038546	09/12/2018	A00271101Mid-Hudson Photo ID	I0055147	126734	11000	202	4310	60100	89.71
78038547	09/12/2018	A00278548Natural History Museum	I0055130	110218	11000	209	5740	04011	350.00
78038548	09/12/2018	A00205869NISOD	I0055202	2385	12571	411	5210	67300	995.00
78038549	09/12/2018	A00200498Office Depot	I0055158	18610066	11000	352	4310	69610	108.46
			I0055203	16673401	11000	411	4310	67300	95.92
					11000	411	4310	67300	2.99
78038550	09/12/2018	A00200522Pepsi-Cola Company	I0055139	04084605	32000	422	4410	69400	2,596.28
78038551	09/12/2018	A00200536Praxair Distribution, Inc.	I0055144	84496403	11000	205	4311	12042	1,281.18
			I0055145	84664061	11000	205	4311	12042	140.27
78038552	09/12/2018	A00200539Proctor & Gamble	I0055179	37058214	11000	205	4311	12042	45.00
78038553	09/12/2018	A00285838Sammy's Detail	I0055148	00743	11000	432	5632	67703	285.00
			I0055193	00729	11000	432	5632	67703	135.00
78038554	09/12/2018	A00300361Smith, Jamie R.	I0055195	091018	11000	110	5990	66003	12,523.74
78038555	09/12/2018	A00200393Sparkletts	I0055123	082318	11000	301	5810	64500	128.03
78038556	09/12/2018	A00200393Sparkletts	I0055127	08/23/18	11000	113	4310	67801	88.07
78038557	09/12/2018	A00200393Sparkletts	I0055156	07.26.18	11000	205	4311	12042	60.89
78038558	09/12/2018	A00200393Sparkletts	I0055169	081718	12560	223	4310	09565	213.15
78038559	09/12/2018	A00303291Sport & Cycle, Inc.	I0055120	214214	11000	209	4311	08352	2,599.59
78038560	09/12/2018	A00237176SSD Systems	I0055160	472003-S	11000	205	5880	12042	29.60
78038561	09/12/2018	A00200400Stinson's	I0055136	809227-0	11000	113	4310	67801	171.56
			I0055137	809290-1	11000	113	4318	67801	803.99
			I0055206	808378-0	11000	209	4318	15017	66.36
					11000	209	4318	15017	230.90
78038562	09/12/2018	A00275935Supplyworks	I0055192	44892147	11000	431	4310	65300	252.40
78038563	09/12/2018	A00200417Sysco Food Service of Ventur	I0055111	17958929	33429	310	4410	69200	2,392.43
			I0055128	17959563	32000	422	4410	69400	7,995.98
					32000	422	4411	69400	1,813.33
					32000	422	4411	69400	586.58
78038564	09/12/2018	A00200423Taft City School District	I0055117	19-016	11000	432	4310	67703	415.76
					11000	432	5850	67703	20.00
					11000	432	5632	67703	100.50
					11000	352	4310	69610	6.00
					11000	352	5632	69610	100.50
78038565	09/12/2018	A00200425Taft College	I0055150	8/12/18	31000	423	7130	69100	4,440.00
78038566	09/12/2018	A00200425Taft College	I0055176	081318	31000	423	7130	69100	1,740.00
78038567	09/12/2018	A00200862Taft College Bookstore	I0055162	7708	12000	303	4310	64300	246.60
78038568	09/12/2018	A00200862Taft College Bookstore	I0055164	8967	11000	352	5940	69610	12.92
78038569	09/12/2018	A00200862Taft College Bookstore	I0055181	7067	12000	303	7604	64300	2,006.75
78038570	09/12/2018	A00200862Taft College Bookstore	I0055207	7816	12551	353	4310	64600	34.26
78038571	09/12/2018	A00200426Taft College Cafeteria	I0055199	082718	32000	422	4410	69400	39.96
78038572	09/12/2018	A00200432Taft Union High School	I0055163	19-001	11000	352	5611	69612	2,500.00
					11000	352	5611	69613	2,500.00
78038573	09/12/2018	A00200282True Value Home Center	I0055187	392714	33428	310	4310	69200	288.46
			I0055196	392445	11000	431	4310	65100	683.79









Taft College Check Register Report

01-September-18 through 30-September-18

FY 18-19

						33428	310	5641	69200	362.35
						39000	314	5641	64991	1,644.67
						11000	401	5641	67200	412.73
						12551	353	5641	64600	414.32
						11000	301	5641	64500	414.32
						11000	302	5641	63100	414.32
						11000	358	5641	62100	414.32
						11000	110	5641	66003	47.11
						11000	202	5641	60100	47.11
						11000	114	5641	66005	47.11
						11000	113	5641	67801	300.08
						11000	431	5641	65100	474.63
						11000	202	5641	60100	67.30
						31000	423	5641	69100	563.73
78038671	09/19/2018	A00286374	Romo Rosales, Vania M.	S0045622		11000		9526		300.00
78038672	09/19/2018	A00297888	Rosales, Lorena	S0045623		11000		9526		300.00
78038673	09/19/2018	A00292824	Rosales Perez, Daisy	S0045624		11000		9526		300.00
78038674	09/19/2018	A00296585	Rowan, Kayla M.	S0045625		11000		9526		300.00
78038675	09/19/2018	A00285838	Sammy's Detail	I0055266	00747	11000	202	5890	60103	120.00
				I0055322	713	11000	432	5632	67703	265.00
78038676	09/19/2018	A00271094	Sanders, Cinnamon S.	S0044284		11000		9526		184.00
78038677	09/19/2018	A00220442	Serban Sound & Communication	I0055291	11217	11000	113	5632	67801	900.00
						11000	113	4312	67801	21.45
78038678	09/19/2018	A00297366	Silva Garcia, Rosa I.	S0045626		11000		9526		300.00
78038679	09/19/2018	A00234793	Southwest Signs	I0055230	17700.	31000	423	4310	69100	28.00
78038680	09/19/2018	A00200393	Sparkletts	I0055224	08-23-18	11000	411	5641	67300	95.06
78038681	09/19/2018	A00200393	Sparkletts	I0055257	090618	11000	306	4310	49306	63.60
78038682	09/19/2018	A00200393	Sparkletts	I0055262	081618	11000	209	4310	49999	18.15
78038683	09/19/2018	A00237176	SSD Systems	I0055260	1347432-	31000	423	5880	69100	59.34
78038684	09/19/2018	A00201787	Standard Insurance Company	I0055221	SEP 18	11000	411	3410	67300	460.04
						11000	411	3420	67300	1,198.96
78038685	09/19/2018	A00294299	Stewart, Emily Y.	S0045627		11000		9526		300.00
78038686	09/19/2018	A00287260	Stinson Stationers Inc.	I0055282	809572-0	11000	421	4318	67704	90.95
78038687	09/19/2018	A00200400	Stinson's	I0055249	810484-0	11000	209	4318	04011	57.60
						11000	302	4318	64500	244.00
78038687	09/19/2018	A00200400	Stinson's	I0055275	811331-0	11000	353	4318	64600	180.79
				I0055277	811661-0	11000	353	4318	64600	66.36
						11000	353	4318	64600	230.90
				I0055287	811057-0	11000	202	4318	60100	91.75
						11000	202	4318	60100	368.54
						12434	219	4318	17010	262.22
				I0055292	810838-0	11000	353	4318	64600	149.88
78038688	09/19/2018	A00200417	Sysco Food Service of Ventur	I0055246	17960395	32000	422	4410	69400	8,764.69
						32000	422	4411	69400	1,425.00





**Taft College Check Register Report**

**01-September-18 through 30-September-18**

**FY 18-19**

78038747	09/24/2018	A00200472Scantron Corporation	I0055372	6387107	31000	423	4310	69100	1,804.80
					31000	423	5940	69100	67.30
78038748	09/24/2018	A00303183Southern Computer Warehouse,	I0055353	00052709	11000	202	6412	60200	3,052.90
78038749	09/24/2018	A00200393Sparkletts	I0055363	083118	31000	423	4321	69100	15.99
78038750	09/24/2018	A00277399Sundgren, Lori A.	I0055348	11076158	11495	216	5710	61900	50.00
78038751	09/24/2018	A00200862Taft College Bookstore	I0055376	9291	11000	352	5940	69610	10.41
78038752	09/24/2018	A00200078The Bank of New York	I0055329	252-2128	11000	401	7120	67200	795.00
78038753	09/24/2018	A00200282True Value Home Center	I0055351	396262	12558	223	4310	09565	102.36
78038754	09/24/2018	A00234013U-Cart Cement, Inc.	I0055357	008-348	11000	431	4317	65100	135.00
78038755	09/24/2018	A00200284U.S. Foods	I0055360	5275815	32000	422	4410	69400	6,720.73
					32000	422	4411	69400	251.28
78038756	09/24/2018	A00205963Valencia, Leovi M.	I0055343	082818	11000	421	5710	67200	39.83
78038757	09/24/2018	A00200827W.W. Norton & Company Inc.	I0055371	676892	31000	423	4110	69100	100.00
					31000	423	5940	69100	302.45
78038758	09/24/2018	A00200355West Kern Water District	I0055339	091218	11000	431	5810	65700	452.65
					39000	314	5810	64991	114.59
78038759	09/24/2018	A00275443WestAir Gases & Equipment In	I0055352	10747532	12558	223	4311	09565	9.93
78038760	09/25/2018	A00014447Cadena, Amy M.	S0045636		11000		9526		14,700.00
78038761	09/25/2018	A00292336Dobbs, Alex M.	S0045637		11000		9526		138.00
78038762	09/25/2018	A00283227Gowdy, Christopher D.	S0045638		11000		9526		690.00
78038763	09/25/2018	A00282282Manibusan, Jaime A.	S0045639		11000		9526		138.00
78038764	09/25/2018	A00040499Nearn, Mark	S0045640		11000		9526		46.00
78038765	09/25/2018	A00298202Rivera, Joseph M.	S0045642		11000		9526		644.00
78038766	09/25/2018	A00294284Roy, Tristan A.	S0045641		11000		9526		562.50
								=====	
								BANK TOTAL	775,401.62

Taft College Purchase Order Activity Report 1-September-2018 through 30-September-2018

FY 18-19

USER ID	ACTIVITY DATE	VENDOR NUMBER	VENDOR NAME	PURCHASE ORDER NUMBER	PURCHASE ORDER DATE	REQ. DATE	PURCHASE ORDER AMOUNT	CL	C	A	
AOMEGA	09/11/2018	A00200729	Landauer, Inc.	P0049085	08/30/2018	08/30/2018	\$849.88				
	09/17/2018	A00200122	Calif. Dept. of Health Services	P0049161	09/11/2018	09/11/2018	\$944.00				
		A00200498	Office Depot	P0049124	09/06/2018	09/06/2018	\$31.02				
		A00200655	Henry Schein, Inc.	P0049132	09/06/2018	09/06/2018	\$163.14				
		A00202355	Hu-Friedy	P0049156	09/11/2018	09/11/2018	\$681.39				
		A00229200	Deluxe Corporation	P0049158	09/11/2018	09/11/2018	\$600.55				
		A00280536	Kern Trophies	P0049168	09/11/2018	09/11/2018	\$9.12				
		A00200516	Patterson Dental Supply, Inc	P0049204	09/13/2018	09/13/2018	\$1,229.53				
		A00200655	Henry Schein, Inc.	P0049207	09/13/2018	09/13/2018	\$98.68				
	09/18/2018	A00200393	Sparkletts	P0049222	09/13/2018	09/13/2018	\$40.88				
		A00200655	Henry Schein, Inc.	P0049223	09/13/2018	09/13/2018	\$935.24				
		A00200498	Office Depot	P0049236	09/14/2018	09/14/2018	\$6.00				
		A00200655	Henry Schein, Inc.	P0049233	09/14/2018	09/14/2018	\$815.03				
	09/27/2018	A00200536	Praxair Distribution, Inc.	P0049342	09/27/2018	09/27/2018	\$489.99				
	09/28/2018	A00200655	Henry Schein, Inc.	P0049353	09/28/2018	09/28/2018	\$110.60				
		A00300363	EMD Millipore Corp.	P0049351	09/28/2018	09/28/2018	\$182.30				
		A00200655	Henry Schein, Inc.	P0049316	09/25/2018	09/25/2018	\$1,263.89				
				P0049325	09/26/2018	09/26/2018	\$140.39				
								-----			
								TOTAL USER			\$8,591.63
ARAMIREZ	09/26/2018	A00200338	Verizon Wireless	P0049338	09/26/2018	09/26/2018	\$114.03				
								-----			
							TOTAL USER			\$114.03	
DDURAN	09/21/2018	A00200419	T.C. Clearing Account	P0049293	09/20/2018	09/20/2018	\$1,301.84				
	09/26/2018	A00200161	CDW-G	P0049307	09/24/2018	09/24/2018	\$1,684.79				
								-----			
							TOTAL USER			\$2,986.63	
DHICKS	09/04/2018	A00200040	American Business Machines	P0049101	09/04/2018	09/04/2018	\$202.70				
	09/10/2018	A00200200	Computerland of Silicon Vall	P0049096	08/31/2018	08/31/2018	\$162.00				
		A00200400	Stinson's	P0049089	08/30/2018	08/30/2018	\$149.89				
				P0049102	09/04/2018	09/04/2018	\$180.79				
				P0049112	09/05/2018	09/05/2018	\$297.25				
		A00231833	Ray A. Morgan Company Inc.	P0048831	08/14/2018	08/14/2018	\$5,677.11				
	09/11/2018	A00200161	CDW-G	P0049061	08/29/2018	08/29/2018	\$493.58				
		A00200200	Computerland of Silicon Vall	P0049063	08/29/2018	08/29/2018	\$81.00				
		A00220442	Serban Sound & Communication	P0049079	08/30/2018	08/30/2018	\$921.45				
		A00266215	Monoprice Inc.	P0049088	08/30/2018	08/30/2018	\$35.28				

# Taft College Purchase Order Activity Report 1-September-2018 through 30-September-2018

FY 18-19

USER ID	ACTIVITY DATE	VENDOR NUMBER NAME	PURCHASE ORDER NUMBER DATE	REQ. DATE	PURCHASE ORDER AMOUNT	CL C A
		A00108728 Issue Trak, Inc	P0049146	09/10/2018	09/10/2018	\$1,725.00
		A00200161 CDW-G	P0049098	08/31/2018	08/31/2018	\$759.33
		A00200400 Stinson's	P0049097	08/31/2018	08/31/2018	\$722.52
	09/12/2018	A00200200 Computerland of Silicon Vall	P0049106	09/05/2018	09/05/2018	\$81.00
		A00200400 Stinson's	P0049171	09/11/2018	09/11/2018	\$75.37
	09/13/2018	A00264649 Convergent Technologies, LLC	P0049172	09/11/2018	09/11/2018	\$1,122.58
			P0049174	09/11/2018	09/11/2018	\$1,880.74
	09/14/2018	A00200400 Stinson's	P0049226	09/13/2018	09/13/2018	\$731.99
	09/17/2018	A00200161 CDW-G	P0049167	09/11/2018	09/11/2018	\$118.69
		A00200200 Computerland of Silicon Vall	P0049165	09/11/2018	09/11/2018	\$360.00
	09/20/2018	A00200400 Stinson's	P0049275	09/19/2018	09/19/2018	\$793.97
	09/28/2018	A00200400 Stinson's	P0049355	09/28/2018	09/28/2018	\$214.60
		A00200161 CDW-G	P0049339	09/27/2018	09/27/2018	\$127.72
		A00200200 Computerland of Silicon Vall	P0049314	09/25/2018	09/25/2018	\$81.00
		A00200400 Stinson's	P0049265	09/18/2018	09/18/2018	\$135.19
			P0049321	09/25/2018	09/25/2018	\$658.07
			P0049337	09/26/2018	09/26/2018	\$91.12
			P0049345	09/27/2018	09/27/2018	\$78.35
		A00264649 Convergent Technologies, LLC	P0049322	09/25/2018	09/25/2018	\$1,176.00
					TOTAL USER	\$19,134.29
DRIOS	09/11/2018	A00200356 West Side Recreation & Park	P0048896	08/17/2018	08/17/2018	\$3,000.00
		A00000456 Uribe, Jose	P0049108	09/05/2018	09/05/2018	\$90.00
	09/17/2018	A00200063 Austin's Pest Control, Inc.	P0049157	09/11/2018	09/11/2018	\$1,000.00
		A00200355 West Kern Water District	P0048995	08/24/2018	08/24/2018	\$400.00
			P0049138	09/07/2018	09/07/2018	\$500.00
		A00200498 Office Depot	P0049008	08/27/2018	08/27/2018	\$1,500.00
		A00292936 Albertson's LLC	P0049074	08/30/2018	08/30/2018	\$8,000.00
		A00200109 Brown & Reich Petroleum, Inc	P0049139	09/07/2018	09/07/2018	\$7,000.00
		A00200355 West Kern Water District	P0048701	08/03/2018	08/03/2018	\$5.10
		A00200680 J & L Locksmithing	P0049193	09/12/2018	09/12/2018	\$500.00
		A00202445 AT&T Mobility	P0049137	09/07/2018	09/07/2018	\$3,000.00
		A00063469 White, Billy D.	P0049211	09/13/2018	09/13/2018	\$12,700.00
		A00075823 Binkley, Everett L.	P0049210	09/13/2018	09/13/2018	\$15,800.00
		A00265229 DK&M Property	P0049208	09/13/2018	09/13/2018	\$30,500.00
		A00271491 Watkins, Sherrie D.	P0049212	09/13/2018	09/13/2018	\$11,900.00
	09/25/2018	A00200327 US Air Conditioning	P0049276	09/20/2018	09/20/2018	\$1,122.84
	09/28/2018	A00073955 White, Brian L.	P0049323	09/26/2018	09/26/2018	\$12,700.00
		A00200017 A.P.I. Plumbing	P0049305	09/24/2018	09/24/2018	\$800.00
		A00200181 City of Taft	P0049246	09/17/2018	09/17/2018	\$6,000.00
		A00200282 True Value Home Center	P0049194	09/12/2018	09/12/2018	\$800.00



# Taft College Purchase Order Activity Report 1-September-2018 through 30-September-2018

FY 18-19

USER ID	ACTIVITY DATE	VENDOR NUMBER	VENDOR NAME	PURCHASE ORDER NUMBER	PURCHASE ORDER DATE	REQ. DATE	PURCHASE ORDER AMOUNT	CL C A	
HCASH	09/11/2018	A00200862	Taft College Bookstore	P0049118	08/30/2018	08/30/2018	\$92.93		
				P0049119	08/22/2018	08/22/2018	\$530.73		
							-----		
							TOTAL USER	\$623.66	
JEDMAISTON	09/10/2018	A00200282	True Value Home Center	P0049114	09/06/2018	09/06/2018	\$8.56		
				A00200655	08/30/2018	08/30/2018	\$84.78		
				A00200502	09/06/2018	09/06/2018	\$1,540.00		
	09/11/2018	A00231833	Ray A. Morgan Company Inc.	P0049095	08/31/2018	08/31/2018	\$106.23		
	09/21/2018	A00200498	Office Depot	P0049290	09/20/2018	09/20/2018	\$73.24		
	09/24/2018	A00200862	Taft College Bookstore	P0049196	09/12/2018	09/12/2018	\$10.41		
	09/26/2018	A00200282	True Value Home Center	P0049330	09/26/2018	09/26/2018	\$21.33		
				A00200502	09/26/2018	09/26/2018	\$1,230.00		
	09/28/2018	A00231833	Ray A. Morgan Company Inc.	P0049319	09/25/2018	09/25/2018	\$83.32		
				A00200502	09/13/2018	09/13/2018	\$5,780.00		
								-----	
								TOTAL USER	\$13,807.87
JGARRETT	09/10/2018	A00200393	Sparkletts	P0049136	09/07/2018	09/07/2018	\$63.60		
				A00200595	09/05/2018	09/05/2018	\$2,161.25		
	09/12/2018	A00200029	ACT Asset Program	P0049159	09/11/2018	09/11/2018	\$24.00		
				A00200498	09/11/2018	09/11/2018	\$58.66		
	09/24/2018	A00200279	Educational Testing Service	P0049273	09/19/2018	09/19/2018	\$520.00		
				A00200498	09/13/2018	09/13/2018	\$70.95		
	09/27/2018	A00200498	Office Depot	P0049329	09/26/2018	09/26/2018	\$59.04		
								-----	
							TOTAL USER	\$2,957.50	
JMADDING	09/04/2018	A00200498	Office Depot	P0049045	08/29/2018	08/29/2018	\$45.57		
	09/10/2018	A00200069	Bakersfield Californian	P0049152	09/10/2018	09/10/2018	\$249.07		
	09/13/2018	A00264649	Convergint Technologies, LLC	P0049149	09/10/2018	09/10/2018	\$7,134.52		
				A00200773	08/23/2018	08/23/2018	\$99.79		
	09/17/2018	A00200308	Federal Express Corporation	P0049250	09/17/2018	09/17/2018	\$95.74		
				A00200862	09/10/2018	09/10/2018	\$89,053.09		
	09/18/2018	A00200052	AP Architects	P0049253	09/17/2018	09/17/2018	\$24,029.29		
				A00200078	09/18/2018	09/18/2018	\$795.00		
				A00200222	09/17/2018	09/17/2018	\$246.00		
				A00200862	09/17/2018	09/17/2018	\$16.08		
							-----		
							TOTAL USER	\$76.13	



# Taft College Purchase Order Activity Report 1-September-2018 through 30-September-2018

FY 18-19

USER ID	ACTIVITY DATE	VENDOR NUMBER	VENDOR NAME	PURCHASE ORDER NUMBER	PURCHASE ORDER DATE	REQ. DATE	PURCHASE ORDER AMOUNT	CL	C	A
		A00303419	Clear Blue Energy Corporatio	P0049260	09/18/2018	09/18/2018	\$10,589.34			
	09/24/2018	A00200308	Federal Express Corporation	P0049295	09/21/2018	09/21/2018	\$49.26			
				P0049249	09/17/2018	09/17/2018	\$28.57			
	09/25/2018	A00287260	Stinson Stationers Inc.	P0049306	09/24/2018	09/24/2018	\$479.56			
	09/26/2018	A00270674	Public Agency Law Group	P0049332	09/26/2018	09/26/2018	\$13,469.14			
	09/28/2018	A00266450	USBank	P0049334	09/26/2018	09/26/2018	\$1,455,665.63			
		A00200308	Federal Express Corporation	P0049348	09/28/2018	09/28/2018	\$29.39			
							-----			
							TOTAL USER			\$1,602,151.17
JROBERTSON	09/11/2018	A00200220	Cutrona, Angelo	P0049154	09/10/2018	09/10/2018	\$905.35			
		A00200348	Ware, Thomas B.	P0049133	09/06/2018	09/06/2018	\$500.00			
	09/17/2018	A00200498	Office Depot	P0049182	09/12/2018	09/12/2018	\$213.01			
				P0049183	09/12/2018	09/12/2018	\$69.51			
				P0049184	09/12/2018	09/12/2018	\$50.31			
		A00200502	Orange Belt Stages	P0049166	09/11/2018	09/11/2018	\$1,658.00			
	09/20/2018	A00200498	Office Depot	P0049274	09/19/2018	09/19/2018	\$57.72			
	09/28/2018	A00200764	Martinez, Julian	P0049317	09/25/2018	09/25/2018	\$11.25			
							-----			
							TOTAL USER			\$3,465.15
JROTHGEB	09/11/2018	A00275443	WestAir Gases & Equipment In	P0049151	09/10/2018	09/10/2018	\$435.08			
		A00285838	Sammy's Detail	P0049150	09/10/2018	09/10/2018	\$120.00			
	09/17/2018	A00200508	P. G. & E.	P0049155	09/11/2018	09/11/2018	\$552.59			
		A00200950	Furman, Tori J.	P0049191	09/12/2018	09/12/2018	\$1,302.70			
		A00200282	True Value Home Center	P0049215	09/13/2018	09/13/2018	\$102.36			
		A00275443	WestAir Gases & Equipment In	P0049214	09/13/2018	09/13/2018	\$9.93			
	09/19/2018	A00231833	Ray A. Morgan Company Inc.	P0049267	09/18/2018	09/18/2018	\$121.38			
	09/24/2018	A00277845	Double D Cleaning Service	P0049296	09/21/2018	09/21/2018	\$240.00			
	09/28/2018	A00280086	Rothgeb, Julie J.	P0049352	09/28/2018	09/28/2018	\$441.45			
		A00200282	True Value Home Center	P0049343	09/27/2018	09/27/2018	\$16.08			
		A00200355	West Kern Water District	P0049303	09/24/2018	09/24/2018	\$100.40			
		A00200498	Office Depot	P0049327	09/26/2018	09/26/2018	\$222.12			
							-----			
							TOTAL USER			\$3,664.09
KEHELMS	09/07/2018	A00292869	Colorado Nut Company, Inc.	P0049116	09/06/2018	09/06/2018	\$167.49			
	09/13/2018	A00292796	Safe 1 Credit Union	P0049117	09/06/2018	09/06/2018	\$355.96			
		A00200498	Office Depot	P0049177	09/12/2018	09/12/2018	\$123.75			
		A00258705	El Dorado Trading Group	P0049178	09/12/2018	09/12/2018	\$1,522.26			
		A00200127	California Dept. of Educatio	P0049202	09/13/2018	09/13/2018	\$3,017.30			

# Taft College Purchase Order Activity Report 1-September-2018 through 30-September-2018

FY 18-19

USER ID	ACTIVITY DATE	VENDOR NUMBER	VENDOR NAME	PURCHASE ORDER NUMBER	PURCHASE ORDER DATE	REQ. DATE	PURCHASE ORDER AMOUNT	CL	C	A
		A00200472	Scantron Corporation	P0049200	09/13/2018	09/13/2018				\$1,872.10
		A00200827	W.W. Norton & Company Inc.	P0049198	09/13/2018	09/13/2018				\$402.45
		A00258703	College House	P0049205	09/13/2018	09/13/2018				\$1,009.96
		A00274574	Penguin Random House LLC	P0049209	09/13/2018	09/13/2018				\$745.71
	09/14/2018	A00200016	4Imprint	P0049220	09/13/2018	09/13/2018				\$814.54
		A00200521	Pens Etc.	P0049216	09/13/2018	09/13/2018				\$413.27
		A00200522	Pepsi-Cola Company	P0049219	09/13/2018	09/13/2018				\$128.75
		A00258705	El Dorado Trading Group	P0049218	09/13/2018	09/13/2018				\$175.00
		A00292925	indiCo, LLC	P0049221	09/13/2018	09/13/2018				\$350.53
		A00200555	McGraw-Hill	P0049235	09/14/2018	09/14/2018				\$10.98
		A00200721	Kiwanis Club of Taft	P0049230	09/14/2018	09/14/2018				\$656.50
		A00201685	Cengage Learning	P0049229	09/14/2018	09/14/2018				\$172.91
		A00234793	Southwest Signs	P0049232	09/14/2018	09/14/2018				\$1,374.50
		A00252523	Oak Hall Cap and Gown	P0049234	09/14/2018	09/14/2018				\$326.94
		A00293918	A&B Athletics	P0049228	09/14/2018	09/14/2018				\$2,949.70
	09/26/2018	A00200106	Bright House Ad Sales	P0049115	09/06/2018	09/06/2018				\$1,400.00
							TOTAL USER			\$17,990.60
KHELMS	09/18/2018	A00200282	True Value Home Center	P0049245	09/17/2018	09/17/2018				\$148.12
		A00200498	Office Depot	P0049239	09/17/2018	09/17/2018				\$130.95
		A00201051	Central Sanitary Supply	P0049240	09/17/2018	09/17/2018				\$32.94
		A00244581	Independent Fire and Safety,	P0049243	09/17/2018	09/17/2018				\$337.00
		A00256341	Terminix	P0049242	09/17/2018	09/17/2018				\$418.00
	09/21/2018	A00096146	Lemus, Everardo I.	P0049287	09/20/2018	09/20/2018				\$76.00
		A00200715	Kern Electric Distributors	P0049282	09/20/2018	09/20/2018				\$78.28
		A00201051	Central Sanitary Supply	P0049281	09/20/2018	09/20/2018				\$44.87
		A00201160	Hall Silveira, Margaret M.	P0049283	09/20/2018	09/20/2018				\$10.00
				P0049285	09/20/2018	09/20/2018				\$30.00
		A00237176	SSD Systems	P0049280	09/20/2018	09/20/2018				\$151.38
							TOTAL USER			\$1,457.54
MBLANCO	09/10/2018	A00200154	CCCCSSAA	P0048921	08/20/2018	08/20/2018				\$300.00
		A00237331	Dumbrigue, Joanne Lucille Va	P0049126	09/06/2018	09/06/2018				\$29.97
		A00271247	Mendenhall, Janis Lee.	P0049053	08/29/2018	08/29/2018				\$153.43
				P0049054	08/29/2018	08/29/2018				\$338.49
		A00283101	Dumont Printing, Inc.	P0049142	09/07/2018	09/07/2018				\$77.17
		A00292978	Long, Brittany Kaye.	P0049002	08/24/2018	08/24/2018				\$85.00
		A00303321	Potter, Mark R.	P0049129	09/06/2018	09/06/2018				\$2,250.00
	09/12/2018	A00200135	CAPED	P0049134	09/06/2018	09/06/2018				\$595.00
		A00078087	Garza, Jose T.	P0049144	09/07/2018	09/07/2018				\$85.00
		A00200498	Office Depot	P0049145	09/07/2018	09/07/2018				\$54.49

**Taft College Purchase Order Activity Report 1-September-2018 through 30-September-2018**

**FY 18-19**

USER ID	ACTIVITY DATE	VENDOR		PURCHASE ORDER		PURCHASE ORDER AMOUNT	CL	C	A
		NUMBER	NAME	NUMBER	DATE				
		A00279208	Alvarez, Veronica	P0049143	09/07/2018	09/07/2018			\$85.00
		A00200656	Jacobi, Victoria J.	P0049173	09/11/2018	09/11/2018			\$146.00
		A00202280	Chaidez, Joell C.	P0049176	09/11/2018	09/11/2018			\$346.42
		A00200656	Jacobi, Victoria J.	P0049190	09/12/2018	09/12/2018			\$145.80
	09/13/2018	A00285849	Garcia, Alanah Marie.	P0049225	09/13/2018	09/13/2018			\$85.00
		A00202280	Chaidez, Joell C.	P0049175	09/11/2018	09/11/2018			\$1,115.74
	09/17/2018	A00277399	Sundgren, Lori Anne.	P0049169	09/11/2018	09/11/2018			\$50.00
				P0049170	09/11/2018	09/11/2018			\$574.35
	09/21/2018	A00299324	Strobel, Jennifer	P0049297	09/21/2018	09/21/2018			\$300.00
				P0049298	09/21/2018	09/21/2018			\$202.53
	09/24/2018	A00283101	Dumont Printing, Inc.	P0049311	09/24/2018	09/24/2018			\$133.55
		A00200498	Office Depot	P0049261	09/18/2018	09/18/2018			\$271.46
		A00200771	Altenhofel, Jennifer L.	P0049241	09/17/2018	09/17/2018			\$445.94
		A00202280	Chaidez, Joell C.	P0049302	09/21/2018	09/21/2018			\$790.05
		A00205648	Payne, Breanna La'Nee.	P0049252	09/17/2018	09/17/2018			\$514.07
		A00302532	Martinez, Windy	P0049301	09/21/2018	09/21/2018			\$353.20
	09/25/2018	A00294583	Brown, Malissa Marie.	P0049313	09/25/2018	09/25/2018			\$85.00
		A00025485	Alfaro, Antonio Gonzales.	P0049192	09/12/2018	09/12/2018			\$1,061.94
		A00303163	Matchware Inc.	P0049266	09/18/2018	09/18/2018			\$20,000.00
	09/26/2018	A00211077	Strata Information Group	P0049333	09/26/2018	09/26/2018			\$4,891.75
	09/27/2018	A00200076	Bandy, Ingrun K.	P0049244	09/17/2018	09/17/2018			\$300.00
		A00200442	Thompson, Tony M.	P0049257	09/17/2018	09/17/2018			\$70.00
		A00237331	Dumbrigue, Joanne Lucille Va	P0049299	09/21/2018	09/21/2018			\$49.89
		A00286446	Balason, Severo	P0049335	09/26/2018	09/26/2018			\$19.83
									-----
						TOTAL USER			\$36,006.07
MTOFTE	09/17/2018	A00210378	Grey House Publishing	P0049231	09/14/2018	09/14/2018			\$2,094.59
	09/19/2018	A00200119	C.A. Reding Company, Inc.	P0049272	09/19/2018	09/19/2018			\$1,286.60
	09/28/2018	A00200213	Council of Chief Librarians	P0049354	09/28/2018	09/28/2018			\$150.00
		A00200222	Daily Midway Driller	P0049336	09/26/2018	09/26/2018			\$67.60
									-----
						TOTAL USER			\$3,598.79
MWHITE	09/05/2018	A00234013	U-Card Cement, Inc.	P0049105	09/05/2018	09/05/2018			\$135.00
	09/07/2018	A00200017	A.P.I. Plumbing	P0049128	09/06/2018	09/06/2018			\$520.97
		A00200228	Dave's Glass Shop	P0049130	09/06/2018	09/06/2018			\$305.63
		A00200431	Taft Plumbing Co., Inc.	P0049131	09/06/2018	09/06/2018			\$1,546.00
		A00244581	Independent Fire and Safety,	P0049110	09/05/2018	09/05/2018			\$1,125.00
		A00293117	Michael Flooring Inc.	P0049113	09/06/2018	09/06/2018			\$12,845.18
	09/13/2018	A00200423	Taft City School District	P0049186	09/12/2018	09/12/2018			\$635.95
		A00200620	Geary Pacific Supply	P0049181	09/12/2018	09/12/2018			\$265.91

# Taft College Purchase Order Activity Report 1-September-2018 through 30-September-2018

FY 18-19

USER ID	ACTIVITY DATE	VENDOR		PURCHASE ORDER		PURCHASE ORDER AMOUNT	CL	C	A
		NUMBER	NAME	NUMBER	DATE				
		A00202335	Fastenal Industrial & Constr	P0049180	09/12/2018	09/12/2018			\$132.11
		A00200023	Abate-A-Weed	P0049187	09/12/2018	09/12/2018			\$460.10
		A00200254	Don's Tree Service	P0049188	09/12/2018	09/12/2018			\$1,780.00
	09/14/2018	A00201081	Westside Waste Management Co	P0049227	09/14/2018	09/14/2018			\$850.72
	09/21/2018	A00200423	Taft City School District	P0049292	09/20/2018	09/20/2018			\$363.36
		A00200536	Praxair Distribution, Inc.	P0049286	09/20/2018	09/20/2018			\$38.50
		A00201122	Home Depot Credit Services	P0049294	09/21/2018	09/21/2018			\$192.47
		A00273104	Jaguar Wrought Iron Inc.	P0049284	09/20/2018	09/20/2018			\$1,900.00
	09/24/2018	A00200282	True Value Home Center	P0049179	09/12/2018	09/12/2018			\$1,688.68
	09/28/2018	A00200023	Abate-A-Weed	P0049340	09/27/2018	09/27/2018			\$66.49
									-----
						TOTAL USER			\$24,852.07
MZERMENO	09/12/2018	A00201143	Brown, Elizabeth J.	P0049125	09/06/2018	09/06/2018			\$482.63
	09/25/2018	A00255627	Compansol	P0049195	09/12/2018	09/12/2018			\$1,705.28
									-----
						TOTAL USER			\$2,187.91
RWELBORN	09/24/2018	A00200498	Office Depot	P0049268	09/18/2018	09/18/2018			\$218.47
	09/28/2018	A00303443	CampusLogic, Inc.	P0049291	09/20/2018	09/20/2018			\$30,500.00
									-----
						TOTAL USER			\$30,718.47
SCRISS	09/17/2018	A00200439	Freitas, Sherrie D.	P0049160	09/11/2018	09/11/2018			\$514.80
	09/19/2018	A00244039	DB & Company	P0049263	09/18/2018	09/18/2018			\$193.05
		A00280536	Kern Trophies	P0049264	09/18/2018	09/18/2018			\$12.87
		A00294618	McNeil and Associates, LLC	P0049262	09/18/2018	09/18/2018			\$18,900.00
	09/21/2018	A00200378	WKCCD Custodian Revolving Ca	P0049288	09/20/2018	09/20/2018			\$500.00
		A00201773	American Association of Comm	P0049278	09/20/2018	09/20/2018			\$6,387.00
		A00303165	Van Dermyden Maddox Law Corp	P0049279	09/20/2018	09/20/2018			\$21,598.76
									-----
						TOTAL USER			\$48,106.48
TROMANDIA	09/28/2018	A00210285	Innovative Educators	P0049344	09/27/2018	09/28/2018			\$295.00
									-----
						TOTAL USER			\$295.00
TROWDEN	09/11/2018	A00200608	The Fort Preservation Societ	P0049093	08/31/2018	08/31/2018			\$435.00
	09/21/2018	A00200238	Department of Justice	P0049140	09/07/2018	09/07/2018			\$2,062.00
	09/24/2018	A00303325	Monster Government Solutions	P0049141	09/07/2018	09/07/2018			\$699.00
									-----
						TOTAL USER			\$3,196.00

**West Kern Community College District  
Board of Trustees Meeting  
October 10, 2018**

**Agenda Item 13.**

**A. Academic Employment**

**1. Reduced Workload Program**

Item	Name	Assignment	Step	Hourly Rate	Effective Date
a.	Jones, Diane	Initial Reduced Workload Agreement Application for Five Year Term Beginning 2019-20 Academic Year	N/A	--	8/19/19 - 05/20/20

**2. 2018 Fall Substitute Assignments**

Item	Name	Assignment	Step	Hourly Rate	Effective Date
a.	Galvan, Enemerio	Substitute for ART Courses	3	\$68.77	9/18/18 - 12/14/18
b.	Lively, Ashley Marie	Substitute for ART Courses	2	\$61.30	9/18/18 - 12/14/18

**3. 2018-19 Club Advisor Stipends**

Item	Name	Assignment	Step	Stipend	Effective Date
a.	Beasley, Michelle	Early Childhood Education	--	\$1,695.39	8/20/18 - 5/24/19
b.	Dyer, Geoffrey	Literary Magazine	--	\$1,695.39	8/20/18 - 5/24/19
c.	Getty, Shelley	CRU	--	\$1,695.39	8/20/18 - 5/24/19
d.	Golling, Leigh	Performing Arts	--	\$1,695.39	8/20/18 - 5/24/19
e.	May, James	STEM	--	\$1,695.39	8/20/18 - 5/24/19
f.	Mendoza, Tina	Veterans	--	\$1,695.39	8/20/18 - 5/24/19
g.	Oja, Michelle	Social Science Research Group	--	\$1,695.39	8/20/18 - 5/24/19
h.	Reynolds, David	Role-Playing Game	--	\$1,695.39	8/20/18 - 5/24/19

**4. 2018 Athletic Assignments**

Item	Name	Assignment	Step	Stipend	Effective Date
a.	DeVon, Sherman	Assistant Women's Basketball Coach	--	\$4,749.60	10/1/18 - 3/31/19

**5. 2018 Fall Adjunct Assignment**

Item	Name	Assignment	Step	Hourly Rate	Effective Date
a.	Hernandez, Isaias	Wellness Counselor	3	\$68.77	7/1/18 - 6/30/19

**West Kern Community College District  
Board of Trustees Meeting  
October 10, 2018**

**Agenda Item 13.**

**B. Classified Employment**

Item	Name	Position	% Assignment	Range/ Step	Salary	Term	Effective Date
<b>1. Administrative Services</b>							
a.	Aguirre, Manny	Driver	Temporary	10F	\$19.51	A/N	9/10/18 - 9/10/18
b.	Duran, Diana	Accounting Technician Working Out of Class Stipend	Temporary	From 20F- 22F	\$1.30	A/N	10/1/18 - 12/31/18
<b>2. Instruction</b>							
a.	Avina, Nicole	Integrated Technology Support Tech. Working out of Class Stipend In absence of D.E. Coord.	Temporary	From 30E to 40E	\$8.76	A/N	9/1/18 - 12/21/18
b.	Holt, Anna	Distance Education Aide I	Temporary	15A	\$17.30	A/N	9/24/18 - 12/21/18
c.	Medel, Angelica	Children's Center Assistant Teacher	Substitute	1A	\$12.24	A/N	9/01/18 - 6/30/19
d.	Rios, Debbie	TIL Secretary	Temporary	13A	\$16.46	A/N	10/01/18 - 10/31/18
e.	Tipton-Cash, Heather	Distance Education Aide I	Temporary	15B	\$18.16	A/N	9/19/18 - 9/30/18
f.	Tipton-Cash, Heather	Distance Education Aide I	47.5%	15B	\$18.16	12mo	10/01/18 - 6/30/19
<b>3. Superintendent/President</b>							
a.	Gustavo, Gonzalez	Network Administrator	100%	33D	\$31.23	12mo	9/20/18 - 6/30/19

**C. Resignations/Retirements**

Item	Name	Position	% Assignment	Range/ Step	Salary	Term	Effective Date
a.	Cook, Nichole	Admissions Technician	--	--	--	--	9/25/18
b.	Hinojosa, Guadalupe	Children's Center Assistant Teacher	--	--	--	--	9/07/18
c.	Reed, Billie	Children's Center Cook	--	--	--	--	12/31/18
d.	Saldana, Elizabeth	TPSID Accommodation Specialist	--	--	--	--	9/13/18
e.	Marcell, Jamia	TIL Transition Specialist	--	--	--	--	11/01/18

**WEST KERN COMMUNITY COLLEGE DISTRICT GENERAL FUND UNRESTRICTED  
 BUDGETED SOURCES OF FUNDS AT ACCOUNT LEVEL 1  
 REVENUE ACCOUNTS FISCAL YEAR 2018-2019  
 FOR THE MONTH ENDING SEPTEMBER 30, 2018**

Account Level	Account Level Description	Adopted Budget	Adjusted Budget	YTD Activity	Encumbrances	Balance
8600	State Revenues	17,053,137	17,053,137	4,048,552	0	13,004,585
8800	Local Revenues	10,556,357	10,556,357	1,495,759	0	9,060,598
<b>Summary</b>		<b>27,609,494</b>	<b>27,609,494</b>	<b>5,544,311</b>	<b>0</b>	<b>22,065,183</b>

**West Kern Community College District General Fund Unrestricted  
 Budgeted Sources of Funds at Account Level 1  
 Expenditure Accounts Fiscal Year 2018-19  
 For the Month Ending September 30, 2018**

Account Level	Account Level Description	Adopted Budget	Adjusted Budget	YTD Activity	Encumbrances	Balance
1000	Academic Salaries	9,122,990	9,122,990	1,636,917	0	7,486,073
2000	Classified & Other Nonacademic Sala	4,979,580	4,979,580	1,067,310	0	3,912,270
3000	Employee Benefits	6,831,238	6,831,238	1,522,591	407,328	4,901,318
4000	Supplies and Materials	464,396	464,396	71,244	115,498	277,654
5000	Other Operating Expenses & Services	4,697,220	4,697,220	1,057,428	1,424,425	2,215,367
6000	Capital Outlay	583,279	583,279	15,913	4,333	563,033
7000	Other Outgo	531,790	531,790	92,505	0	439,285
7200	Transfers	399,000	399,000	250,000	0	149,000
<b>Summary</b>		<b>27,609,493</b>	<b>27,609,493</b>	<b>5,713,908</b>	<b>1,951,585</b>	<b>19,944,000</b>



**Disbursement Register of Expenditures Greater than \$10,000  
For the Month of September 2018**

Check Number	Check Date	Vendor Name	Description	Net Amount
78038254	09/04/2018	AMS.NET	18-19 CISCO Network Maint & InfoCast Renewal	13,943.10
78038276	09/04/2018	IBM	IMB SPSS for 18-19	11,715.22
78038288	09/04/2018	Pearson Education	Textbooks	16,781.75
78038554	09/12/2018	Jamie Rebecca Smith	Consultant for Childcare Ctr	12,523.74
78038563	09/12/2018	Sysco Food Service of Ventura	food 179595635, 179589293, 179589294	10,395.89
78038646	09/19/2018	John Karwoski	John Karwoski - Open PO 18-19	10,920.00
78038658	09/19/2018	Michael Flooring Inc.	Flooring install - G-8 & Dental Hygiene	12,845.18
78038665	09/19/2018	P. G. & E.	PG&E - Open PO 18-19 - District	30,085.44
78038688	09/19/2018	Sysco Food Service of Ventura	food 179603950, 179610563	10,687.33
78038692	09/19/2018	Taft College Bookstore	TC Bookstore - PELL	89,053.09
78038716	09/19/2018	Westec	WESTEC - 18-19 Open PO for 300 FTES	89,643.75
78038722	09/24/2018	AP Architects	AP Architects - master planning - August	24,029.29
78038725	09/24/2018	Clear Blue Energy Corporation	Clear Blue Energy - Prop 39 - Pay App 1	10,589.34
78038740	09/24/2018	P. G. & E.	PG&E - Open PO 18-19 - District	28,696.68
78038760	09/25/2018	Amy Marie Cadena	REFUND - Standard	14,700.00
				<b>386,609.80</b>

**ASB 2018/19**  
**Balance Sheet**  
As of September 30, 2018

September 30, 2018

**ASSETS**

Current Assets

Checking/Savings

ASB Chevron 185,691.85

ASB Chevron - Savings 143.42

Total Checking/Savings 185,835.27

Total Current Assets 185,835.27

**TOTAL ASSETS** 185,835.27

**LIABILITIES & EQUITY**

Equity

Restricted Funds

Anime and Above 101.00

Art Club 834.00

ASB Athletics 43,974.74

ASB General - Operating 67,906.16

ASSE 385.43

Baseball Club 3,685.91

Best Buddies 3,619.23

Cougar Echo 773.50

CRU 730.32

**D.H. GENERAL**

D.H. CLASS OF 2019 825.00

D.H. SADHA 2,054.32

D.H. GENERAL - Other 0.00

Total D.H. GENERAL 2,879.32

ECE 1,069.59

Golf Club - Mens 1,391.80

Golf Club - Womens 2,620.67

Literary Club 1,101.53

NSLS Club 2,308.80

On Our Own 1,258.24

Performing Arts 3,191.62

Phi Theta Kappa 653.68

Roleplaying Game Club 336.22

Soccer Club - Mens 10,127.37

Soccer Club - Womens 2,486.67

Social Science/ Research 1,051.36

Softball Fund 1,753.10

Spectrum 1,873.04

STEM 2,053.59

TC Cares 609.00

**ASB 2018/19**  
**Balance Sheet**  
**As of September 30, 2018**

**September 30, 2018**

TIL Reunion	1,461.73
Uniform Replacement	18,641.70
Veterans Club	834.00
Women's Athletic Club	5,641.48
Women's Basketball Club	480.47
<b>Total Restricted Funds</b>	<b>185,835.27</b>
<b>Total Equity</b>	<b>185,835.27</b>
<b>TOTAL LIABILITIES &amp; EQUITY</b>	<b>185,835.27</b>

**COUNTY OF KERN**  
**ELECTRONIC RECORD OF DEPOSIT**  
 SEC.26900-26902 GOV.CODE

USER NAME  
 Mindy Jewell  
 SUBMIT DATE  
 Sep 06, 2018 10:31:27AM  
 PROCESS DATE  
 NOT PROCESSED AT  
 THIS TIME  
 EROD NO.  
 478969

DEPT NO.  
 0886

THE AUDITOR - CONTROLLER OF KERN COUNTY, HEREBY CERTIFIES THAT THE AMOUNT DUE  
 THE TREASURER OF SAID COUNTY FOR MONEYS COLLECTED BY WEST KERN COMMUNITY COLLEGE DIST-GENERAL  
 IN SETTLEMENT OF THE FOLLOWING ACCOUNTS IS THE SUM OF **\$2,600.61**

DESCRIPTION OF DEPOSIT	FUND NO.	DEPT NO.	REVENUE CODE	AMOUNT	FUND TOTAL
BOOKSTORE	84698	0886	5490	\$2,600.61	
					\$2,600.61

TOTAL DEPOSIT: **\$2,600.61**

**GENERAL DEPOSIT NOTES:**

**SITE OF DEPOSIT: BANK ACCOUNT DEPOSITED: General CASH: \$2,600.61 CHECKS: \$0.00 DIRECT DEPOSIT: \$0.00 CREDIT  
 CARD: \$0.00  
 NOTES: DEPOSIT #190030**

SECTION 26901 GOVERNMENT CODE  
 I HEREBY SWEAR THAT THIS IS A TRUE AND  
 CORRECT RECORD OF THE TOTAL AMOUNT  
 DUE THE KERN COUNTY TREASURER TO  
 AND INCLUDING:

**NOT PROCESSED**  
NOT SIGNED  
 AUDITOR'S AUTHORIZED SIGNATURE

**NOT PROCESSED**  
NOT SIGNED  
 TTC AUTHORIZED SIGNATURE

078 WEST KERN COMM. COLLEGE  
WKCCD DEPOSIT

DEPOSIT TRANSACTIONS  
Date last used from: 09/06/2018 To 09/06/2018  
Transaction Number from: 190030 To 190030  
Date entered from: 00/00/0000 To 99/99/9999

J96101 DC0100 L.00.01 09/06/18 PAG

APPROVED AND UNAPPROVED TRANSACTIONS

NUMBER	DATE	ENTERED	DESCRIPTION	-FUND-ORG-ACCT-PROGR-	AMOUNT
LN.	DI	DETAIL	DESCR		
190030	09/06/2018	09/06/2018	WKCCD DEPOSIT		
1.	78	BOOKSTORE SALES		31000-423-8841-69100	
				ENTERED BY: MDJB UNAPPROVED	2,600.61
				TOTAL AMOUNT	2,600.61
				DISTRICT TOTAL	2,600.61
				GRAND TOTAL	2,600.61

**COUNTY OF KERN**  
**ELECTRONIC RECORD OF DEPOSIT**  
 SEC.26900-26902 GOV.CODE

USER NAME  
**Mindy Jewell**  
 SUBMIT DATE  
**Sep 06, 2018 10:32:27AM**  
 PROCESS DATE  
**NOT PROCESSED AT THIS TIME**  
 DEPT NO. 0886  
 EROD NO. 478970

THE AUDITOR - CONTROLLER OF KERN COUNTY, HEREBY CERTIFIES THAT THE AMOUNT DUE THE TREASURER OF SAID COUNTY FOR MONEYS COLLECTED BY WEST KERN COMMUNITY COLLEGE DIST-GENERAL IN SETTLEMENT OF THE FOLLOWING ACCOUNTS IS THE SUM OF **\$61,479.75**

DESCRIPTION OF DEPOSIT	FUND NO.	DEPT NO.	REVENUE CODE	AMOUNT	FUND TOTAL
STUDENT RECEIPTS	84096	0886	5490	\$61,479.75	\$61,479.75

TOTAL DEPOSIT: **\$61,479.75**

**GENERAL DEPOSIT NOTES:**

**SITE OF DEPOSIT: BANK ACCOUNT DEPOSITED: General CASH: \$61,479.75 CHECKS: \$0.00 DIRECT DEPOSIT: \$0.00 CREDIT CARD: \$0.00 NOTES: DEPOSIT #190031**

SECTION 26901 GOVERNMENT CODE  
 I HEREBY SWEAR THAT THIS IS A TRUE AND CORRECT RECORD OF THE TOTAL AMOUNT DUE THE KERN COUNTY TREASURER TO AND INCLUDING:

**NOT PROCESSED**

NOT SIGNED  
 AUDITOR'S AUTHORIZED SIGNATURE

**NOT PROCESSED**

NOT SIGNED  
 TTC AUTHORIZED SIGNATURE

078 WEST KERN COMM. COLLEGE  
WKCCD DEPOSIT

DEPOSIT TRANSACTIONS  
Date last used from: 09/06/2018 To 09/06/2018  
Transaction Number from: 190031 To 190031  
Date entered from: 00/00/0000 To 99/99/9999

J96102 DC0100 L.00.01 09/06/18 PAG.

APPROVED AND UNAPPROVED TRANSACTIONS  
NUMBER DATE ENTERED DESCRIPTION -FUND-ORG-ACCT-PROGR- AMOUNT  
LN. DI DETAIL DESCR

---

190031	09/06/2018	09/06/2018	WKCCD DEPOSIT		ENTERED BY: MDJB	UNAPPROVED	61,479.75
1.	78		STUDENT RECEIPTS	11000-000-9161-00000			61,479.75
						TOTAL AMOUNT	61,479.75
						DISTRICT TOTAL	61,479.75
						GRAND TOTAL	61,479.75

**COUNTY OF KERN**  
**ELECTRONIC RECORD OF DEPOSIT**  
 SEC.26900-26902 GOV.CODE

USER NAME  
 Mindy Jewell  
 SUBMIT DATE  
 Sep 06, 2018 10:34:25AM  
 PROCESS DATE  
 NOT PROCESSED AT  
 THIS TIME  
 EROD NO.  
 478973

DEPT NO.  
 0886

THE AUDITOR - CONTROLLER OF KERN COUNTY, HEREBY CERTIFIES THAT THE AMOUNT DUE  
 THE TREASURER OF SAID COUNTY FOR MONEYS COLLECTED BY WEST KERN COMMUNITY COLLEGE DIST-GENERAL  
 IN SETTLEMENT OF THE FOLLOWING ACCOUNTS IS THE SUM OF **\$8,968.73**

DESCRIPTION OF DEPOSIT	FUND NO.	DEPT NO.	REVENUE CODE	AMOUNT	FUND TOTAL
GENERAL FUND	84096	0886	5490	\$42.75	\$42.75
RESTRICTED FUND	84097	0886	5490	\$6,020.75	\$6,020.75
CHILD DEVELOPMENT	84496	0886	5490	\$1,445.00	\$1,445.00
CAFETERIA	84699	0886	5490	\$1,460.23	\$1,460.23

TOTAL DEPOSIT: **\$8,968.73**

**GENERAL DEPOSIT NOTES:**

**SITE OF DEPOSIT: BANK ACCOUNT DEPOSITED: General CASH: \$8,968.73 CHECKS: \$0.00 DIRECT DEPOSIT: \$0.00 CREDIT  
 CARD: \$0.00  
 NOTES: DEPOSIT #190032**

SECTION 26901 GOVERNMENT CODE  
 I HEREBY SWEAR THAT THIS IS A TRUE AND  
 CORRECT RECORD OF THE TOTAL AMOUNT  
 DUE THE KERN COUNTY TREASURER TO  
 AND INCLUDING:

**NOT PROCESSED**

NOT SIGNED  
 AUDITOR'S AUTHORIZED SIGNATURE

**NOT PROCESSED**

NOT SIGNED  
 TTC AUTHORIZED SIGNATURE



378 WEST KERN COMM. COLLEGE  
WKCCD DEPOSIT

DEPOSIT TRANSACTIONS  
Date last used from: 09/06/2018 To 09/06/2018  
Transaction Number from: 190032 To 190032  
Date entered from: 00/00/0000 To 99/99/9999

J96103 DC0100 L.00.01 09/06/18 PAG:

APPROVED AND UNAPPROVED TRANSACTIONS

NUMBER	DATE	ENTERED	DESCRIPTION	-FUND-ORG-ACCT-PROGR-	AMOUNT
LN.	DI	DETAIL	DESCR		
190032	09/06/2018	09/06/2018	WKCCD DEPOSIT		
				ENTERED BY: MDJB UNAPPROVED	
1.	78	TESTING		11000-306-8892-49306	40.00
2.	78	RESTROOM DISPENSERS		11000-000-8876-00000	2.75
3.	78	DHS ADMIN		12602-309-8839-64992	5,646.75
4.	78	LIBRARY PROGRAMS		12201-203-8892-61200	374.00
5.	78	CAFETERIA SALES		32000-422-8841-69400	1,460.23
6.	78	CC GENERAL		33428-310-8621-69200	610.00
7.	78	CC STATE PRESCHOOL		33528-310-8621-69200	835.00
				TOTAL AMOUNT	8,968.73
				DISTRICT TOTAL	8,968.73
				GRAND TOTAL	8,968.73

**COUNTY OF KERN**  
**ELECTRONIC RECORD OF DEPOSIT**  
 SEC.26900-26902 GOV.CODE

USER NAME  
 Mindy Jewell  
 SUBMIT DATE  
 Sep 13, 2018 01:59:52PM  
 PROCESS DATE  
 NOT PROCESSED AT  
 THIS TIME  
 EROD NO.  
 479548

DEPT NO.  
 0886

THE AUDITOR - CONTROLLER OF KERN COUNTY, HEREBY CERTIFIES THAT THE AMOUNT DUE  
 THE TREASURER OF SAID COUNTY FOR MONEYS COLLECTED BY WEST KERN COMMUNITY COLLEGE DIST-GENERAL  
 IN SETTLEMENT OF THE FOLLOWING ACCOUNTS IS THE SUM OF **\$3,249.57**

DESCRIPTION OF DEPOSIT	FUND NO.	DEPT NO.	REVENUE CODE	AMOUNT	FUND TOTAL
BOOKSTORE	84698	0886	5490	\$3,249.57	\$3,249.57

TOTAL DEPOSIT: **\$3,249.57**

**GENERAL DEPOSIT NOTES:**

**SITE OF DEPOSIT: BANK ACCOUNT DEPOSITED: General CASH: \$3,249.57 CHECKS: \$0.00 DIRECT DEPOSIT: \$0.00 CREDIT  
 CARD: \$0.00  
 NOTES: DEPOSIT #190033**

SECTION 26901 GOVERNMENT CODE  
 I HEREBY SWEAR THAT THIS IS A TRUE AND  
 CORRECT RECORD OF THE TOTAL AMOUNT  
 DUE THE KERN COUNTY TREASURER TO  
 AND INCLUDING:

**NOT PROCESSED**

NOT SIGNED  
 AUDITOR'S AUTHORIZED SIGNATURE

**NOT PROCESSED**

NOT SIGNED  
 TTC AUTHORIZED SIGNATURE

078 WEST KERN COMM. COLLEGE  
 WKCCD DEPOSIT

DEPOSIT TRANSACTIONS  
 Date last used from: 09/13/2018 To 09/13/2018  
 Transaction Number from: 190033 To 190033  
 Date entered from: 00/00/0000 To 99/99/9999

J13455 DC0100 L.00.01 09/13/18 PAGE

APPROVED AND UNAPPROVED TRANSACTIONS										
NUMBER	DATE	ENTERED	DESCRIPTION	-FUND-ORG-ACCT-PROGR-						AMOUNT
LN.	DI	DETAIL	DESCR							
190033	09/13/2018	09/13/2018	WKCCD DEPOSIT	ENTERED BY: MDJB UNAPPROVED						3,249.57
1.	78	BOOKSTORE		31000-423-8841-69100						3,249.57
								TOTAL AMOUNT	3,249.57	
								DISTRICT TOTAL	3,249.57	
								GRAND TOTAL	3,249.57	

**COUNTY OF KERN**  
**ELECTRONIC RECORD OF DEPOSIT**  
SEC.26900-26902 GOV.CODE

USER NAME  
Mindy Jewell  
SUBMIT DATE  
Sep 13, 2018 02:01:02PM  
PROCESS DATE  
NOT PROCESSED AT  
THIS TIME  
DEPT NO. 0886  
EROD NO. 479549

THE AUDITOR - CONTROLLER OF KERN COUNTY, HEREBY CERTIFIES THAT THE AMOUNT DUE  
THE TREASURER OF SAID COUNTY FOR MONEYS COLLECTED BY WEST KERN COMMUNITY COLLEGE DIST-GENERAL  
IN SETTLEMENT OF THE FOLLOWING ACCOUNTS IS THE SUM OF \$3,169.00

DESCRIPTION OF DEPOSIT	FUND NO.	DEPT NO.	REVENUE CODE	AMOUNT	FUND TOTAL
STUDENT RECEIPTS	84086	0886	5490	\$3,169.00	\$3,169.00

TOTAL DEPOSIT: \$3,169.00

**GENERAL DEPOSIT NOTES:**

SITE OF DEPOSIT: BANK ACCOUNT DEPOSITED: General CASH: \$3,169.00 CHECKS: \$0.00 DIRECT DEPOSIT: \$0.00 CREDIT  
CARD: \$0.00  
NOTES: DEPOSIT #190034

SECTION 26901 GOVERNMENT CODE  
I HEREBY SWEAR THAT THIS IS A TRUE AND  
CORRECT RECORD OF THE TOTAL AMOUNT  
DUE THE KERN COUNTY TREASURER TO  
AND INCLUDING:

NOT PROCESSED

NOT SIGNED  
AUDITOR'S AUTHORIZED SIGNATURE

NOT PROCESSED

NOT SIGNED  
TTC AUTHORIZED SIGNATURE

378 WEST KERN COMM. COLLEGE  
WKCCD DEPOSIT

DEPOSIT TRANSACTIONS  
Date last used from: 09/13/2018 To 09/13/2018  
Transaction Number from: 190034 To 190034  
Date entered from: 00/00/0000 To 99/99/9999

J13456 DC0100 L.00.01 09/13/18 PAG

APPROVED AND UNAPPROVED TRANSACTIONS  
NUMBER DATE ENTERED DESCRIPTION -FUND-ORG-ACCT-PROGR- AMOUNT  
LN. DI DETAIL DESCR

---

190034	09/13/2018	09/13/2018	WKCCD DEPOSIT		ENTERED BY: MDJB	UNAPPROVED	
1.	78		STUDENT RECEIPTS	11000-000-9161-00000			3,169.00
					TOTAL AMOUNT		3,169.00
					DISTRICT TOTAL		3,169.00
					GRAND TOTAL		3,169.00

**COUNTY OF KERN**  
**ELECTRONIC RECORD OF DEPOSIT**  
 SEC.26900-26902 GOV.CODE

USER NAME  
 Mindy Jewell  
 SUBMIT DATE  
 Sep 13, 2018 02:02:25PM  
 PROCESS DATE  
 NOT PROCESSED AT  
 THIS TIME  
 DEPT NO.  
 0886  
 EROD NO.  
 479550

THE AUDITOR - CONTROLLER OF KERN COUNTY, HEREBY CERTIFIES THAT THE AMOUNT DUE  
 THE TREASURER OF SAID COUNTY FOR MONEYS COLLECTED BY WEST KERN COMMUNITY COLLEGE DIST-GENERAL  
 IN SETTLEMENT OF THE FOLLOWING ACCOUNTS IS THE SUM OF **\$251,829.08**

DESCRIPTION OF DEPOSIT	FUND NO.	DEPT NO.	REVENUE CODE	AMOUNT	FUND TOTAL
GENERAL FUND	84096	0886	5490	\$508.38	\$508.38
RESTRICTED FUND	84097	0886	5490	\$247,548.13	\$247,548.13
CHILD DEVELOPMENT	84496	0886	5490	\$1,700.00	\$1,700.00
CAFETERIA	84699	0886	5490	\$2,072.57	\$2,072.57

TOTAL DEPOSIT: **\$251,829.08**

**GENERAL DEPOSIT NOTES:**

**SITE OF DEPOSIT: BANK ACCOUNT DEPOSITED: General CASH: \$251,829.08 CHECKS: \$0.00 DIRECT DEPOSIT: \$0.00 CREDIT  
 CARD: \$0.00  
 NOTES: DEPOSIT #190035**

SECTION 26901 GOVERNMENT CODE  
 I HEREBY SWEAR THAT THIS IS A TRUE AND  
 CORRECT RECORD OF THE TOTAL AMOUNT  
 DUE THE KERN COUNTY TREASURER TO  
 AND INCLUDING:

**NOT PROCESSED**

NOT SIGNED  
 AUDITOR'S AUTHORIZED SIGNATURE

**NOT PROCESSED**

NOT SIGNED  
 TTC AUTHORIZED SIGNATURE

078 WEST KERN COMM. COLLEGE  
 WKCCD DEPOSIT

DEPOSIT TRANSACTIONS  
 Date last used from: 09/13/2018 To 09/13/2018  
 Transaction Number from: 190035 To 190035  
 Date entered from: 00/00/0000 To 99/99/9999

J13457 DC0100 L.00.01 09/13/18 PAG

APPROVED AND UNAPPROVED TRANSACTIONS

NUMBER	DATE	ENTERED	DESCRIPTION	-FUND-ORG-ACCT-PROGR-	AMOUNT
LN.	DI	DETAIL	DESCR		
190035	09/13/2018	09/13/2018	WKCCD DEPOSIT		
				ENTERED BY: MDJB	UNAPPROVED
1.	78	INSURANCE REIMBURSEMENTS		11000-412-8892-67300	475.70
2.	78	REIMBURSEMENT		11495-216-5710-61900	32.68
3.	78	FEDERAL WORK STUDY		12401-353-8153-64600	2,794.00
4.	78	FWS ADMIN ALLOWANCE		12401-353-8151-64600	139.00
5.	78	LIBRARY PROGRAMS		12201-203-8892-61200	313.00
6.	78	REIMBURSEMENT		12000-401-8892-67200	10.00
7.	78	REIMBURSEMENT		12561-223-8647-60103	1,434.27
8.	78	REIMBURSEMENT		12558-223-8647-63100	211,294.59
9.	78	REIMBURSEMENT		12644-223-8647-60103	15,000.00
10.	78	REIMBURSEMENT		12565-223-8646-09565	16,563.27
11.	78	CAFETERIA SALES		32000-422-8841-69400	2,072.57
12.	78	CC STIPEND		33000-310-8892-69200	1,700.00
				TOTAL AMOUNT	251,829.08
				DISTRICT TOTAL	251,829.08
				GRAND TOTAL	251,829.08

**COUNTY OF KERN**  
**ELECTRONIC RECORD OF DEPOSIT**  
 SEC.26900-26902 GOV.CODE

USER NAME  
 Mindy Jewell  
 SUBMIT DATE  
 Sep 20, 2018 01:52:11PM  
 PROCESS DATE  
 NOT PROCESSED AT  
 THIS TIME  
 EROD NO.  
 480136

DEPT NO.  
 0886

THE AUDITOR - CONTROLLER OF KERN COUNTY, HEREBY CERTIFIES THAT THE AMOUNT DUE  
 THE TREASURER OF SAID COUNTY FOR MONEYS COLLECTED BY WEST KERN COMMUNITY COLLEGE DIST-GENERAL  
 IN SETTLEMENT OF THE FOLLOWING ACCOUNTS IS THE SUM OF \$3,976.67

DESCRIPTION OF DEPOSIT	FUND NO.	DEPT NO.	REVENUE CODE	AMOUNT	FUND TOTAL
BOOKSTORE	84698	0886	5490	\$3,976.67	\$3,976.67

TOTAL DEPOSIT: \$3,976.67

**GENERAL DEPOSIT NOTES:**

SITE OF DEPOSIT: BANK ACCOUNT DEPOSITED: General CASH: \$3,976.67 CHECKS: \$0.00 DIRECT DEPOSIT: \$0.00 CREDIT  
 CARD: \$0.00  
 NOTES: DEPOSIT #190036

SECTION 26901 GOVERNMENT CODE  
 I HEREBY SWEAR THAT THIS IS A TRUE AND  
 CORRECT RECORD OF THE TOTAL AMOUNT  
 DUE THE KERN COUNTY TREASURER TO  
 AND INCLUDING:

NOT PROCESSED  
NOT SIGNED  
 AUDITOR'S AUTHORIZED SIGNATURE

NOT PROCESSED  
NOT SIGNED  
 TTC AUTHORIZED SIGNATURE



078 WEST KERN COMM. COLLEGE  
WKCCD DEPOSIT

DEPOSIT TRANSACTIONS  
Date last used from: 09/20/2018 To 09/20/2018  
Transaction Number from: 190036 To 190036  
Date entered from: 00/00/0000 To 99/99/9999

J17769 DC0100 L.00.01 09/20/18 PAG

APPROVED AND UNAPPROVED TRANSACTIONS

NUMBER	DATE	ENTERED	DESCRIPTION	-FUND-ORG-ACCT-PROGR-	AMOUNT
LN.	DI	DETAIL	DESCR		
190036	09/20/2018	09/20/2018	WKCCD DEPOSIT		
1.	78	BOOKSTORE SALES		31000-423-8841-69100	
				ENTERED BY: MDJB UNAPPROVED	3,976.67
				TOTAL AMOUNT	3,976.67
				DISTRICT TOTAL	3,976.67
				GRAND TOTAL	3,976.67

**COUNTY OF KERN**  
**ELECTRONIC RECORD OF DEPOSIT**  
 SEC.26900-26902 GOV.CODE

USER NAME  
 Mindy Jewell  
 SUBMIT DATE  
 Sep 20, 2018 01:53:15PM  
 PROCESS DATE  
 NOT PROCESSED AT  
 THIS TIME  
 EROD NO.  
 480137

DEPT NO.  
 0886

THE AUDITOR - CONTROLLER OF KERN COUNTY, HEREBY CERTIFIES THAT THE AMOUNT DUE  
 THE TREASURER OF SAID COUNTY FOR MONEYS COLLECTED BY WEST KERN COMMUNITY COLLEGE DIST-GENERAL  
 IN SETTLEMENT OF THE FOLLOWING ACCOUNTS IS THE SUM OF **\$30,222.16**

DESCRIPTION OF DEPOSIT	FUND NO.	DEPT NO.	REVENUE CODE	AMOUNT	FUND TOTAL
STUDENT RECEIPTS	84096	0886	5490	\$30,222.16	\$30,222.16

TOTAL DEPOSIT: **\$30,222.16**

**GENERAL DEPOSIT NOTES:**

**SITE OF DEPOSIT: BANK ACCOUNT DEPOSITED: General CASH: \$30,222.16 CHECKS: \$0.00 DIRECT DEPOSIT: \$0.00 CREDIT CARD: \$0.00 NOTES: DEPOSIT #190037**

SECTION 26901 GOVERNMENT CODE  
 I HEREBY SWEAR THAT THIS IS A TRUE AND  
 CORRECT RECORD OF THE TOTAL AMOUNT  
 DUE THE KERN COUNTY TREASURER TO  
 AND INCLUDING:

**NOT PROCESSED**

NOT SIGNED  
 AUDITOR'S AUTHORIZED SIGNATURE

**NOT PROCESSED**

NOT SIGNED  
 TTC AUTHORIZED SIGNATURE

078 WEST KERN COMM. COLLEGE  
WKCCD DEPOSIT

DEPOSIT TRANSACTIONS  
Date last used from: 09/20/2018 To 09/20/2018  
Transaction Number from: 190037 To 190037  
Date entered from: 00/00/0000 To 99/99/9999

J17770 DC0100 L.00.01 09/20/18 PAG1

APPROVED AND UNAPPROVED TRANSACTIONS

NUMBER	DATE	ENTERED	DESCRIPTION	-FUND-ORG-ACCT-PROGR-	AMOUNT
LN.	DI	DETAIL	DESCR		
190037	09/20/2018	09/20/2018	WKCCD DEPOSIT		
1.	78	STUDENT RECEIPTS		11000-000-9161-00000	
				ENTERED BY: MDJB UNAPPROVED	30,222.16
				TOTAL AMOUNT	30,222.16
				DISTRICT TOTAL	30,222.16
				GRAND TOTAL	30,222.16

**COUNTY OF KERN**  
**ELECTRONIC RECORD OF DEPOSIT**  
 SEC.26900-26902 GOV.CODE

USER NAME  
 Mindy Jewell  
 SUBMIT DATE  
 Sep 20, 2018 01:55:22PM  
 PROCESS DATE  
 NOT PROCESSED AT  
 THIS TIME  
 DEPT NO. 0886  
 EROD NO. 480138

THE AUDITOR - CONTROLLER OF KERN COUNTY, HEREBY CERTIFIES THAT THE AMOUNT DUE  
 THE TREASURER OF SAID COUNTY FOR MONEYS COLLECTED BY WEST KERN COMMUNITY COLLEGE DIST-GENERAL  
 IN SETTLEMENT OF THE FOLLOWING ACCOUNTS IS THE SUM OF \$227,236.15

DESCRIPTION OF DEPOSIT	FUND NO.	DEPT NO.	REVENUE CODE	AMOUNT	FUND TOTAL
GENERAL FUND	84096	0886	5490	\$48,858.35	\$48,858.35
RESTRICTED FUND	84097	0886	5490	\$161,988.57	\$161,988.57
CHILD DEVELOPMENT	84496	0886	5490	\$10,672.98	\$10,672.98
TIL	84697	0886	5490	\$3,572.78	\$3,572.78
CAFETERIA	84699	0886	5490	\$2,143.47	\$2,143.47

TOTAL DEPOSIT: \$227,236.15

**GENERAL DEPOSIT NOTES:**

SITE OF DEPOSIT: BANK ACCOUNT DEPOSITED: General CASH: \$227,236.15 CHECKS: \$0.00 DIRECT DEPOSIT: \$0.00 CREDIT  
 CARD: \$0.00  
 NOTES: DEPOSIT #190038

SECTION 26901 GOVERNMENT CODE  
 I HEREBY SWEAR THAT THIS IS A TRUE AND  
 CORRECT RECORD OF THE TOTAL AMOUNT  
 DUE THE KERN COUNTY TREASURER TO  
 AND INCLUDING:

**NOT PROCESSED**  
NOT SIGNED  
 AUDITOR'S AUTHORIZED SIGNATURE

**NOT PROCESSED**  
NOT SIGNED  
 TTC AUTHORIZED SIGNATURE

078 WEST KERN COMM. COLLEGE  
WKCCD DEPOSIT

DEPOSIT TRANSACTIONS  
Date last used from: 09/20/2018 To 09/20/2018  
Transaction Number from: 190038 To 190038  
Date entered from: 00/00/0000 To 99/99/9999

J17771 DC0100 L.00.01 09/20/18 PAG

APPROVED AND UNAPPROVED TRANSACTIONS

NUMBER	DATE	ENTERED	DESCRIPTION	-FUND-ORG-ACCT-PROGR-	AMOUNT
LN.	DI	DETAIL	DESCR		
190038	09/20/2018	09/20/2018	WKCCD DEPOSIT		
				ENTERED BY: MDJB UNAPPROVED	
1.	78	GED/HISET TESTING		11000-306-8892-49306	25.00
2.	78	REIMBURSEMENT		11000-000-9511-00000	245.00
3.	78	COTOP OFFSET ADJUSTMENT		11000-000-9161-00000	1.53
4.	78	TRANSCRIPT FEES		11000-301-8879-64900	586.82
5.	78	WESTEC ENROLLMENT		11450-204-8874-70990	48,000.00
6.	78	LIBRARY PROGRAMS		12201-203-8892-61200	266.00
7.	78	PELL		12000-353-8154-64600	161,722.57
8.	78	CAFETERIA SALES		32000-422-8841-69400	2,143.47
9.	78	CC CHILD CARE FOOD		33429-310-8621-69200	10,672.98
10.	78	TIL		39000-314-8699-64991	3,572.78
				TOTAL AMOUNT	227,236.15
				DISTRICT TOTAL	227,236.15
				GRAND TOTAL	227,236.15

**COUNTY OF KERN**  
**ELECTRONIC RECORD OF DEPOSIT**  
SEC.26900-26902 GOV.CODE

USER NAME  
Mindy Jewell  
SUBMIT DATE  
Sep 20, 2018 02:52:15PM  
PROCESS DATE  
**NOT PROCESSED AT THIS TIME**  
EROD NO.  
480154

DEPT NO.  
0886

THE AUDITOR - CONTROLLER OF KERN COUNTY, HEREBY CERTIFIES THAT THE AMOUNT DUE THE TREASURER OF SAID COUNTY FOR MONEYS COLLECTED BY WEST KERN COMMUNITY COLLEGE DIST-GENERAL IN SETTLEMENT OF THE FOLLOWING ACCOUNTS IS THE SUM OF **\$225,000.00**

DESCRIPTION OF DEPOSIT	FUND NO.	DEPT NO.	REVENUE CODE	AMOUNT	FUND TOTAL
COP FUND 43	84701	0886	5490	\$225,000.00	\$225,000.00

TOTAL DEPOSIT: **\$225,000.00**

**GENERAL DEPOSIT NOTES:**

**SITE OF DEPOSIT:** TTC **ACCOUNT DEPOSITED:** General **CASH:** \$0.00 **CHECKS:** \$0.00 **DIRECT DEPOSIT:** \$225,000.00 **CREDIT CARD:** \$0.00  
**NOTES:** DEPOSIT #190039

SECTION 26901 GOVERNMENT CODE  
I HEREBY SWEAR THAT THIS IS A TRUE AND CORRECT RECORD OF THE TOTAL AMOUNT DUE THE KERN COUNTY TREASURER TO AND INCLUDING:

**NOT PROCESSED**  
NOT SIGNED  
AUDITOR'S AUTHORIZED SIGNATURE

**NOT PROCESSED**  
NOT SIGNED  
TTC AUTHORIZED SIGNATURE

078 WEST KERN COMM. COLLEGE  
WKCCD DEPOSIT

DEPOSIT TRANSACTIONS  
Date last used from: 09/20/2018 To 09/20/2018  
Transaction Number from: 190039 To 190039  
Date entered from: 00/00/0000 To 99/99/9999

J17836 DC0100 L.00.01 09/20/18 PAGE

APPROVED AND UNAPPROVED TRANSACTIONS

NUMBER	DATE	ENTERED	DESCRIPTION	-FUND-ORG-ACCT-PROGR-	AMOUNT
LN.	DI	DETAIL	DESCR		
190039	09/20/2018	09/20/2018	WKCCD DEPOSIT		
1.	78	COP FUND		43000-000-8981-00000	
				ENTERED BY: MDJB UNAPPROVED	225,000.00
				TOTAL AMOUNT	225,000.00
				DISTRICT TOTAL	225,000.00
				GRAND TOTAL	225,000.00

**COUNTY OF KERN**  
**ELECTRONIC RECORD OF DEPOSIT**  
 SEC.26900-26902 GOV.CODE

USER NAME  
 Mindy Jewell  
 SUBMIT DATE  
 Sep 24, 2018 01:25:59PM  
 PROCESS DATE  
 NOT PROCESSED AT  
 THIS TIME  
 EROD NO.  
 480394

DEPT NO.  
 0886

THE AUDITOR - CONTROLLER OF KERN COUNTY, HEREBY CERTIFIES THAT THE AMOUNT DUE  
 THE TREASURER OF SAID COUNTY FOR MONEYS COLLECTED BY **WEST KERN COMMUNITY COLLEGE DIST-GENERAL**  
 IN SETTLEMENT OF THE FOLLOWING ACCOUNTS IS THE SUM OF **\$596,505.00**

DESCRIPTION OF DEPOSIT	FUND NO.	DEPT NO.	REVENUE CODE	AMOUNT	FUND TOTAL
PROP 30 APPORTIONMENT	84096	0886	5490	\$596,505.00	\$596,505.00

TOTAL DEPOSIT: **\$596,505.00**

**GENERAL DEPOSIT NOTES:**

**SITE OF DEPOSIT: TTC ACCOUNT DEPOSITED: General CASH: \$0.00 CHECKS: \$0.00 DIRECT DEPOSIT: \$596,505.00 CREDIT CARD: \$0.00**  
 NOTES: DEPOSIT #190040

SECTION 26901 GOVERNMENT CODE  
 I HEREBY SWEAR THAT THIS IS A TRUE AND  
 CORRECT RECORD OF THE TOTAL AMOUNT  
 DUE THE KERN COUNTY TREASURER TO  
 AND INCLUDING:

**NOT PROCESSED**

NOT SIGNED  
 AUDITOR'S AUTHORIZED SIGNATURE

**NOT PROCESSED**

NOT SIGNED  
 TTC AUTHORIZED SIGNATURE



7

078 WEST KERN COMM. COLLEGE  
WKCCD DEPOSIT

DEPOSIT TRANSACTIONS  
Date last used from: 09/24/2018 To 09/24/2018  
Transaction Number from: 190040 To 190040  
Date entered from: 00/00/0000 To 99/99/9999

J19277 DC0100 L.00.01 09/24/18 PAG

APPROVED AND UNAPPROVED TRANSACTIONS

NUMBER	DATE	ENTERED	DESCRIPTION	-FUND-ORG-ACCT-PROGR-	AMOUNT
LN.	DI	DETAIL	DESCR		
190040	09/24/2018	09/24/2018	WKCCD DEPOSIT		596,505.00
1.	78	PROP 30	APPORTIONMENT	11005-000-8616-00000	596,505.00
				ENTERED BY: MDJB UNAPPROVED	
				TOTAL AMOUNT	596,505.00
				DISTRICT TOTAL	596,505.00
				GRAND TOTAL	596,505.00

**COUNTY OF KERN**  
**ELECTRONIC RECORD OF DEPOSIT**  
SEC.26900-26902 GOV.CODE

USER NAME  
Mindy Jewell  
SUBMIT DATE  
Sep 26, 2018 02:50:22PM  
PROCESS DATE  
NOT PROCESSED AT  
THIS TIME  
EROD NO.  
480636

DEPT NO.  
0886

THE AUDITOR - CONTROLLER OF KERN COUNTY, HEREBY CERTIFIES THAT THE AMOUNT DUE  
THE TREASURER OF SAID COUNTY FOR MONEYS COLLECTED BY WEST KERN COMMUNITY COLLEGE DIST-GENERAL  
IN SETTLEMENT OF THE FOLLOWING ACCOUNTS IS THE SUM OF **\$225,000.00**

DESCRIPTION OF DEPOSIT	FUND NO.	DEPT NO.	REVENUE CODE	AMOUNT	FUND TOTAL
COP FUND 43	84701	0886	5490	\$225,000.00	\$225,000.00

TOTAL DEPOSIT: **\$225,000.00**

**GENERAL DEPOSIT NOTES:**

SITE OF DEPOSIT: TTC ACCOUNT DEPOSITED: General CASH: \$0.00 CHECKS: \$0.00 DIRECT DEPOSIT: \$225,000.00 CREDIT  
CARD: \$0.00  
NOTES: DEPOSIT #190041

SECTION 26901 GOVERNMENT CODE  
I HEREBY SWEAR THAT THIS IS A TRUE AND  
CORRECT RECORD OF THE TOTAL AMOUNT  
DUE THE KERN COUNTY TREASURER TO  
AND INCLUDING:

NOT PROCESSED

NOT SIGNED  
AUDITOR'S AUTHORIZED SIGNATURE

NOT PROCESSED

NOT SIGNED  
TTC AUTHORIZED SIGNATURE

378 WEST KERN COMM. COLLEGE  
WKCCD DEPOSIT

DEPOSIT TRANSACTIONS  
Date last used from: 09/26/2018 To 09/26/2018  
Transaction Number from: 190041 To 190041  
Date entered from: 00/00/0000 To 99/99/9999

J20496 DC0100 L.00.01 09/26/18 PAG

				APPROVED AND UNAPPROVED TRANSACTIONS		
NUMBER	DATE	ENTERED	DESCRIPTION	-FUND-ORG-ACCT-PROGR-		AMOUNT
LN.	DI	DETAIL	DESCR			
190041	09/26/2018	09/26/2018	WKCCD DEPOSIT		ENTERED BY: MDJB UNAPPROVED	
1.	78	COP FUND 43		43000-000-8981-00000		225,000.00
					TOTAL AMOUNT	225,000.00
					DISTRICT TOTAL	225,000.00
					GRAND TOTAL	225,000.00

**COUNTY OF KERN**  
**ELECTRONIC RECORD OF DEPOSIT**  
 SEC.26900-26902 GOV.CODE

USER NAME  
 Mindy Jewell  
 SUBMIT DATE  
 Sep 26, 2018 03:36:38PM

PROCESS DATE  
 NOT PROCESSED AT  
 THIS TIME

DEPT NO.  
 0886

EROD NO.  
 480648

THE AUDITOR - CONTROLLER OF KERN COUNTY, HEREBY CERTIFIES THAT THE AMOUNT DUE  
 THE TREASURER OF SAID COUNTY FOR MONEYS COLLECTED BY **WEST KERN COMMUNITY COLLEGE DIST-GENERAL**  
 IN SETTLEMENT OF THE FOLLOWING ACCOUNTS IS THE SUM OF **\$2,102,270.00**

DESCRIPTION OF DEPOSIT	FUND NO.	DEPT NO.	REVENUE CODE	AMOUNT	FUND TOTAL
SEPTEMBER SCHOOL APPORTIONMENT	84096	0886	5490	\$1,687,961.00	\$1,687,961.00

SEPTEMBER SCHOOL APPORTIONMENT	84097	0886	5490	\$414,309.00	\$414,309.00
--------------------------------	-------	------	------	--------------	--------------

TOTAL DEPOSIT: **\$2,102,270.00**

**GENERAL DEPOSIT NOTES:**

**SITE OF DEPOSIT: TTC ACCOUNT DEPOSITED: General CASH: \$0.00 CHECKS: \$0.00 DIRECT DEPOSIT: \$2,102,270.00 CREDIT CARD: \$0.00**  
 NOTES: DEPOSIT #190043

SECTION 26901 GOVERNMENT CODE  
 I HEREBY SWEAR THAT THIS IS A TRUE AND  
 CORRECT RECORD OF THE TOTAL AMOUNT  
 DUE THE KERN COUNTY TREASURER TO  
 AND INCLUDING:

**NOT PROCESSED**

NOT SIGNED  
 AUDITOR'S AUTHORIZED SIGNATURE

**NOT PROCESSED**

NOT SIGNED  
 TTC AUTHORIZED SIGNATURE

078 WEST KERN COMM. COLLEGE  
 WKCCD DEPOSIT

DEPOSIT TRANSACTIONS  
 Date last used from: 09/26/2018 To 09/26/2018  
 Transaction Number from: 190043 To 190043  
 Date entered from: 00/00/0000 To 99/99/9999

J20539 DC0100 L.00.01 09/26/18 PAG

APPROVED AND UNAPPROVED TRANSACTIONS

NUMBER	DATE	ENTERED	DESCRIPTION	-FUND-ORG-ACCT-PROGR-	AMOUNT
LN.	DI	DETAIL	DESCR		
190043	09/26/2018	09/26/2018	WKCCD DEPOSIT	ENTERED BY: MDJB UNAPPROVED	
1.	78	SEPTEMBER SCHOOL APPORTIONMENT	11000-000-8612-00000		1,675,065.00
2.	78	SEPTEMBER SCHOOL APPORTIONMENT	11006-201-8633-00000		12,896.00
3.	78	SEPTEMBER SCHOOL APPORTIONMENT	12551-353-8615-64600		5,750.00
4.	78	SEPTEMBER SCHOOL APPORTIONMENT	12551-353-8625-64600		20,076.00
5.	78	SEPTEMBER SCHOOL APPORTIONMENT	12000-303-8622-64300		42,510.00
6.	78	SEPTEMBER SCHOOL APPORTIONMENT	12000-305-8624-64301		4,660.00
7.	78	SEPTEMBER SCHOOL APPORTIONMENT	12000-311-8623-64200		31,001.00
8.	78	SEPTEMBER SCHOOL APPORTIONMENT	12600-309-8627-64992		18,706.00
9.	78	SEPTEMBER SCHOOL APPORTIONMENT	12000-319-8644-00000		196,752.00
10.	78	SEPTEMBER SCHOOL APPORTIONMENT	12050-431-8654-00000		825.00
11.	78	SEPTEMBER SCHOOL APPORTIONMENT	12060-113-8634-67801		824.00
12.	78	SEPTEMBER SCHOOL APPORTIONMENT	12569-353-8691-64600		5,638.00
13.	78	SEPTEMBER SCHOOL APPORTIONMENT	12558-223-8647-60103		20,371.00
14.	78	SEPTEMBER SCHOOL APPORTIONMENT	12603-125-8643-68900		67,196.00
TOTAL AMOUNT					2,102,270.00
DISTRICT TOTAL					2,102,270.00
GRAND TOTAL					2,102,270.00

**COUNTY OF KERN**  
**ELECTRONIC RECORD OF DEPOSIT**  
 SEC.26900-26902 GOV.CODE

USER NAME  
 Mindy Jewell  
 SUBMIT DATE  
 Sep 27, 2018 10:28:52AM  
 PROCESS DATE  
 NOT PROCESSED AT  
 THIS TIME  
 EROD NO.  
 480703

DEPT NO.  
 0886

THE AUDITOR - CONTROLLER OF KERN COUNTY, HEREBY CERTIFIES THAT THE AMOUNT DUE  
 THE TREASURER OF SAID COUNTY FOR MONEYS COLLECTED BY WEST KERN COMMUNITY COLLEGE DIST-GENERAL  
 IN SETTLEMENT OF THE FOLLOWING ACCOUNTS IS THE SUM OF **\$836.00**

DESCRIPTION OF DEPOSIT	FUND NO.	DEPT NO.	REVENUE CODE	AMOUNT	FUND TOTAL
CAL GRANT FUNDS	84097	0886	5490	\$836.00	\$836.00

TOTAL DEPOSIT: **\$836.00**

**GENERAL DEPOSIT NOTES:**

**SITE OF DEPOSIT: BANK ACCOUNT DEPOSITED: General CASH: \$836.00 CHECKS: \$0.00 DIRECT DEPOSIT: \$0.00 CREDIT CARD: \$0.00**  
 NOTES: DEPOSIT #190044

SECTION 26901 GOVERNMENT CODE  
 I HEREBY SWEAR THAT THIS IS A TRUE AND  
 CORRECT RECORD OF THE TOTAL AMOUNT  
 DUE THE KERN COUNTY TREASURER TO  
 AND INCLUDING:

**NOT PROCESSED**  
NOT SIGNED  
 AUDITOR'S AUTHORIZED SIGNATURE

**NOT PROCESSED**  
NOT SIGNED  
 TTC AUTHORIZED SIGNATURE

078 WEST KERN COMM. COLLEGE  
 WKCCD DEPOSIT

DEPOSIT TRANSACTIONS  
 Date last used from: 09/27/2018 To 09/27/2018  
 Transaction Number from: 190044 To 190044  
 Date entered from: 00/00/0000 To 99/99/9999

J20777 DC0100 L.00.01 09/27/18 PAG

APPROVED AND UNAPPROVED TRANSACTIONS

NUMBER	DATE	ENTERED	DESCRIPTION	-FUND-ORG-ACCT-PROGR-	AMOUNT
LN.	DI	DETAIL	DESCR		
190044	09/27/2018	09/27/2018	WKCCD DEPOSIT		836.00
1.	78	CAL GRANT FUNDS		12554-353-8641-64600	836.00
				ENTERED BY: MDJB UNAPPROVED	
				TOTAL AMOUNT	836.00
				DISTRICT TOTAL	836.00
				GRAND TOTAL	836.00

**COUNTY OF KERN**  
**ELECTRONIC RECORD OF DEPOSIT**  
 SEC.26900-26902 GOV.CODE

USER NAME  
 Mindy Jewell  
 SUBMIT DATE  
 Sep 27, 2018 10:30:38AM  
 PROCESS DATE  
 NOT PROCESSED AT  
 THIS TIME  
 DEPT NO.  
 0886  
 EROD NO.  
 480704

THE AUDITOR - CONTROLLER OF KERN COUNTY, HEREBY CERTIFIES THAT THE AMOUNT DUE  
 THE TREASURER OF SAID COUNTY FOR MONEYS COLLECTED BY WEST KERN COMMUNITY COLLEGE DIST-GENERAL  
 IN SETTLEMENT OF THE FOLLOWING ACCOUNTS IS THE SUM OF **\$292,060.00**

DESCRIPTION OF DEPOSIT	FUND NO.	DEPT NO.	REVENUE CODE	AMOUNT	FUND TOTAL
CAL GRANT FUNDS	84097	0886	5490	\$292,060.00	\$292,060.00

TOTAL DEPOSIT: **\$292,060.00**

**GENERAL DEPOSIT NOTES:**

**SITE OF DEPOSIT: BANK ACCOUNT DEPOSITED: General CASH: \$292,060.00 CHECKS: \$0.00 DIRECT DEPOSIT: \$0.00 CREDIT CARD: \$0.00**  
**NOTES: DEPOSIT #190045**

SECTION 26901 GOVERNMENT CODE  
 I HEREBY SWEAR THAT THIS IS A TRUE AND  
 CORRECT RECORD OF THE TOTAL AMOUNT  
 DUE THE KERN COUNTY TREASURER TO  
 AND INCLUDING:

**NOT PROCESSED**

NOT SIGNED  
 AUDITOR'S AUTHORIZED SIGNATURE

**NOT PROCESSED**

NOT SIGNED  
 TTC AUTHORIZED SIGNATURE



178 WEST KERN COMM. COLLEGE  
WKCCD DEPOSIT

DEPOSIT TRANSACTIONS  
Date last used from: 09/27/2018 To 09/27/2018  
Transaction Number from: 190045 To 190045  
Date entered from: 00/00/0000 To 99/99/9999

J20778 DC0100 L.00.01 09/27/18 PAG

APPROVED AND UNAPPROVED TRANSACTIONS

NUMBER	DATE	ENTERED	DESCRIPTION	-FUND-ORG-ACCT-PROGR-	AMOUNT
LN.	DI	DETAIL	DESCR		
190045	09/27/2018	09/27/2018	WKCCD DEPOSIT		
1.	78	CAL GRANT FUNDS		12554-353-8641-64600	
				ENTERED BY: MDJB UNAPPROVED	292,060.00
				TOTAL AMOUNT	292,060.00
				DISTRICT TOTAL	292,060.00
				GRAND TOTAL	292,060.00

**COUNTY OF KERN**  
**ELECTRONIC RECORD OF DEPOSIT**  
 SEC.26900-26902 GOV.CODE

USER NAME  
 Mindy Jewell  
 SUBMIT DATE  
 Sep 27, 2018 10:32:10AM  
 PROCESS DATE  
 NOT PROCESSED AT  
 THIS TIME  
 EROD NO.  
 480705

DEPT NO.  
 0886

THE AUDITOR - CONTROLLER OF KERN COUNTY, HEREBY CERTIFIES THAT THE AMOUNT DUE  
 THE TREASURER OF SAID COUNTY FOR MONEYS COLLECTED BY WEST KERN COMMUNITY COLLEGE DIST-GENERAL  
 IN SETTLEMENT OF THE FOLLOWING ACCOUNTS IS THE SUM OF **\$129,070.78**

DESCRIPTION OF DEPOSIT	FUND NO.	DEPT NO.	REVENUE CODE	AMOUNT	FUND TOTAL
CREDIT CARD STUDENT RECEIPTS	84096	0886	5490	\$129,070.78	
					\$129,070.78

TOTAL DEPOSIT: **\$129,070.78**

**GENERAL DEPOSIT NOTES:**

**SITE OF DEPOSIT: BANK ACCOUNT DEPOSITED: General CASH: \$129,070.78 CHECKS: \$0.00 DIRECT DEPOSIT: \$0.00 CREDIT CARD: \$0.00**  
 NOTES: DEPOSIT #190046

SECTION 26901 GOVERNMENT CODE  
 I HEREBY SWEAR THAT THIS IS A TRUE AND  
 CORRECT RECORD OF THE TOTAL AMOUNT  
 DUE THE KERN COUNTY TREASURER TO  
 AND INCLUDING:

**NOT PROCESSED**

NOT SIGNED  
 AUDITOR'S AUTHORIZED SIGNATURE

**NOT PROCESSED**

NOT SIGNED  
 TTC AUTHORIZED SIGNATURE

078 WEST KERN COMM. COLLEGE  
WKCCD DEPOSIT

DEPOSIT TRANSACTIONS  
Date last used from: 09/27/2018 To 09/27/2018  
Transaction Number from: 190046 To 190046  
Date entered from: 00/00/0000 To 99/99/9999

J20779 DC0100 L.00.01 09/27/18 PAG1

APPROVED AND UNAPPROVED TRANSACTIONS

NUMBER	DATE	ENTERED	DESCRIPTION	-FUND-ORG-ACCT-PROGR-	AMOUNT
LN.	DI	DETAIL	DESCR		
190046	09/27/2018	09/27/2018	WKCCD DEPOSIT		
1.	78	CREDIT CARD STUDENT RECEIPTS		11000-000-9161-00000	
				ENTERED BY: MDJB UNAPPROVED	129,070.78
				TOTAL AMOUNT	129,070.78
				DISTRICT TOTAL	129,070.78
				GRAND TOTAL	129,070.78

**COUNTY OF KERN**  
**ELECTRONIC RECORD OF DEPOSIT**  
 SEC.26900-26902 GOV.CODE

USER NAME  
 Mindy Jewell  
 SUBMIT DATE  
 Sep 27, 2018 10:33:52AM  
 PROCESS DATE  
 NOT PROCESSED AT  
 THIS TIME  
 EROD NO.  
 480706

DEPT NO.  
 0886

THE AUDITOR - CONTROLLER OF KERN COUNTY, HEREBY CERTIFIES THAT THE AMOUNT DUE  
 THE TREASURER OF SAID COUNTY FOR MONEYS COLLECTED BY WEST KERN COMMUNITY COLLEGE DIST-GENERAL  
 IN SETTLEMENT OF THE FOLLOWING ACCOUNTS IS THE SUM OF \$917.82

DESCRIPTION OF DEPOSIT	FUND NO.	DEPT NO.	REVENUE CODE	AMOUNT	FUND TOTAL
BOOKSTORE	84698	0886	5490	\$917.82	\$917.82

TOTAL DEPOSIT: \$917.82

**GENERAL DEPOSIT NOTES:**

SITE OF DEPOSIT: BANK ACCOUNT DEPOSITED: General CASH: \$917.82 CHECKS: \$0.00 DIRECT DEPOSIT: \$0.00 CREDIT CARD: \$0.00 NOTES: DEPOSIT #190047
--

SECTION 26901 GOVERNMENT CODE  
 I HEREBY SWEAR THAT THIS IS A TRUE AND  
 CORRECT RECORD OF THE TOTAL AMOUNT  
 DUE THE KERN COUNTY TREASURER TO  
 AND INCLUDING:

**NOT PROCESSED**  
NOT SIGNED  
 AUDITOR'S AUTHORIZED SIGNATURE

**NOT PROCESSED**  
NOT SIGNED  
 TTC AUTHORIZED SIGNATURE

WEST KERN COMM. COLLEGE  
WKCCD DEPOSIT

DEPOSIT TRANSACTIONS  
Date last used from: 09/27/2018 To 09/27/2018  
Transaction Number from: 190047 To 190047  
Date entered from: 00/00/0000 To 99/99/9999

J20780 DC0100 L.00.01 09/27/18 PAGE

APPROVED AND UNAPPROVED TRANSACTIONS

NUMBER	DATE	ENTERED	DESCRIPTION	-FUND-ORG-ACCT-PROGR-	AMOUNT
LN.	DI	DETAIL	DESCR		
190047	09/27/2018	09/27/2018	WKCCD DEPOSIT		917.82
1.	78	BOOKSTORE SALES		31000-423-8841-69100	917.82
					TOTAL AMOUNT
					917.82
					DISTRICT TOTAL
					917.82
					GRAND TOTAL
					917.82

ENTERED BY: MDJB UNAPPROVED

**COUNTY OF KERN**  
**ELECTRONIC RECORD OF DEPOSIT**  
SEC.26900-26902 GOV.CODE

USER NAME  
Mindy Jewell  
SUBMIT DATE  
Sep 27, 2018 10:34:55AM  
PROCESS DATE  
NOT PROCESSED AT  
THIS TIME  
EROD NO.  
480708

DEPT NO.  
0886

THE AUDITOR - CONTROLLER OF KERN COUNTY, HEREBY CERTIFIES THAT THE AMOUNT DUE  
THE TREASURER OF SAID COUNTY FOR MONEYS COLLECTED BY WEST KERN COMMUNITY COLLEGE DIST-GENERAL  
IN SETTLEMENT OF THE FOLLOWING ACCOUNTS IS THE SUM OF **\$19,760.00**

DESCRIPTION OF DEPOSIT	FUND NO.	DEPT NO.	REVENUE CODE	AMOUNT	FUND TOTAL
STUDENT RECEIPTS	84096	0886	5490	\$19,760.00	\$19,760.00

TOTAL DEPOSIT: **\$19,760.00**

**GENERAL DEPOSIT NOTES:**

SITE OF DEPOSIT: BANK ACCOUNT DEPOSITED: General CASH: \$19,760.00 CHECKS: \$0.00 DIRECT DEPOSIT: \$0.00 CREDIT  
CARD: \$0.00  
NOTES: DEPOSIT #190048

SECTION 26901 GOVERNMENT CODE  
I HEREBY SWEAR THAT THIS IS A TRUE AND  
CORRECT RECORD OF THE TOTAL AMOUNT  
DUE THE KERN COUNTY TREASURER TO  
AND INCLUDING:

NOT PROCESSED

NOT SIGNED \_\_\_\_\_  
AUDITOR'S AUTHORIZED SIGNATURE

NOT PROCESSED

NOT SIGNED \_\_\_\_\_  
TTC AUTHORIZED SIGNATURE

178 WEST KERN COMM. COLLEGE  
 WKCCD DEPOSIT

DEPOSIT TRANSACTIONS  
 Date last used from: 09/27/2018 To 09/27/2018  
 Transaction Number from: 190048 To 190048  
 Date entered from: 00/00/0000 To 99/99/9999

J20781 DC0100 L.00.01 09/27/18 PAG

APPROVED AND UNAPPROVED TRANSACTIONS

NUMBER	DATE	ENTERED	DESCRIPTION	-FUND-ORG-ACCT-PROGR-	AMOUNT
LN.	DI	DETAIL	DESCR		
190048	09/27/2018	09/27/2018	WKCCD DEPOSIT		
1.	78	STUDENT RECEIPTS		11000-000-9161-00000	19,760.00
				ENTERED BY: MDJB UNAPPROVED	
				TOTAL AMOUNT	19,760.00
				DISTRICT TOTAL	19,760.00
				GRAND TOTAL	19,760.00

**COUNTY OF KERN**  
**ELECTRONIC RECORD OF DEPOSIT**  
 SEC.26900-26902 GOV.CODE

USER NAME  
 Mindy Jewell  
 SUBMIT DATE  
 Sep 27, 2018 10:36:27AM  
 PROCESS DATE  
 NOT PROCESSED AT  
 THIS TIME  
 EROD NO.  
 480709

DEPT NO.  
 0886

THE AUDITOR - CONTROLLER OF KERN COUNTY, HEREBY CERTIFIES THAT THE AMOUNT DUE  
 THE TREASURER OF SAID COUNTY FOR MONEYS COLLECTED BY WEST KERN COMMUNITY COLLEGE DIST-GENERAL  
 IN SETTLEMENT OF THE FOLLOWING ACCOUNTS IS THE SUM OF **\$22,736.28**

DESCRIPTION OF DEPOSIT	FUND NO.	DEPT NO.	REVENUE CODE	AMOUNT	FUND TOTAL
GENERAL FUND	84096	0886	5490	\$9,324.56	\$9,324.56
RESTRICTED FUND	84097	0886	5490	\$11,311.71	\$11,311.71
CAFETERIA	84699	0886	5490	\$2,100.01	\$2,100.01

TOTAL DEPOSIT: **\$22,736.28**

**GENERAL DEPOSIT NOTES:**

**SITE OF DEPOSIT: BANK ACCOUNT DEPOSITED: General CASH: \$22,736.28 CHECKS: \$0.00 DIRECT DEPOSIT: \$0.00 CREDIT CARD: \$0.00 NOTES: DEPOSIT #190049**

SECTION 26901 GOVERNMENT CODE  
 I HEREBY SWEAR THAT THIS IS A TRUE AND  
 CORRECT RECORD OF THE TOTAL AMOUNT  
 DUE THE KERN COUNTY TREASURER TO  
 AND INCLUDING:

**NOT PROCESSED**  
NOT SIGNED  
 AUDITOR'S AUTHORIZED SIGNATURE

**NOT PROCESSED**  
NOT SIGNED  
 TTC AUTHORIZED SIGNATURE



178 WEST KERN COMM. COLLEGE  
 WKCCD DEPOSIT

DEPOSIT TRANSACTIONS  
 Date last used from: 09/27/2018 To 09/27/2018  
 Transaction Number from: 190049 To 190049  
 Date entered from: 00/00/0000 To 99/99/9999

J20782 DC0100 L.00.01 09/27/18 PAGE

APPROVED AND UNAPPROVED TRANSACTIONS

NUMBER	DATE	ENTERED	DESCRIPTION	-FUND-ORG-ACCT-PROGR-	AMOUNT
LN.	DI	DETAIL	DESCR		
190049	09/27/2018	09/27/2018	WKCCD DEPOSIT		
				ENTERED BY: MDJB	UNAPPROVED
1.	78	GED/HISET TESTING		11000-306-8892-49306	3,010.00
2.	78	INSURANCE REIMBURSEMENTS		11000-412-8892-67300	610.20
3.	78	REIMBURSEMENT		11000-352-5750-69612	2,214.90
4.	78	REIMBURSEMENT		11000-000-9511-00000	3,489.46
5.	78	FEDERAL WORK STUDY		12401-353-8153-64600	3,825.25
6.	78	FWS ADMIN ALLOWANCE		12401-353-8151-64600	190.75
7.	78	LIBRARY PROGRAMS		12201-203-8892-61200	297.00
8.	78	PELL		12000-353-8154-64600	1,278.00
9.	78	REIMBURSEMENT		12000-114-8892-70999	5,720.71
10.	78	CAFETERIA SALES		32000-422-8841-69400	2,100.01
				TOTAL AMOUNT	22,736.28
				DISTRICT TOTAL	22,736.28
				GRAND TOTAL	22,736.28

**COUNTY OF KERN**  
**ELECTRONIC RECORD OF DEPOSIT**  
 SEC.26900-26902 GOV.CODE

USER NAME  
 Mindy Jewell  
 SUBMIT DATE  
 Sep 28, 2018 03:03:59PM

PROCESS DATE  
 NOT PROCESSED AT  
 THIS TIME

DEPT NO.  
 0886

EROD NO.  
 480907

THE AUDITOR - CONTROLLER OF KERN COUNTY, HEREBY CERTIFIES THAT THE AMOUNT DUE  
 THE TREASURER OF SAID COUNTY FOR MONEYS COLLECTED BY WEST KERN COMMUNITY COLLEGE DIST-GENERAL  
 IN SETTLEMENT OF THE FOLLOWING ACCOUNTS IS THE SUM OF **\$134,206.39**

DESCRIPTION OF DEPOSIT	FUND NO.	DEPT NO.	REVENUE CODE	AMOUNT	FUND TOTAL
LOTTERY APPORTIONMENT	84096	0886	5490	\$64,675.72	\$64,675.72

LOTTERY APPORTIONMENT	84097	0886	5490	\$69,530.67	\$69,530.67
-----------------------	-------	------	------	-------------	-------------

TOTAL DEPOSIT: **\$134,206.39**

**GENERAL DEPOSIT NOTES:**

<b>SITE OF DEPOSIT:</b> TTC <b>ACCOUNT DEPOSITED:</b> General <b>CASH:</b> \$0.00 <b>CHECKS:</b> \$0.00 <b>DIRECT DEPOSIT:</b> \$134,206.39 <b>CREDIT CARD:</b> \$0.00 <b>NOTES:</b> DEPOSIT #190050
---

SECTION 26901 GOVERNMENT CODE  
 I HEREBY SWEAR THAT THIS IS A TRUE AND  
 CORRECT RECORD OF THE TOTAL AMOUNT  
 DUE THE KERN COUNTY TREASURER TO  
 AND INCLUDING:

**NOT PROCESSED**

NOT SIGNED  
 AUDITOR'S AUTHORIZED SIGNATURE

**NOT PROCESSED**

NOT SIGNED  
 TTC AUTHORIZED SIGNATURE

078 WEST KERN COMM. COLLEGE  
 WKCCD DEPOSIT

DEPOSIT TRANSACTIONS  
 Date last used from: 09/28/2018 To 09/28/2018  
 Transaction Number from: 190050 To 190050  
 Date entered from: 00/00/0000 To 99/99/9999

J21805 DC0100 L.00.01 09/28/18 PAG

APPROVED AND UNAPPROVED TRANSACTIONS

NUMBER	DATE	ENTERED	DESCRIPTION	-FUND-ORG-ACCT-PROGR-	AMOUNT
LN.	DI	DETAIL	DESCR		
190050	09/28/2018	09/28/2018	WKCCD DEPOSIT		
1.	78	LOTTERY APPORTIONMENT		11477-000-8681-00000	64,675.72
2.	78	LOTTERY APPORTIONMENT		12477-000-8681-00000	69,530.67
TOTAL AMOUNT					134,206.39
DISTRICT TOTAL					134,206.39
GRAND TOTAL					134,206.39

ENTERED BY: MDJB UNAPPROVED